

**LEGENDA**

	Bestaande situatie (bestaande / ontwerpen project Weesperhuis)		Inspectiepunt
	Nieuwe situatie		Waterafleiding/PMA-riem PVC 4250 mm
	Kadastrale grens		
	Geslotenlijn		
	Dwarsprofiel met nummer		
	Grondverkeuzingen talud met helling		
	Watergang		
	Duiker		
	Beuwing		
	Trafficork		
	Straatlicht		
	Witafleiding		

	Asfalt 100 mm		Asfalt 100 mm
	Asfalt 150 mm		Asfalt 150 mm
	Asfalt 200 mm		Asfalt 200 mm
	Asfalt 250 mm		Asfalt 250 mm
	Asfalt 300 mm		Asfalt 300 mm
	Asfalt 350 mm		Asfalt 350 mm
	Asfalt 400 mm		Asfalt 400 mm
	Asfalt 450 mm		Asfalt 450 mm
	Asfalt 500 mm		Asfalt 500 mm
	Asfalt 550 mm		Asfalt 550 mm
	Asfalt 600 mm		Asfalt 600 mm
	Asfalt 650 mm		Asfalt 650 mm
	Asfalt 700 mm		Asfalt 700 mm
	Asfalt 750 mm		Asfalt 750 mm
	Asfalt 800 mm		Asfalt 800 mm
	Asfalt 850 mm		Asfalt 850 mm
	Asfalt 900 mm		Asfalt 900 mm
	Asfalt 950 mm		Asfalt 950 mm
	Asfalt 1000 mm		Asfalt 1000 mm

**BIJBEHOORENDE TEKENINGEN**

- Dwarsprofieltekening 119626-13-2002-CON\_1-Dwarsprofieltekening
- Langsprofiel 119626-13-2003-CON\_1-Longsprofiel
- Labordingsplan 119626-13-2004-CON\_1-Labordingsplan
- Rijweginrichting 119626-13-2005-CON\_1-Rijweginrichting

**GEKOPPELDE XREFS**

- 119626-13-2002-CON\_1-Dwarsprofieltekening
- 119626-13-2003-CON\_1-Longsprofiel
- 119626-13-2004-CON\_1-Labordingsplan
- 119626-13-2005-CON\_1-Rijweginrichting

**OPMERKINGEN**

- Maten in meters tenzij anders aangegeven
- Hoogtemetingen in meters t.o.v. NAP
- Coördinaten in meters t.o.v. rijkswaarschetsaal
- Hoeken aangegeven in graden (DGP° stelsel)

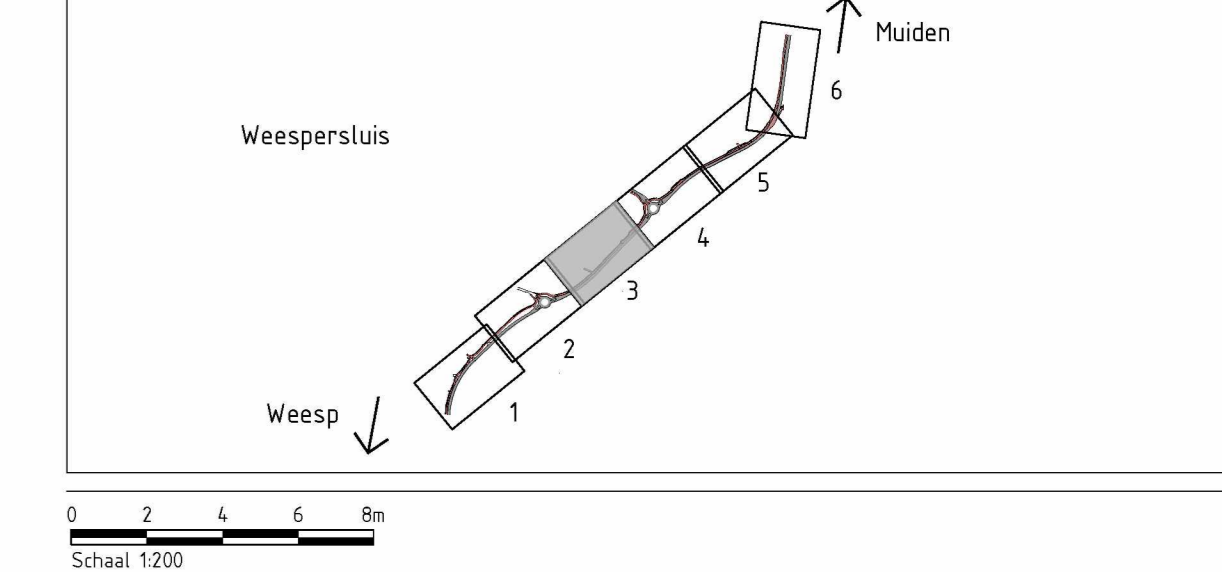

**Witteveen Bos**

Wijk: Gebied Datum: Omgeving

**CONCEPT**

Opdrachtgever: GEM Bloemendaalpolder

Project: Reconstructie Korte Muiderweg

Definitief ontwerp

Orderdeel: Nieuwe situatie

Status: Concept

Datum: 08-09-2023

schaal: 1:200

formaat: A0 (841 x 1470)

Projectcode: 119626

Tekeningnummer: 3001

Bladnummer: 3/6

Witteveen Bos Raadgevende Ingenieurs B.V. | Director: [Name]

Levensweg 1 | Postbus 211 | 1400 AC Zoveren | t: +31 (0)20 687 89 11 | www.witteveenbos.com | 0101 11 20 2023

SITUATIEOVERZICHT  
SCHAAL: 1:200





**LEGENDA**

	Bestaande situatie (bestaande of ontworpen project Weesperluis)		Inspectiepunt
	Nieuwe situatie		Waterleiding PMA-uitvoering PVC Ø250 mm
	Kadastrale grens		
	Geenbegrens		
	Dwarsprofiel met nummer		
	Grondverkeerslijnen (niet met helling)		
	Watergang		
	Duiker		
	Beuwtoring		
	Traffiekstok		
	Straatstok		
	Winkelvoorziening		

	Asfalt 100 mm		Asfalt 25 mm
	Asfalt 50 mm		Asfalt 10 mm
	Asfalt 20 mm		Asfalt 5 mm
	Asfalt 15 mm		Asfalt 10 mm
	Asfalt 10 mm		Asfalt 5 mm
	Asfalt 5 mm		Asfalt 2.5 mm
	Asfalt 2.5 mm		Asfalt 1.5 mm
	Asfalt 1.5 mm		Asfalt 0.75 mm
	Asfalt 0.75 mm		Asfalt 0.375 mm
	Asfalt 0.375 mm		Asfalt 0.1875 mm
	Asfalt 0.1875 mm		Asfalt 0.09375 mm
	Asfalt 0.09375 mm		Asfalt 0.046875 mm
	Asfalt 0.046875 mm		Asfalt 0.0234375 mm
	Asfalt 0.0234375 mm		Asfalt 0.01171875 mm
	Asfalt 0.01171875 mm		Asfalt 0.005859375 mm
	Asfalt 0.005859375 mm		Asfalt 0.0029296875 mm
	Asfalt 0.0029296875 mm		Asfalt 0.00146484375 mm
	Asfalt 0.00146484375 mm		Asfalt 0.000732421875 mm
	Asfalt 0.000732421875 mm		Asfalt 0.0003662109375 mm
	Asfalt 0.0003662109375 mm		Asfalt 0.00018310546875 mm
	Asfalt 0.00018310546875 mm		Asfalt 0.000091552734375 mm
	Asfalt 0.000091552734375 mm		Asfalt 0.0000457763671875 mm
	Asfalt 0.0000457763671875 mm		Asfalt 0.00002288818359375 mm
	Asfalt 0.00002288818359375 mm		Asfalt 0.000011444091796875 mm
	Asfalt 0.000011444091796875 mm		Asfalt 0.0000057220458984375 mm
	Asfalt 0.0000057220458984375 mm		Asfalt 0.00000286102294921875 mm
	Asfalt 0.00000286102294921875 mm		Asfalt 0.000001430511474609375 mm
	Asfalt 0.000001430511474609375 mm		Asfalt 0.0000007152557373046875 mm
	Asfalt 0.0000007152557373046875 mm		Asfalt 0.00000035762786865234375 mm
	Asfalt 0.00000035762786865234375 mm		Asfalt 0.000000178813934326171875 mm
	Asfalt 0.000000178813934326171875 mm		Asfalt 0.0000000894069671630859375 mm
	Asfalt 0.0000000894069671630859375 mm		Asfalt 0.00000004470348358154296875 mm
	Asfalt 0.00000004470348358154296875 mm		Asfalt 0.00000002235174179077146484375 mm
	Asfalt 0.00000002235174179077146484375 mm		Asfalt 0.000000011175870895385732421875 mm
	Asfalt 0.000000011175870895385732421875 mm		Asfalt 0.000000005587935447692866212109375 mm
	Asfalt 0.000000005587935447692866212109375 mm		Asfalt 0.0000000027939677238464331060546875 mm
	Asfalt 0.0000000027939677238464331060546875 mm		Asfalt 0.000000001396983861923216553030296875 mm
	Asfalt 0.000000001396983861923216553030296875 mm		Asfalt 0.0000000006984919309616277765151484375 mm
	Asfalt 0.0000000006984919309616277765151484375 mm		Asfalt 0.0000000003492459654808138887825742421875 mm
	Asfalt 0.0000000003492459654808138887825742421875 mm		Asfalt 0.00000000017462298274040694444126212109375 mm
	Asfalt 0.00000000017462298274040694444126212109375 mm		Asfalt 0.000000000087311491370203472220631060546875 mm
	Asfalt 0.000000000087311491370203472220631060546875 mm		Asfalt 0.0000000000436557456851017111031575296875 mm
	Asfalt 0.0000000000436557456851017111031575296875 mm		Asfalt 0.00000000002182787284255085555152646484375 mm
	Asfalt 0.00000000002182787284255085555152646484375 mm		Asfalt 0.0000000000109139364212754277762732421875 mm
	Asfalt 0.0000000000109139364212754277762732421875 mm		Asfalt 0.0000000000054569682106377138636366212109375 mm
	Asfalt 0.0000000000054569682106377138636366212109375 mm		Asfalt 0.00000000000272848410531885693181831060546875 mm
	Asfalt 0.00000000000272848410531885693181831060546875 mm		Asfalt 0.000000000001364242052659446590909152646484375 mm
	Asfalt 0.000000000001364242052659446590909152646484375 mm		Asfalt 0.000000000000682121026329723295454575296875 mm
	Asfalt 0.000000000000682121026329723295454575296875 mm		Asfalt 0.00000000000034106051316486164772732421875 mm
	Asfalt 0.00000000000034106051316486164772732421875 mm		Asfalt 0.00000000000017053025658243236386366212109375 mm
	Asfalt 0.00000000000017053025658243236386366212109375 mm		Asfalt 0.000000000000085265128291218191931060546875 mm
	Asfalt 0.000000000000085265128291218191931060546875 mm		Asfalt 0.00000000000004263256414590909152646484375 mm
	Asfalt 0.00000000000004263256414590909152646484375 mm		Asfalt 0.00000000000002131628207295454575296875 mm
	Asfalt 0.00000000000002131628207295454575296875 mm		Asfalt 0.0000000000000106581410364772732421875 mm
	Asfalt 0.0000000000000106581410364772732421875 mm		Asfalt 0.000000000000005329070518191931060546875 mm
	Asfalt 0.000000000000005329070518191931060546875 mm		Asfalt 0.0000000000000026645352590909152646484375 mm
	Asfalt 0.0000000000000026645352590909152646484375 mm		Asfalt 0.0000000000000013322676295454575296875 mm
	Asfalt 0.0000000000000013322676295454575296875 mm		Asfalt 0.000000000000000666133814772732421875 mm
	Asfalt 0.000000000000000666133814772732421875 mm		Asfalt 0.000000000000000333066907295454575296875 mm
	Asfalt 0.000000000000000333066907295454575296875 mm		Asfalt 0.00000000000000016653345364772732421875 mm
	Asfalt 0.00000000000000016653345364772732421875 mm		Asfalt 0.0000000000000000832667268236386366212109375 mm
	Asfalt 0.0000000000000000832667268236386366212109375 mm		Asfalt 0.0000000000000000416333634118191931060546875 mm
	Asfalt 0.0000000000000000416333634118191931060546875 mm		Asfalt 0.00000000000000002081668170590909152646484375 mm
	Asfalt 0.00000000000000002081668170590909152646484375 mm		Asfalt 0.00000000000000001040834085295454575296875 mm
	Asfalt 0.00000000000000001040834085295454575296875 mm		Asfalt 0.0000000000000000052041704264772732421875 mm
	Asfalt 0.0000000000000000052041704264772732421875 mm		Asfalt 0.00000000000000000260208521318191931060546875 mm
	Asfalt 0.00000000000000000260208521318191931060546875 mm		Asfalt 0.000000000000000001301042606590909152646484375 mm
	Asfalt 0.000000000000000001301042606590909152646484375 mm		Asfalt 0.000000000000000000650521303295454575296875 mm
	Asfalt 0.000000000000000000650521303295454575296875 mm		Asfalt 0.00000000000000000032526065164772732421875 mm



**LEGENDA**

	Bestaande situatie leiding / afwerpen project Weesperbus		Inspectiepunt
	Nieuwe situatie		Inspectiepunt
	Kadastrale grens		Inspectiepunt
	Gewasfregans		Inspectiepunt
	Duwersprofiel met nummer		Inspectiepunt
	Grondwerkzaamheden tabel met helling		Inspectiepunt
	Watergang		Inspectiepunt
	Duiker		Inspectiepunt
	Reiniging		Inspectiepunt
	Troostlaag		Inspectiepunt
	Straatvlak		Inspectiepunt
	Maatvoering		Inspectiepunt
	Afval: afval 10 mm		Inspectiepunt
	Afval: afval 20 mm		Inspectiepunt
	Afval: afval 30 mm		Inspectiepunt
	Afval: afval 40 mm		Inspectiepunt
	Afval: afval 50 mm		Inspectiepunt
	Afval: afval 60 mm		Inspectiepunt
	Afval: afval 70 mm		Inspectiepunt
	Afval: afval 80 mm		Inspectiepunt
	Afval: afval 90 mm		Inspectiepunt
	Afval: afval 100 mm		Inspectiepunt
	Afval: afval 120 mm		Inspectiepunt
	Afval: afval 150 mm		Inspectiepunt
	Afval: afval 200 mm		Inspectiepunt
	Afval: afval 250 mm		Inspectiepunt
	Afval: afval 300 mm		Inspectiepunt
	Afval: afval 400 mm		Inspectiepunt
	Afval: afval 500 mm		Inspectiepunt
	Afval: afval 600 mm		Inspectiepunt
	Afval: afval 800 mm		Inspectiepunt
	Afval: afval 1000 mm		Inspectiepunt
	Afval: afval 1200 mm		Inspectiepunt
	Afval: afval 1500 mm		Inspectiepunt
	Afval: afval 2000 mm		Inspectiepunt
	Afval: afval 2500 mm		Inspectiepunt
	Afval: afval 3000 mm		Inspectiepunt
	Afval: afval 4000 mm		Inspectiepunt
	Afval: afval 5000 mm		Inspectiepunt
	Afval: afval 6000 mm		Inspectiepunt
	Afval: afval 8000 mm		Inspectiepunt
	Afval: afval 10000 mm		Inspectiepunt

**BUREAUDE TEKENINGEN**

- Dwarsprofieltekening 119626-13-3002-CO1\_1-Dwarsprofieltekening
- Lengteprofielen 119626-13-3003-CO1\_1-Lengteprofielen
- Belegingsplan 119626-13-3004-CO1\_1-Belegingsplan
- Rigurvektekening 119626-13-3005-CO1\_1-Rigurvektekening

**GEKOPPELDE XREFS**

- 119626-13-3002-CO1\_1-Dwarsprofieltekening
- 119626-13-3003-CO1\_1-Lengteprofielen
- 119626-13-3004-CO1\_1-Belegingsplan
- 119626-13-3005-CO1\_1-Rigurvektekening
- 119626-13-3006-CO1\_1-Belegingsplan
- 119626-13-3007-CO1\_1-Belegingsplan
- 119626-13-3008-CO1\_1-Belegingsplan
- 119626-13-3009-CO1\_1-Belegingsplan
- 119626-13-3010-CO1\_1-Belegingsplan
- 119626-13-3011-CO1\_1-Belegingsplan
- 119626-13-3012-CO1\_1-Belegingsplan
- 119626-13-3013-CO1\_1-Belegingsplan
- 119626-13-3014-CO1\_1-Belegingsplan
- 119626-13-3015-CO1\_1-Belegingsplan
- 119626-13-3016-CO1\_1-Belegingsplan
- 119626-13-3017-CO1\_1-Belegingsplan
- 119626-13-3018-CO1\_1-Belegingsplan
- 119626-13-3019-CO1\_1-Belegingsplan
- 119626-13-3020-CO1\_1-Belegingsplan
- 119626-13-3021-CO1\_1-Belegingsplan
- 119626-13-3022-CO1\_1-Belegingsplan
- 119626-13-3023-CO1\_1-Belegingsplan
- 119626-13-3024-CO1\_1-Belegingsplan
- 119626-13-3025-CO1\_1-Belegingsplan
- 119626-13-3026-CO1\_1-Belegingsplan
- 119626-13-3027-CO1\_1-Belegingsplan
- 119626-13-3028-CO1\_1-Belegingsplan
- 119626-13-3029-CO1\_1-Belegingsplan
- 119626-13-3030-CO1\_1-Belegingsplan
- 119626-13-3031-CO1\_1-Belegingsplan
- 119626-13-3032-CO1\_1-Belegingsplan
- 119626-13-3033-CO1\_1-Belegingsplan
- 119626-13-3034-CO1\_1-Belegingsplan
- 119626-13-3035-CO1\_1-Belegingsplan
- 119626-13-3036-CO1\_1-Belegingsplan
- 119626-13-3037-CO1\_1-Belegingsplan
- 119626-13-3038-CO1\_1-Belegingsplan
- 119626-13-3039-CO1\_1-Belegingsplan
- 119626-13-3040-CO1\_1-Belegingsplan
- 119626-13-3041-CO1\_1-Belegingsplan
- 119626-13-3042-CO1\_1-Belegingsplan
- 119626-13-3043-CO1\_1-Belegingsplan
- 119626-13-3044-CO1\_1-Belegingsplan
- 119626-13-3045-CO1\_1-Belegingsplan
- 119626-13-3046-CO1\_1-Belegingsplan
- 119626-13-3047-CO1\_1-Belegingsplan
- 119626-13-3048-CO1\_1-Belegingsplan
- 119626-13-3049-CO1\_1-Belegingsplan
- 119626-13-3050-CO1\_1-Belegingsplan
- 119626-13-3051-CO1\_1-Belegingsplan
- 119626-13-3052-CO1\_1-Belegingsplan
- 119626-13-3053-CO1\_1-Belegingsplan
- 119626-13-3054-CO1\_1-Belegingsplan
- 119626-13-3055-CO1\_1-Belegingsplan
- 119626-13-3056-CO1\_1-Belegingsplan
- 119626-13-3057-CO1\_1-Belegingsplan
- 119626-13-3058-CO1\_1-Belegingsplan
- 119626-13-3059-CO1\_1-Belegingsplan
- 119626-13-3060-CO1\_1-Belegingsplan
- 119626-13-3061-CO1\_1-Belegingsplan
- 119626-13-3062-CO1\_1-Belegingsplan
- 119626-13-3063-CO1\_1-Belegingsplan
- 119626-13-3064-CO1\_1-Belegingsplan
- 119626-13-3065-CO1\_1-Belegingsplan
- 119626-13-3066-CO1\_1-Belegingsplan
- 119626-13-3067-CO1\_1-Belegingsplan
- 119626-13-3068-CO1\_1-Belegingsplan
- 119626-13-3069-CO1\_1-Belegingsplan
- 119626-13-3070-CO1\_1-Belegingsplan
- 119626-13-3071-CO1\_1-Belegingsplan
- 119626-13-3072-CO1\_1-Belegingsplan
- 119626-13-3073-CO1\_1-Belegingsplan
- 119626-13-3074-CO1\_1-Belegingsplan
- 119626-13-3075-CO1\_1-Belegingsplan
- 119626-13-3076-CO1\_1-Belegingsplan
- 119626-13-3077-CO1\_1-Belegingsplan
- 119626-13-3078-CO1\_1-Belegingsplan
- 119626-13-3079-CO1\_1-Belegingsplan
- 119626-13-3080-CO1\_1-Belegingsplan
- 119626-13-3081-CO1\_1-Belegingsplan
- 119626-13-3082-CO1\_1-Belegingsplan
- 119626-13-3083-CO1\_1-Belegingsplan
- 119626-13-3084-CO1\_1-Belegingsplan
- 119626-13-3085-CO1\_1-Belegingsplan
- 119626-13-3086-CO1\_1-Belegingsplan
- 119626-13-3087-CO1\_1-Belegingsplan
- 119626-13-3088-CO1\_1-Belegingsplan
- 119626-13-3089-CO1\_1-Belegingsplan
- 119626-13-3090-CO1\_1-Belegingsplan
- 119626-13-3091-CO1\_1-Belegingsplan
- 119626-13-3092-CO1\_1-Belegingsplan
- 119626-13-3093-CO1\_1-Belegingsplan
- 119626-13-3094-CO1\_1-Belegingsplan
- 119626-13-3095-CO1\_1-Belegingsplan
- 119626-13-3096-CO1\_1-Belegingsplan
- 119626-13-3097-CO1\_1-Belegingsplan
- 119626-13-3098-CO1\_1-Belegingsplan
- 119626-13-3099-CO1\_1-Belegingsplan
- 119626-13-3100-CO1\_1-Belegingsplan

**OPMERKINGEN**

- Haken in meters tenzij anders aangegeven
- Hoogteafwijking in meters t.o.v. NAP
- Coördinaten in meters t.o.v. Rijksdriehoekstelsel
- Hoeken aangegeven in graden (360° stelsel)

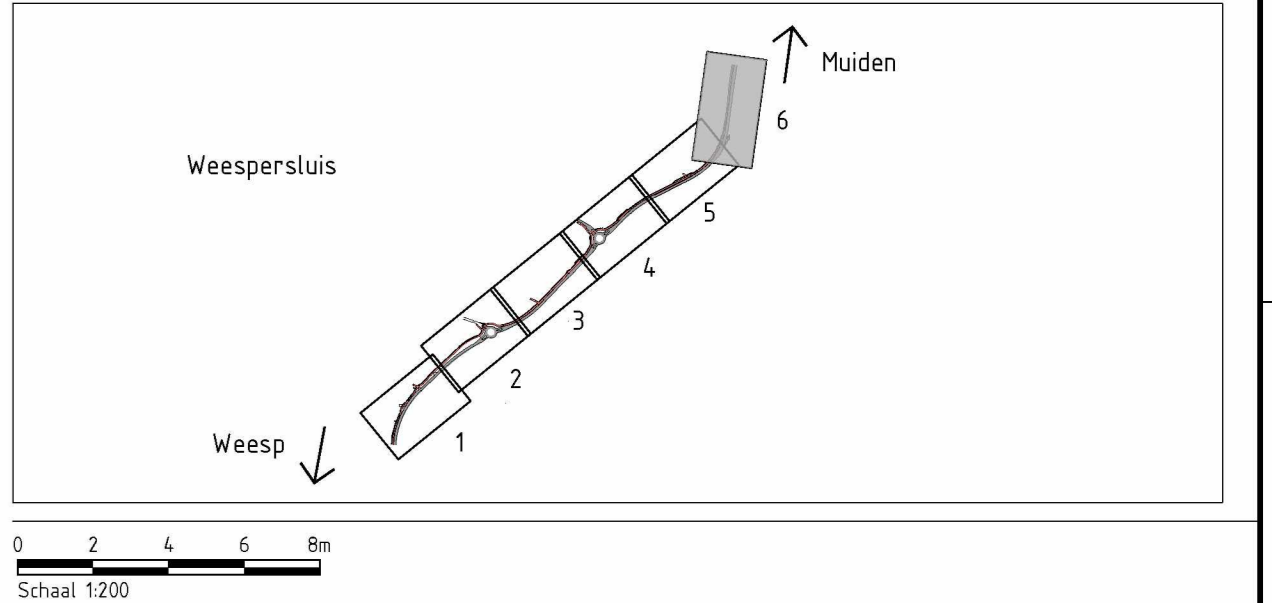

**Witteveen+Bos**

**CONCEPT**

**GEM Bloemendaalpolder**  
 Reconstructie Korte Muiderweg  
 Definitief ontwerp  
 Nieuwe situatie

Stuvia	Concept	Gepland	08-09-2023
Datum	08-09-2023	Gepland	08-09-2023
Uitsluit	AD (841 x 1680)	Projectcode	119626
Uitsluit	AD (841 x 1680)	Tekentruimte	3001
Uitsluit	AD (841 x 1680)	Bladnummer	6/6

Witteveen+Bos Realisatie Ingenieurs B.V. | Deventer  
 Looiseweg 8 | Postbus 221 | 7400 AC Deventer | t +31 (0)570 80 7111 | www.witteveenbos.com | KvK 08007191