

## Memo

**Bestemd voor:** dhr. 5.1, 2, e 5.1, 2, e, Lister Buildings, 's-Hertogenbosch  
**Betreft:** Toetrapport - OV - OLO-8325147  
**Opgesteld door:** ir. 5.1, 2, e  
**Kopie aan:** ir. 5.1, 2, e, ir. 5.1, 2, e

Datum: 22 februari 2024

Project: Koffiefabriek, Joan Muyskenweg  
19, Amsterdam

Betreft: Toetrapport - OV - OLO-8325147

Ref.: M-321-139-DO-01

### Inleiding / leeswijzer

In dit memo wordt een reactie gegeven op de benodigde aanvullingen / vragen uit het toetsrapport (toetsnummer 0) van de omgevingsdienst voor het project: "De Koffiefabriek te Amsterdam", zie bijlage 4. Voor de reacties op de verschillende vragen en opmerkingen wordt de nummering uit het toetsrapport aangehouden. Onderhavige reactie moet samen worden gelezen met de overige indieningstukken van het project, waaronder het constructieve uitgangspuntenrapport: R-321139-DO-101a. In aanvulling op de originele indiening stukken zijn enkele bijlagen geproduceerd waarvan in de onderstaande antwoorden/reacties verwezen wordt. Die bijlages zijn toegevoegd aan dit document.

### 1 Algemeen Hoofdpzset

#### 1.1 Gewichts- en stabiliteitsberekeningen

- Deze berekeningen behoren tot de TO-fase en worden later aangeleverd.

#### 1.2 Belastingen, belastingcombinaties, schematisatie

##### Stootbelastingen

- Alle kolommen die onderdeel zijn van de parkeergarage, zoals aangegeven in paragraaf 2.4 van het uitgangspunten rapport worden ontworpen op een stootbelasting conform NEN-EN 1991-1-7 (+ NB).
- De ondersteunende kolommen van de onderbouw van het woongebouw aangrenzend aan de parkeergarage op as C worden ontworpen op een stootbelasting.
- De overige kolommen van het woongebouw aangrenzend aan de parkeergarage op de assen 2a en 15b worden niet ontworpen op een stootbelasting. Voor die kolommen staat een kalkzandsteenwand, hierdoor zijn de kolommen beschermd van voertuigen en is een te rekenen stootbelasting niet nodig.
- Voor de kolommen aan de kanaalzijde op as A, is de afstand tot het hart van de rijbaan 9 meter. Vanaf 10 meter afstand hoeft geen stootbelasting gerekend te worden. Omdat de rijbaan een weg is die geen doorgaande weg betreft en enkel voor bestemmingsverkeer is, gaan wij uit van een stootbelasting gelijk aan die van een binnenplaats, hierdoor rekenen we met 100 kN.
- De kolom bij de entree van de parkeergarage (op kruising assen A-12), hoeft niet te worden ontworpen op een stootbelasting ten gevolge van een vrachtwagen want de parkeergarage is enkel toegankelijk voor personenauto's, hierdoor kan daar ook geen vrachtwagen komen om te lossen. Deze kolom wordt wel op 100 kN stootbelasting uit personen auto's gerekend.
- Voor een overzicht van de kolommen die worden berekend op de stootbelasting zie de afbeelding op de volgende pagina.

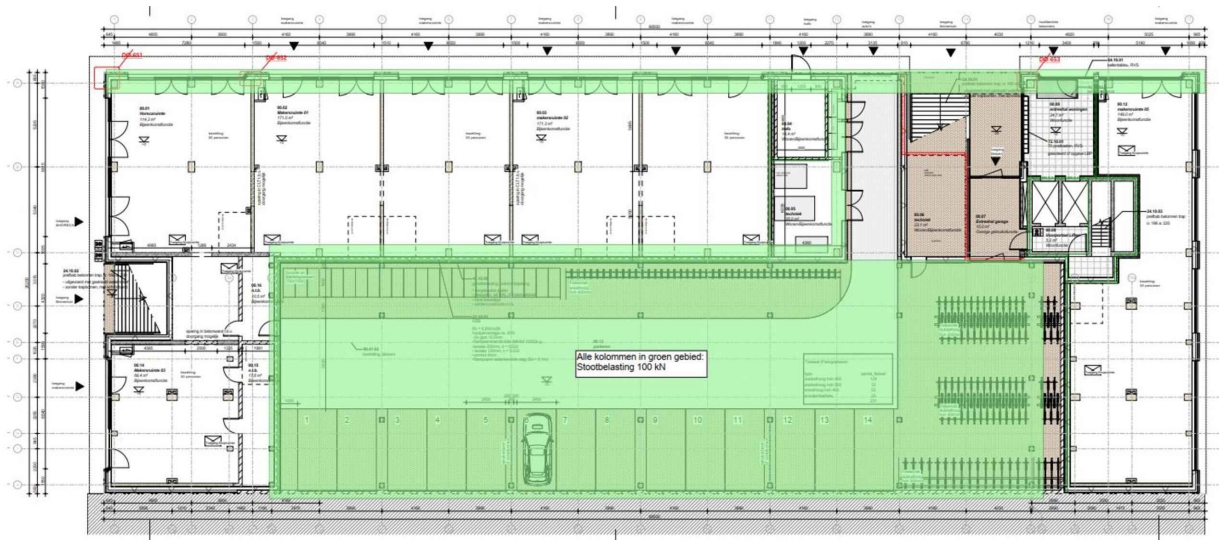

### Verticale belastingen

- Voor de afdracht van de verticale belastingen worden de excentriciteiten van de belasting ten opzichte van de kern van de doorsnede meegenomen en getoetst. Een statische berekening van twee ontwerpsituaties voor de kolommen is toegevoegd aan de bijlage 1.

### ■ 1.3 Brandwerendheid

- De constructie van de parkeergarage, wat een apart brandcompartiment is, staat los van de gebouwconstructie en is gedilateerd langs assen 3a, C en 15b. Voor de galerijen geldt dat die alleen zichzelf dragen en niet de woningen waardoor hierop een aparte brandwerendheid geldt, lees 30 min.
- De houten kolommen langs de parkeergage op as C worden ontworpen op 4-zijdige inbranding voor 120 min, zie de rekennota in bijlage 1.
- Voor opleggingen en connecties met onbeschermde metalen hulpconstructies wordt in de TO-fase de brandwerendheid aangetoond.

### ■ 1.4 Tweede draagweg

- De tweede draagweg wordt opgelost door meerveldsoverspanning van de CLT vloerplaten. Plaatdelingen worden niet aangegeven op de tekeningen van de DO set, die volgen in de TO-fase bij de stukken van de houtleverancier. Wel is de deling gewaarborgd in het ontwerp. De maatgevende situatie is geïdentificeerd en betreft de overspanning tussen as 15 en 17, hiervoor is een controle berekening gemaakt, zie bijlage 2.
- Betreffende de detaillering in relatie tot de robuustheid hoeft niet worden aangetoond dat er voldoende vervormingscapaciteit is. In het geval van het bezwijken van een kolom mag de ligger namelijk volledig van de oplegging af vallen. De vloer is dan in staat om uit te kragen of een grotere overspanning te maken.

## 2 Geotechniek

### ■ 2.2 Paalberekening en tekening palenplan.

- Het palenplan zit in de DO-set. De definitieve maatvoering volgt in de UO-fase. Een paalberekening wordt conform indieningsvereisten in een latere fase ingediend.

### 3 Onderdeel 1: Stabiliteitselementen en element die bij bezwijken tot voortschrijdende instorting kunnen leiden.

#### 3.1 Kernwanden en stabiliteitswanden

- De betonwanden op de assen C en D verzorgen de stabiliteit van het gebouw in lengterichting. Een berekening van deze wanden volgt in de TO-fase.
- Principe details voor de doorkoppeling van CLT wanden staan op de stukken van de houtleverancier. Ter illustratie een van die details, zie onderstaand:

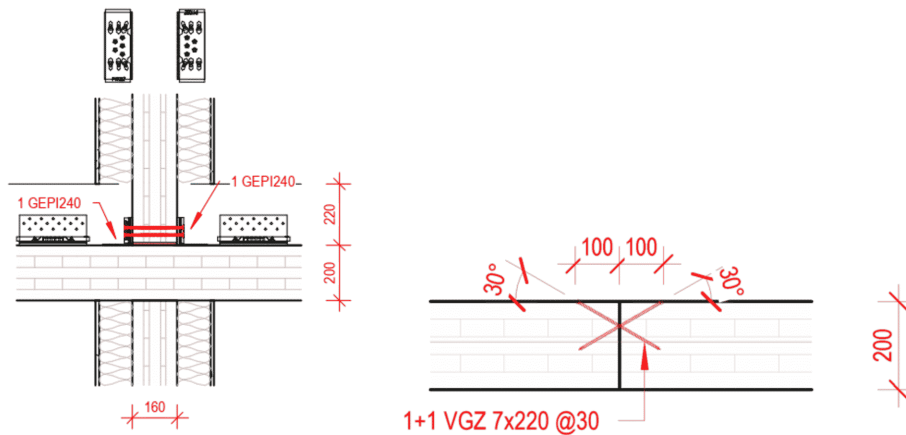

- Principe details voor de doorkoppeling van de vloeren voor schijfwerking, zie rechtsboven.
- Voor alle details en koppelingen volgt in de TO- en UO-fase een nadere en gedetailleerde uitwerking.

### 4 Onderdeel 2: Cruciale verbindingen en uitkragingen

#### 4.1 Momentvaste knopen

- Doorkoppeling CLT stabiliteitswanden is aangegeven op stukken houtleverancier, zie ook principedetail hierboven bij 3.1.

### 7 Onderdeel 5: Platte en schuine daken

#### 7.3 Noodafvoer / wateraccumulatie

- De noodzakelijke afmetingen van de spuwers zijn berekend en indicatief aangegeven op de plattegronden, zie bijlage 3.

### 9 Elementen 2: Overige niet vloerdragende constructies

#### 9.2 Hekwerk

- De noodzakelijke berekeningen voor de hekwerken en diens detaillering behoren niet bij de indieningsvereisten en volgen in een latere fase.

■ Datum: 22 februari 2024

■ Project: Koffiefabriek, Joan Muyskenweg  
19, Amsterdam

■ Betreft: Toetraport - OV - OLO-8325147

■ Ref.nr.: M-321-139-DO-01

## **Bijlage 1 – Afdracht verticale belastingen**

System

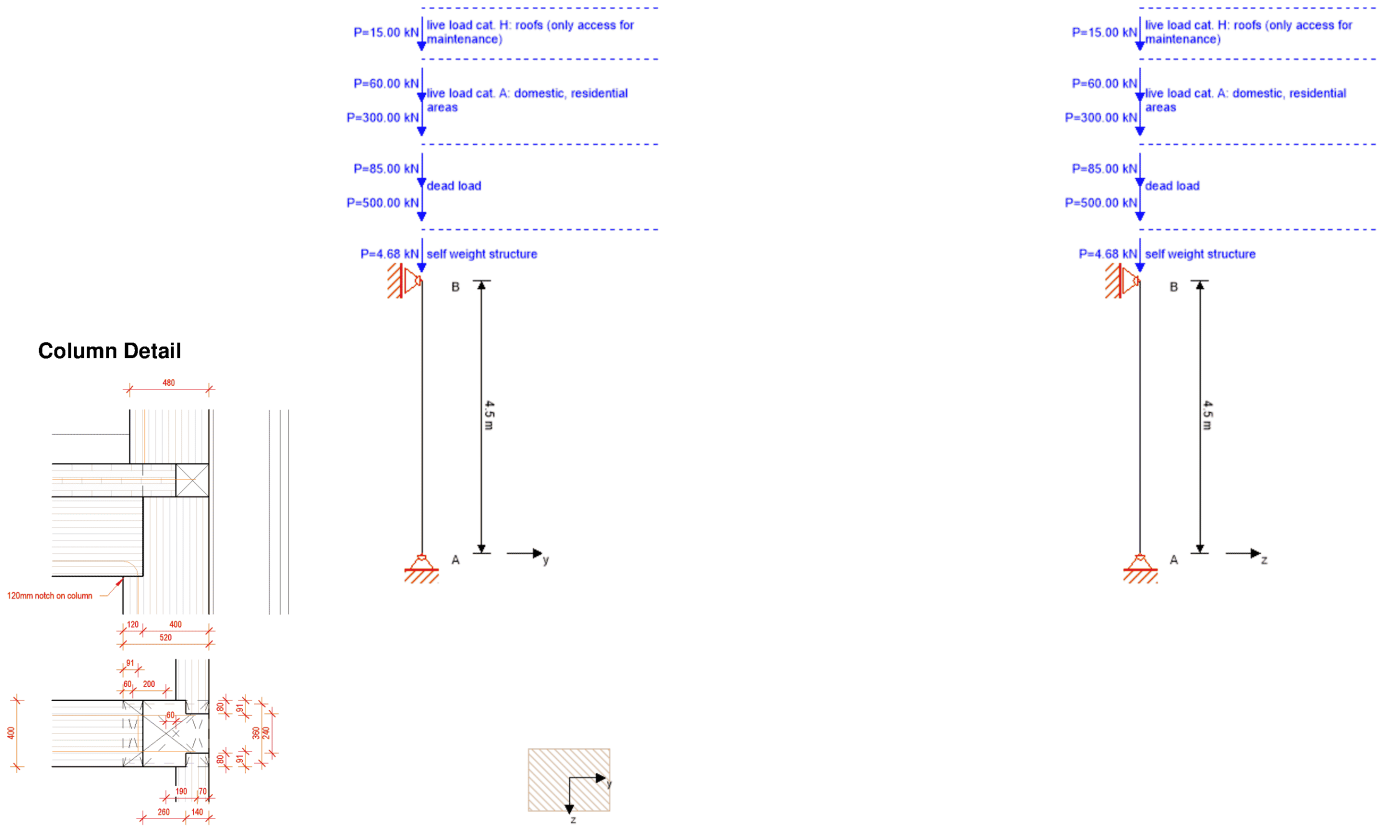

Global utilization ratio

87 %

ULS	71 %	ULS Fire	87 %
-----	------	----------	------

Product data

Section: Wooden beam 52/40

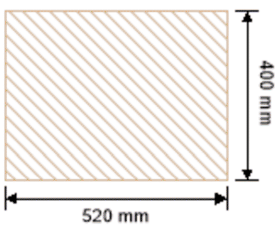

Section width	Section height	Area	$I_y$	$I_z$
[cm]	[cm]	[mm <sup>2</sup> ]	[mm <sup>4</sup> ]	[mm <sup>4</sup> ]
52	40	208,000	2,773,333,000	4,686,932,000

Section Fire: Wooden beam 52/40

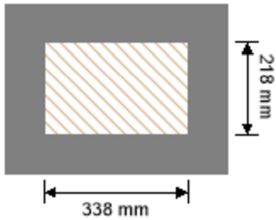

Section width	Section height	Area	ly	lz
[cm]	[cm]	[mm <sup>2</sup> ]	[mm <sup>4</sup> ]	[mm <sup>4</sup> ]
33.8	21.8	73,684	291,813,100	701,495,900

Fire resistance class: R 120

Time **120 min**

Fire protection layering : no additional fire protection

k <sub>0</sub>	d <sub>0</sub>	d <sub>char,0,h</sub>	d <sub>ef,h</sub>	d <sub>char,0,v</sub>	d <sub>ef,v</sub>
[-]	[mm]	[mm]	[mm]	[mm]	[mm]
1	7	84.0	182.0	84.0	182.0

Material values

Material	f <sub>m,k</sub>	f <sub>t,0,k</sub>	f <sub>t,90,k</sub>	f <sub>c,0,k</sub>	f <sub>c,90,k</sub>	f <sub>v,k</sub>	f <sub>r,k min</sub>	E <sub>0,mean</sub>	G <sub>mean</sub>	E <sub>0,5</sub>
	[N/mm <sup>2</sup> ]	[N/mm <sup>2</sup> ]	[N/mm <sup>2</sup> ]	[N/mm <sup>2</sup> ]	[N/mm <sup>2</sup> ]	[N/mm <sup>2</sup> ]	[N/mm <sup>2</sup> ]	[N/mm <sup>2</sup> ]	[N/mm <sup>2</sup> ]	[N/mm <sup>2</sup> ]
GL 24h NBN	24.00	19.20	0.50	24.00	2.50	3.50	1.20	11,500.00	650.00	9,600.00

Load

Load case groups

Load case category	Type	Duration	Kmod	γ <sub>inf</sub>	γ <sub>sup</sub>	Ψ <sub>0</sub>	Ψ <sub>1</sub>	Ψ <sub>2</sub>
LC1 self weight structure	G	permanen	0.6	1	1.35	1	1	1
LC2 dead load	G	permanen	0.6	1	1.35	1	1	1
LC3 live load cat. A: domestic, residential areas	Q	medium term	0.8	0	1.5	0.7	0.5	0.3
LC4 live load cat. H: roofs (only access for maintenance)	Q	short term	0.9	0	1.5	0	0	0

LC1: self weight structure

vertical load

P <sub>k</sub>	ex. y	ex. z
[kN]	[m]	[m]
4.68	0.00	0.00



LIS-KOF\_2D

C-03.0 R+5F\_#C6

TRE baltics

CLT-s

NL23005 - No  
Modular

Germany

Checker

3/12

13/02/2024

#### LC2:dead load

##### vertical load

P <sub>k</sub>	ex. y	ex. z
[kN]	[m]	[m]
500.00	0.08	0.02
85.00	-0.20	0.03

#### LC3:live load cat. A: domestic, residential areas

##### vertical load

P <sub>k</sub>	ex. y	ex. z
[kN]	[m]	[m]
300.00	0.08	0.03
60.00	-0.20	0.03

#### LC4:live load cat. H: roofs (only access for maintenance)

##### vertical load

P <sub>k</sub>	ex. y	ex. z
[kN]	[m]	[m]
15.00	0.08	0.03

#### ULS Combinations

##### Combination rule

LCO1	$1.35/1.00 * LC1 + 1.35/1.00 * LC2$
LCO2	$1.35/1.00 * LC1 + 1.35/1.00 * LC2 + 1.50/0.00 * LC3$
LCO3	$1.35/1.00 * LC1 + 1.35/1.00 * LC2 + 1.50/0.00 * LC3 + 1.50/0.00 * 0.00 * LC4$
LCO4	$1.35/1.00 * LC1 + 1.35/1.00 * LC2 + 1.50/0.00 * LC4$
LCO5	$1.35/1.00 * LC1 + 1.35/1.00 * LC2 + 1.50/0.00 * LC4 + 1.50/0.00 * 0.70 * LC3$

#### ULS Combinations Fire

##### Combination rule

LCO1	$1.00/1.00 * LC1 + 1.00/1.00 * LC2$
LCO2	$1.00/1.00 * LC1 + 1.00/1.00 * LC2 + 1.00/0.00 * 0.30 * LC3$
LCO3	$1.00/1.00 * LC1 + 1.00/1.00 * LC2 + 1.00/0.00 * 0.30 * LC3 + 1.00/0.00 * 0.00 * LC4$



LIS-KOF\_2D

C-03.0 R+5F\_#C6

TRE baltics

CLT-s

NL23005 - No Modular

Germany

Checker

4/12

13/02/2024

**ULS Combinations Fire**

Combination rule

LCO4 1.00/1.00 \* LC1 + 1.00/1.00 \* LC2 + 1.00/0.00 \* 0.00 \* LC4

LCO5 1.00/1.00 \* LC1 + 1.00/1.00 \* LC2 + 1.00/0.00 \* 0.00 \* LC4 + 1.00/0.00 \* 0.30 \* LC3

**Ultimate limit state (ULS) - design results**

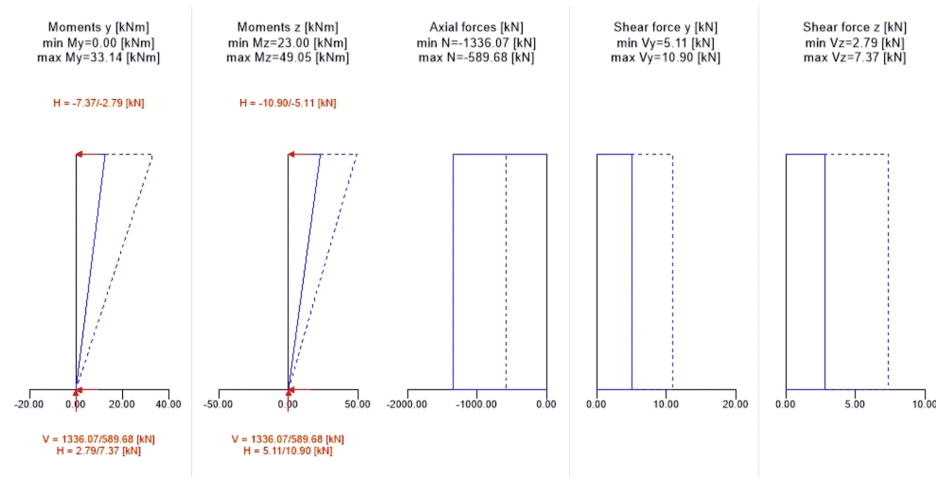

**ULS Flexural design**

Dist.	f <sub>m,k</sub>	f <sub>c,0,k</sub>	f <sub>t,0,k</sub>	γ <sub>m</sub>	k <sub>mod</sub>	k <sub>sys,z</sub>	k <sub>h,m,y</sub>	k <sub>h,m,z</sub>	k <sub>i</sub>	f <sub>m,y,d</sub>	f <sub>m,z,d</sub>	f <sub>t,0,d</sub>	f <sub>c,0,d</sub>
[m]	[N/mm <sup>2</sup> ]	[N/mm <sup>2</sup> ]	[N/mm <sup>2</sup> ]	[-]	[-]	[-]	[-]	[-]	[-]	[N/mm <sup>2</sup> ]	[N/mm <sup>2</sup> ]	[N/mm <sup>2</sup> ]	[N/mm <sup>2</sup> ]
4.5	24.00	24.00	19.20	1.25	0.80	1.00	1.04	1.01	1.00	16.00	15.58	12.29	15.36

M <sub>y,d</sub>	M <sub>z,d</sub>	N <sub>c,d</sub>	N <sub>t,d</sub>	σ <sub>m,y,d</sub>	σ <sub>m,z,d</sub>	σ <sub>c,d</sub>	σ <sub>t,d</sub>	Ratio
[kNm]	[kNm]	[kN]	[kN]	[N/mm <sup>2</sup> ]	[N/mm <sup>2</sup> ]	[N/mm <sup>2</sup> ]	[N/mm <sup>2</sup> ]	
33.14	49.05	-1336.07	0.00	2.39	2.72	6.42	0.00	45% LCO2

**ULS Shear analysis Y**

Dist.	f <sub>v,k</sub>	γ <sub>m</sub>	k <sub>mod</sub>	k <sub>h,v</sub>	f <sub>v,d</sub>	V <sub>d</sub>	τ <sub>v,d</sub>	Ratio
[m]	[N/mm <sup>2</sup> ]	[-]	[-]	[-]	[N/mm <sup>2</sup> ]	[kN]	[N/mm <sup>2</sup> ]	
0.0	3.50	1.25	0.80	1.00	1.50	10.90	0.08	5% LCO2



LIS-KOF\_2D

C-03.0 R+5F\_#C6

TRE baltics

CLT-s

NL23005 - No  
Modular

Germany

Checker

5/12

13/02/2024

**ULS Shear analysis Z**

Dist.	$f_{v,k}$	$\gamma_m$	$k_{mod}$	$k_{h,v}$	$f_{v,d}$	$V_d$	$T_{v,d}$	Ratio	
[m]	[N/mm <sup>2</sup> ]	[-]	[-]	[-]	[N/mm <sup>2</sup> ]	[kN]	[N/mm <sup>2</sup> ]		
0.0	3.50	1.25	0.80	1.00	1.50	7.37	0.05	4%	LCO2

**ULS Shear analysis Combined**

Dist.	$f_{v,k}$	$\gamma_m$	$k_{mod}$	$f_{v,d}$	$V_{y,d}$	$V_{z,d}$	$T_{v,y,d}$	$T_{v,z,d}$	Ratio	
[m]	[N/mm <sup>2</sup> ]	[-]	[-]	[N/mm <sup>2</sup> ]	[kN]	[kN]	[N/mm <sup>2</sup> ]	[N/mm <sup>2</sup> ]		
0.0	3.50	1.25	0.80	1.50	10.90	7.37	0.08	0.05	0%	LCO2

**Flexural stress analysis**

$M_{y,d} =$	33.14	kNm	$f_{m,k} =$	24.00	N/mm <sup>2</sup>
$M_{z,d} =$	49.05	kNm	$f_{m,k,z} =$	24.00	N/mm <sup>2</sup>
$N_{c,d} =$	-	kN	$\gamma_m =$	1.25	-
	1336.07		$k_{mod} =$	0.80	-
			$k_{sys,y} =$	1.00	-
			$k_{h,m,y} =$	1.04	-
			$k_{h,m,z} =$	1.01	-
			$k_i =$	1.00	-
$\sigma_{c,d} =$	6.42	N/mm <sup>2</sup>	$f_{c,0,d} =$	15.36	N/mm <sup>2</sup>
$\sigma_{m,y,d} =$	2.39	N/mm <sup>2</sup>	$f_{m,y,d} =$	16.00	N/mm <sup>2</sup>
$\sigma_{m,z,d} =$	2.72	N/mm <sup>2</sup>	$f_{m,z,d} =$	15.58	N/mm <sup>2</sup> ✓

**Utilization ratio** 45%

**Shear stress analysis Y**

$V_d =$	10.90	kN	$f_{v,k} =$	3.50	N/mm <sup>2</sup>
			$\gamma_m =$	1.25	-
			$k_{mod} =$	0.80	-
			$k_{h,v} =$	1.00	-
$T_{v,d} =$	0.08	N/mm <sup>2</sup>	$f_{v,d} =$	1.50	N/mm <sup>2</sup> ✓

**Utilization ratio** 5%



LIS-KOF\_2D

C-03.0 R+5F\_#C6

TRE baltics

CLT-s

NL23005 - No

Modular

Germany

Checker

6/12

13/02/2024

**Shear stress analysis Z**

$V_{d}$ =	7.37	kN	$f_{v,k}$ =	3.50	N/mm <sup>2</sup>
			$\gamma_m$ =	1.25	-
			$k_{mod}$ =	0.80	-
			$k_{h,v}$ =	1.00	-
$T_{v,d}$ =	0.05	N/mm <sup>2</sup>	$f_{v,d}$ =	1.50	N/mm <sup>2</sup> ✓

**Utilization ratio**

4%

**Shear stress analysis**

$V_{y,d}$ =	10.90	kN	$V_{z,d}$ =	7.37	kN
$f_{v,k}$ =	3.50	N/mm <sup>2</sup>	$\gamma_m$ =	1.25	-
$f_{v,d}$ =	1.50	N/mm <sup>2</sup>	$k_{mod}$ =	0.80	-
$T_{v,y,d}$ =	0.08	N/mm <sup>2</sup>	$T_{v,z,d}$ =	0.05	N/mm <sup>2</sup>

**Utilization ratio**

0%

**Buckling analysis**

$M_{y,d}$ =	33.14	kNm	$f_{m,k}$ =	24.00	N/mm <sup>2</sup>
$M_{z,d}$ =	49.05	kNm			
$N_{c,d}$ =	-	kN	$\gamma_m$ =	1.25	-
	1336.07		$k_{mod}$ =	0.80	-
			$k_{sys,y}$ =	1.00	-
			$k_{sys,z}$ =	1.00	-
			$k_{h,m,y}$ =	1.04	-
			$k_{h,m,z}$ =	1.01	-
$\sigma_{c,d}$ =	6.42	N/mm <sup>2</sup>	$f_{c,0,d}$ =	15.36	N/mm <sup>2</sup>
$\sigma_{m,y,d}$ =	2.39	N/mm <sup>2</sup>	$f_{m,y,d}$ =	16.00	N/mm <sup>2</sup>
$\sigma_{m,z,d}$ =	2.72	N/mm <sup>2</sup>	$f_{m,z,d}$ =	15.58	N/mm <sup>2</sup> ✓

**Utilization ratio**

71%



LIS-KOF\_2D

C-03.0 R+5F\_#C6

TRE baltics

CLT-s

NL23005 - No Modular

Germany

Checker

7/12

13/02/2024

**Lateral torsional buckling analysis**

$M_{y,d} =$	33.14	kNm	$f_{m,k} =$	24.00	N/mm <sup>2</sup>
$M_{z,d} =$	49.05	kNm			
$N_{e,d} =$	-	kN	$\gamma_m =$	1.25	-
	1336.07				
			$k_{mod} =$	0.80	-
			$k_{sys,y} =$	1.00	-
			$k_{h,m,y} =$	1.04	-
			$k_{h,m,z} =$	1.01	-
			$k_i =$	1.00	-
$\sigma_{c,d} =$	6.42	N/mm <sup>2</sup>	$f_{c,0,d} =$	15.36	N/mm <sup>2</sup>
$\sigma_{m,y,d} =$	2.39	N/mm <sup>2</sup>	$f_{m,y,d} =$	16.00	N/mm <sup>2</sup>
$\sigma_{m,z,d} =$	2.72	N/mm <sup>2</sup>	$f_{m,z,d} =$	15.58	N/mm <sup>2</sup> ✓

Utilization ratio

62%

**Ultimate limit state (ULS) fire design - results**

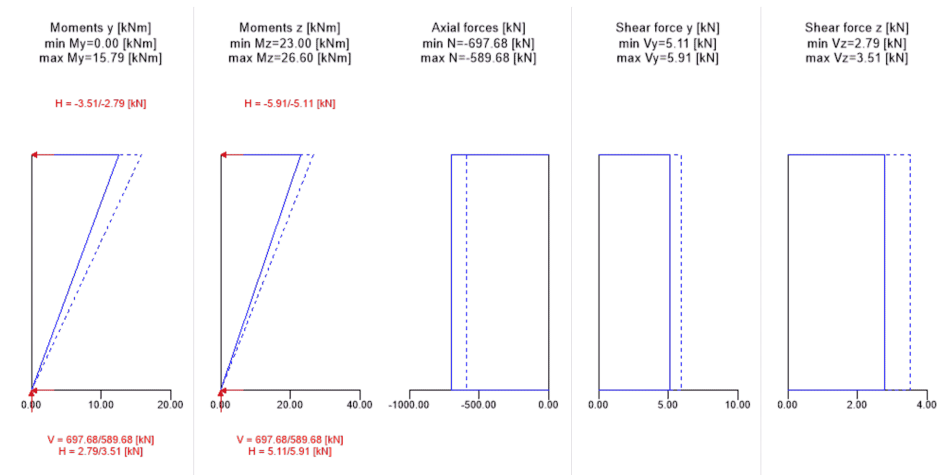

**ULS Fire Flexural design**

Dist.	$\gamma_m$	$k_{mod}$	$k_{sys,y}$	$k_{fi}$	$f_{m,k}$	$f_{m,y,d}$	$f_{t,0,d}$	$f_{c,0,d}$
[m]	[-]	[-]	[-]	[-]	[N/mm <sup>2</sup> ]	[N/mm <sup>2</sup> ]	[N/mm <sup>2</sup> ]	[N/mm <sup>2</sup> ]
4.5	1.25	0.80	1.00	1.00	24.00	16.00	12.29	15.36



LIS-KOF\_2D

C-03.0 R+5F\_#C6

TRE baltics

CLT-s

NL23005 - No  
Modular

Germany

Checker

8/12

13/02/2024

$M_{y,d}$	$N_{c,d}$	$N_{t,d}$	$\sigma_{m,y,d}$	$\sigma_{c,d}$	$\sigma_{t,d}$	Ratio	
[kNm]	[kN]	[kN]	[N/mm <sup>2</sup> ]	[N/mm <sup>2</sup> ]	[N/mm <sup>2</sup> ]		
15.79	- 697.68	0.00	5.90	9.47	0.00	47%	LCO2

ULS Fire Shear analysis Y										
Dist.	$f_{v,k}$	$\gamma_m$	$k_{mod}$	$k_{sys,y}$	$k_{fi}$	$f_{v,d}$	$V_d$	$T_{v,d}$	Ratio	
[m]	[N/mm <sup>2</sup> ]	[-]	[-]	[-]	[-]	[N/mm <sup>2</sup> ]	[kN]	[N/mm <sup>2</sup> ]		
0.0	3.50	1.00	1.00	1.00	1.15	2.70	5.91	0.12	4%	LCO2

ULS Fire Shear analysis Z										
Dist.	$f_{v,k}$	$\gamma_m$	$k_{mod}$	$k_{sys,y}$	$k_{fi}$	$f_{v,d}$	$V_d$	$T_{v,d}$	Ratio	
[m]	[N/mm <sup>2</sup> ]	[-]	[-]	[-]	[-]	[N/mm <sup>2</sup> ]	[kN]	[N/mm <sup>2</sup> ]		
0.0	3.50	1.00	1.00	1.00	1.15	2.70	3.51	0.07	3%	LCO2

ULS Fire Shear analysis Combined												
Dist.	$f_{v,k}$	$\gamma_m$	$k_{mod}$	$k_{sys,y}$	$k_{fi}$	$f_{v,d}$	$V_{y,d}$	$V_{z,d}$	$T_{v,y,d}$	$T_{v,z,d}$	Ratio	
[m]	[N/mm <sup>2</sup> ]	[-]	[-]	[-]	[-]	[N/mm <sup>2</sup> ]	[kN]	[kN]	[N/mm <sup>2</sup> ]	[N/mm <sup>2</sup> ]		
0.0	3.50	1.00	1.00	1.00	1.15	2.70	5.91	3.51	0.12	0.07	0%	LCO2



LIS-KOF\_2D

C-03.0 R+5F\_#C6

TRE baltics

CLT-s

NL23005 - No  
Modular

Germany

Checker

9/12

13/02/2024

### Flexural stress analysis Fire

$M_{y,d} =$	15.79	kNm	$f_{m,k} =$	24.00	N/mm <sup>2</sup>
$M_{z,d} =$	26.60	kNm	$f_{m,k,z} =$	24.00	N/mm <sup>2</sup>
$N_{c,d} =$	-697.68	kN	$\gamma_m =$	1.00	-
			$k_{mod} =$	1.00	-
			$k_{sys,y} =$	1.00	-
			$k_{h,m,y} =$	1.10	-
			$k_{h,m,z} =$	1.06	-
			$k_l =$	1.00	-
			$k_{fi} =$	1.15	-
$\sigma_{c,d} =$	9.47	N/mm <sup>2</sup>	$f_{c,0,d} =$	27.60	N/mm <sup>2</sup>
$\sigma_{m,y,d} =$	5.90	N/mm <sup>2</sup>	$f_{m,y,d} =$	30.36	N/mm <sup>2</sup>
$\sigma_{m,z,d} =$	6.41	N/mm <sup>2</sup>	$f_{m,z,d} =$	29.23	N/mm <sup>2</sup>

Utilization ratio

47%

### Shear stress analysis Y Fire

$V_d =$	5.91	kN	$f_{v,k} =$	3.50	N/mm <sup>2</sup>
			$\gamma_m =$	1.00	-
			$k_{mod} =$	1.00	-
			$k_{h,v} =$	1.00	-
			$k_{fi} =$	1.15	-
$\tau_{v,d} =$	0.12	N/mm <sup>2</sup>	$f_{v,d} =$	2.70	N/mm <sup>2</sup>

Utilization ratio

4%



LIS-KOF\_2D

C-03.0 R+5F\_#C6

TRE baltics

CLT-s

NL23005 - No  
Modular

Germany

Checker

10/12

13/02/2024

**Shear stress analysis Z Fire**

$V_{d,}$	3.51	kN	$f_{v,k}$	3.50	N/mm <sup>2</sup>
			$\gamma_m$	1.00	-
			$k_{mod}$	1.00	-
			$k_{h,v}$	1.00	-
			$k_{fi}$	1.15	-
$T_{v,d}$	0.07	N/mm <sup>2</sup>	$f_{v,d}$	2.70	N/mm <sup>2</sup> ✓

**Utilization ratio**

3%

**Shear stress analysis Fire**

$V_{y,d}$	5.91	kN	$V_{z,d}$	3.51	kN
$f_{v,k}$	3.50	N/mm <sup>2</sup>	$\gamma_m$	1.00	-
			$k_{fi}$	1.15	-
$f_{v,d}$	2.70	N/mm <sup>2</sup>	$k_{mod}$	1.00	-
$T_{v,y,d}$	0.12	N/mm <sup>2</sup>	$T_{v,z,d}$	0.07	N/mm <sup>2</sup>

**Utilization ratio**

0%

**Buckling analysis Fire**

$M_{y,d}$	15.79	kNm	$f_{m,k}$	24.00	N/mm <sup>2</sup>
$M_{z,d}$	26.60	kNm			
$N_{c,d}$	-697.68	kN	$\gamma_m$	1.00	-
			$k_{mod}$	1.00	-
			$k_{sys,y}$	1.00	-
			$k_{sys,z}$	1.00	-
			$k_{h,m,y}$	1.10	-
			$k_{h,m,z}$	1.06	-
			$k_{fi}$	1.15	-
$\sigma_{c,d}$	9.47	N/mm <sup>2</sup>	$f_{c,0,d}$	27.60	N/mm <sup>2</sup>
$\sigma_{m,y,d}$	5.90	N/mm <sup>2</sup>	$f_{m,y,d}$	30.36	N/mm <sup>2</sup>
$\sigma_{m,z,d}$	6.41	N/mm <sup>2</sup>	$f_{m,z,d}$	29.23	N/mm <sup>2</sup> ✓

**Utilization ratio**

87%



LIS-KOF\_2D

C-03.0 R+5F\_#C6

TRE baltics

CLT-s

NL23005 - No  
Modular

Germany

Checker

11/12

13/02/2024

**Lateral torsional buckling analysis Fire**

$M_{y,d} =$	15.79	kNm	$f_{m,k} =$	24.00	N/mm <sup>2</sup>
$M_{z,d} =$	26.60	kNm			
$N_{c,d} =$	-697.68	kN	$\gamma_m =$	1.00	-
			$k_{mod} =$	1.00	-
			$k_{sys,y} =$	1.00	-
			$k_{h,m,y} =$	1.10	-
			$k_{h,m,z} =$	1.06	-
			$k_l =$	1.00	-
			$k_{fi} =$	1.15	-
$\sigma_{c,d} =$	9.47	N/mm <sup>2</sup>	$f_{c,0,d} =$	27.60	N/mm <sup>2</sup>
$\sigma_{m,y,d} =$	5.90	N/mm <sup>2</sup>	$f_{m,y,d} =$	30.36	N/mm <sup>2</sup>
$\sigma_{m,z,d} =$	6.41	N/mm <sup>2</sup>	$f_{m,z,d} =$	29.23	N/mm <sup>2</sup> ✓

Utilization ratio

77%

**Support reaction**

Load case category	$k_{mod}$	$A_y$	$A_z$	$B_x$	$B_y$	$B_z$
		[kN]	[kN]	[kN]	[kN]	[kN]
self weight structure	0.6	0.00	0.00	4.68	0.00	0.00
		0.00	0.00	4.68	0.00	0.00
dead load	0.6	-5.11	-2.79	585.00	5.11	2.79
		-5.11	-2.79	585.00	5.11	2.79
live load cat. A: domestic, residential areas	0.8	0.00	0.00	0.00	2.67	2.40
		-2.67	-2.40	360.00	0.00	0.00
live load cat. H: roofs (only access for maintenance)	0.9	0.00	0.00	0.00	0.27	0.10
		-0.27	-0.10	15.00	0.00	0.00

**Note**

GridLine C6



LIS-KOF\_2D

C-03.0 R+5F\_#C6

TRE baltics

CLT-s

NL23005 - No  
Modular

Germany

Checker

12/12

13/02/2024

**Reference documents for this analysis**

English title	Description
EN 338	EN 338 - Structural timber ? Strength classes
EN 1995-1-1	EN 1995-1-1 - Eurocode 5: Design of timber structures - Part 1-1: General - Common rules and rules for buildings
EN 1995-1-2	EN 1995-1-2 - Eurocode 5 — Design of timber structures — Part 1-2: General — Structural fire design
EN 14080	EN 14080 - Timber Structures - Glued laminated timber and glued solid timber - Requirements
DIN EN 1995-1-1	EN 1995-1-1 - Eurocode 5: Design of timber structures - Part 1-1: General - Common rules and rules for buildings
DIN EN 1995-1-1 NA	EN 1995-1-1 - National Annex – Nationally determined parameters – Eurocode 5: Design of timber structures – Part 1-1: General ? Common rules and rules for buildings
EN 1990	EN 1990 - Eurocode ? Basis of structural design
Fire safety in timber buildings - technical guideline for Europe	Fire safety in timber buildings - technical guideline for Europe; publishes by SP Technical Research Institute of Sweden
National specifications concerning ÖNORM EN 1995-1-2, national comments and national supplements, chapter 12	ÖNORM EN 1995-1-2 - National specifications concerning ÖNORM EN 1995-1-2, national comments and national supplements, chapter 12
DIN EN 1995-1-2_NA	DIN EN 1995-1-2 - Germany - National Annex - Eurocode 5: Design of timber structures ? Part 1-2: General ? Structural fire design ? National specifications concerning DIN EN 1995-1-2, national comments and national supplements
CERTIFICATE NO. EUFI29-20000564-C	Product certificate
LVL G by Stora Enso_Structural design manual column&beam_V01	Design manual
ETA 20_0291 LVL G by Stora Enso	ETA

**Disclaimer**

The software was created to assist engineers in their daily business. The software is an engineering software that is dealing with a very complex matter of structural analysis and building physics analysis. Therefore, this software shall only be operated by skilled, experienced engineers, with a deep understanding of structural engineering and building physics related to timber structures. The user of the software is obliged to check all input values, no matter if they were given by the user or given by default by the software and all results for plausibility. The use of the results of the software should not be relied upon as the basis for any decision or action. Any use of results of the software is only allowed, if the results have been verified and approved regarding completeness and correctness by a project structural/building physics engineer. The user has the possibility to make print-outs from the software. Any modification of those are not allowed. Stora Enso Wood Products GmbH does not assume any warranty regarding the software. The software has been developed with utmost diligence, nevertheless Stora Enso Wood Products GmbH, neither expressly nor implicitly, provides any warranty in terms of accuracy, validity, timeliness and completeness of information and data created by the software. Stora Enso Wood Products GmbH does also not assume any warranty for the general usability of the software, its suitability for a special purpose or for the compatibility of the software with the ones of third party producers or providers. Stora Enso Wood Products GmbH is only liable for damages caused by gross negligence or intent through Stora Enso Wood Products GmbH; the liability for slight negligence is excluded. This does not apply to personal injury. Under the aforementioned conditions Stora Enso Wood Products GmbH is as well not liable for operational failures or the loss of programs and/or data of the user's data processing system. Applicable Law: These terms of use shall be governed by the laws of Austria excluding however any conflict of laws rules and any laws regarding the Convention of the International Sale of Goods (CISG).



Section Fire: Wooden beam 44/40

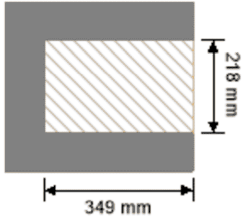

Section width	Section height	Area	ly	lz
[cm]	[cm]	[mm <sup>2</sup> ]	[mm <sup>4</sup> ]	[mm <sup>4</sup> ]
34.9	21.8	76,082	301,310,000	772,238,400

Fire resistance class: R 120

Time **120 min**

Fire protection layering : no additional fire protection

k <sub>0</sub>	d <sub>0</sub>	d <sub>char,0,h</sub>	d <sub>ef,h</sub>	d <sub>char,0,v</sub>	d <sub>ef,v</sub>
[-]	[mm]	[mm]	[mm]	[mm]	[mm]
1	7	84.0	182.0	84.0	91.0

Material values

Material	f <sub>m,k</sub>	f <sub>t,0,k</sub>	f <sub>t,90,k</sub>	f <sub>c,0,k</sub>	f <sub>c,90,k</sub>	f <sub>v,k</sub>	f <sub>r,k min</sub>	E <sub>0,mean</sub>	G <sub>mean</sub>	E <sub>0,5</sub>
	[N/mm <sup>2</sup> ]	[N/mm <sup>2</sup> ]	[N/mm <sup>2</sup> ]	[N/mm <sup>2</sup> ]	[N/mm <sup>2</sup> ]	[N/mm <sup>2</sup> ]	[N/mm <sup>2</sup> ]	[N/mm <sup>2</sup> ]	[N/mm <sup>2</sup> ]	[N/mm <sup>2</sup> ]
GL 24h NBN	24.00	19.20	0.50	24.00	2.50	3.50	1.20	11,500.00	650.00	9,600.00

Load

Load case groups

Load case category	Type	Duration	Kmod	γ <sub>inf</sub>	γ <sub>sup</sub>	Ψ <sub>0</sub>	Ψ <sub>1</sub>	Ψ <sub>2</sub>
LC1 self weight structure	G	permanen	0.6	1	1.35	1	1	1
LC2 dead load	G	permanen	0.6	1	1.35	1	1	1
LC3 live load cat. A: domestic, residential areas	Q	medium term	0.8	0	1.5	0.7	0.5	0.3
LC4 live load cat. H: roofs (only access for maintenance)	Q	short term	0.9	0	1.5	0	0	0

LC1: self weight structure

vertical load

P <sub>k</sub>	ex. y	ex. z
[kN]	[m]	[m]
3.96	0.00	0.00



LIS-KOF\_2D

C-02.0 R+5F\_#A4

TRE baltics

CLT-s

NL23005 - No  
Modular

Germany

Checker

3/12

13/02/2024

### LC2:dead load

#### vertical load

P <sub>k</sub>	ex. y	ex. z
[kN]	[m]	[m]
370.00	0.08	0.03
70.00	-0.16	0.03
60.00	0.17	0.03

### LC3:live load cat. A: domestic, residential areas

#### vertical load

P <sub>k</sub>	ex. y	ex. z
[kN]	[m]	[m]
20.00	-0.16	0.02
160.00	0.08	0.02

### LC4:live load cat. H: roofs (only access for maintenance)

#### vertical load

P <sub>k</sub>	ex. y	ex. z
[kN]	[m]	[m]
20.00	0.08	0.03

### ULS Combinations

#### Combination rule

LCO1	$1.35/1.00 * LC1 + 1.35/1.00 * LC2$
LCO2	$1.35/1.00 * LC1 + 1.35/1.00 * LC2 + 1.50/0.00 * LC3$
LCO3	$1.35/1.00 * LC1 + 1.35/1.00 * LC2 + 1.50/0.00 * LC3 + 1.50/0.00 * 0.00 * LC4$
LCO4	$1.35/1.00 * LC1 + 1.35/1.00 * LC2 + 1.50/0.00 * LC4$
LCO5	$1.35/1.00 * LC1 + 1.35/1.00 * LC2 + 1.50/0.00 * LC4 + 1.50/0.00 * 0.70 * LC3$

### ULS Combinations Fire

#### Combination rule

LCO1	$1.00/1.00 * LC1 + 1.00/1.00 * LC2$
LCO2	$1.00/1.00 * LC1 + 1.00/1.00 * LC2 + 1.00/0.00 * 0.30 * LC3$
LCO3	$1.00/1.00 * LC1 + 1.00/1.00 * LC2 + 1.00/0.00 * 0.30 * LC3 + 1.00/0.00 * 0.00 * LC4$



LIS-KOF\_2D

C-02.0 R+5F\_#A4

TRE baltics

CLT-s

NL23005 - No Modular

Germany

Checker

4/12

13/02/2024

**ULS Combinations Fire**

Combination rule

LCO4 1.00/1.00 \* LC1 + 1.00/1.00 \* LC2 + 1.00/0.00 \* 0.00 \* LC4

LCO5 1.00/1.00 \* LC1 + 1.00/1.00 \* LC2 + 1.00/0.00 \* 0.00 \* LC4 + 1.00/0.00 \* 0.30 \* LC3

**Ultimate limit state (ULS) - design results**

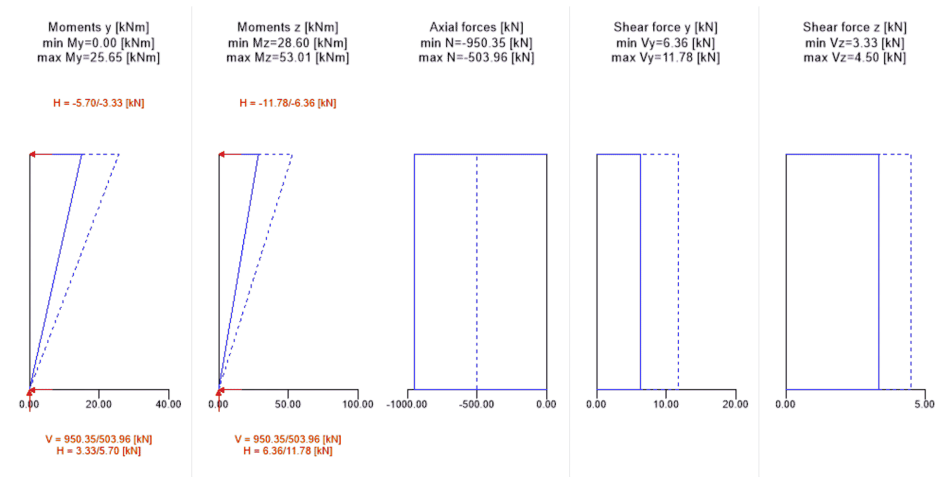

**ULS Flexural design**

Dist.	f <sub>m,k</sub>	f <sub>c,0,k</sub>	f <sub>t,0,k</sub>	γ <sub>m</sub>	k <sub>mod</sub>	k <sub>sys,z</sub>	k <sub>h,m,y</sub>	k <sub>h,m,z</sub>	k <sub>i</sub>	f <sub>m,y,d</sub>	f <sub>m,z,d</sub>	f <sub>t,0,d</sub>	f <sub>c,0,d</sub>
[m]	[N/mm <sup>2</sup> ]	[N/mm <sup>2</sup> ]	[N/mm <sup>2</sup> ]	[-]	[-]	[-]	[-]	[-]	[-]	[N/mm <sup>2</sup> ]	[N/mm <sup>2</sup> ]	[N/mm <sup>2</sup> ]	[N/mm <sup>2</sup> ]
4.5	24.00	24.00	19.20	1.25	0.80	1.00	1.04	1.03	1.00	16.00	15.84	12.29	15.36

M <sub>y,d</sub>	M <sub>z,d</sub>	N <sub>c,d</sub>	N <sub>t,d</sub>	σ <sub>m,y,d</sub>	σ <sub>m,z,d</sub>	σ <sub>c,d</sub>	σ <sub>t,d</sub>	Ratio
[kNm]	[kNm]	[kN]	[kN]	[N/mm <sup>2</sup> ]	[N/mm <sup>2</sup> ]	[N/mm <sup>2</sup> ]	[N/mm <sup>2</sup> ]	
25.65	53.01	-950.35	0.00	2.19	4.11	5.40	0.00	48% LCO2

**ULS Shear analysis Y**

Dist.	f <sub>v,k</sub>	γ <sub>m</sub>	k <sub>mod</sub>	k <sub>h,v</sub>	f <sub>v,d</sub>	V <sub>d</sub>	τ <sub>v,d</sub>	Ratio
[m]	[N/mm <sup>2</sup> ]	[-]	[-]	[-]	[N/mm <sup>2</sup> ]	[kN]	[N/mm <sup>2</sup> ]	
0.0	3.50	1.25	0.80	1.00	1.50	11.78	0.10	7% LCO2



LIS-KOF\_2D

C-02.0 R+5F\_#A4

TRE baltics

CLT-s

NL23005 - No

Modular

Germany

Checker

5/12

13/02/2024

ULS Shear analysis Z

Dist.	$f_{v,k}$	$\gamma_m$	$k_{mod}$	$k_{h,v}$	$f_{v,d}$	$V_d$	$T_{v,d}$	Ratio
[m]	[N/mm <sup>2</sup> ]	[-]	[-]	[-]	[N/mm <sup>2</sup> ]	[kN]	[N/mm <sup>2</sup> ]	
0.0	3.50	1.25	0.60	1.00	1.13	4.50	0.04	3% LCO1

ULS Shear analysis Combined

Dist.	$f_{v,k}$	$\gamma_m$	$k_{mod}$	$f_{v,d}$	$V_{y,d}$	$V_{z,d}$	$T_{v,y,d}$	$T_{v,z,d}$	Ratio
[m]	[N/mm <sup>2</sup> ]	[-]	[-]	[N/mm <sup>2</sup> ]	[kN]	[kN]	[N/mm <sup>2</sup> ]	[N/mm <sup>2</sup> ]	
0.0	3.50	1.25	0.80	1.50	11.78	5.70	0.10	0.05	1% LCO2

Flexural stress analysis

$M_{y,d} =$	25.65	kNm	$f_{m,k} =$	24.00	N/mm <sup>2</sup>
$M_{z,d} =$	53.01	kNm	$f_{m,k,z} =$	24.00	N/mm <sup>2</sup>
$N_{c,d} =$	-950.35	kN	$\gamma_m =$	1.25	-
			$k_{mod} =$	0.80	-
			$k_{sys,y} =$	1.00	-
			$k_{h,m,y} =$	1.04	-
			$k_{h,m,z} =$	1.03	-
			$k_l =$	1.00	-
$\sigma_{c,d} =$	5.40	N/mm <sup>2</sup>	$f_{c,0,d} =$	15.36	N/mm <sup>2</sup>
$\sigma_{m,y,d} =$	2.19	N/mm <sup>2</sup>	$f_{m,y,d} =$	16.00	N/mm <sup>2</sup>
$\sigma_{m,z,d} =$	4.11	N/mm <sup>2</sup>	$f_{m,z,d} =$	15.84	N/mm <sup>2</sup> ✓

Utilization ratio 48%

Shear stress analysis Y

$V_d =$	11.78	kN	$f_{v,k} =$	3.50	N/mm <sup>2</sup>
			$\gamma_m =$	1.25	-
			$k_{mod} =$	0.80	-
			$k_{h,v} =$	1.00	-
$T_{v,d} =$	0.10	N/mm <sup>2</sup>	$f_{v,d} =$	1.50	N/mm <sup>2</sup> ✓

Utilization ratio 7%



LIS-KOF\_2D

C-02.0 R+5F\_#A4

TRE baltics

CLT-s

NL23005 - No  
Modular

Germany

Checker

6/12

13/02/2024

**Shear stress analysis Z**

$V_{d}$ =	4.50	kN	$f_{v,k}$ =	3.50	N/mm <sup>2</sup>
			$\gamma_m$ =	1.25	-
			$k_{mod}$ =	0.60	-
			$k_{h,v}$ =	1.00	-
$T_{v,d}$ =	0.04	N/mm <sup>2</sup>	$f_{v,d}$ =	1.13	N/mm <sup>2</sup> ✓

**Utilization ratio** 3%**Shear stress analysis**

$V_{y,d}$ =	11.78	kN	$V_{z,d}$ =	5.70	kN
$f_{v,k}$ =	3.50	N/mm <sup>2</sup>	$\gamma_m$ =	1.25	-
$f_{v,d}$ =	1.50	N/mm <sup>2</sup>	$k_{mod}$ =	0.80	-
$T_{v,y,d}$ =	0.10	N/mm <sup>2</sup>	$T_{v,z,d}$ =	0.05	N/mm <sup>2</sup>

**Utilization ratio** 1%**Buckling analysis**

$M_{y,d}$ =	25.65	kNm	$f_{m,k}$ =	24.00	N/mm <sup>2</sup>
$M_{z,d}$ =	53.01	kNm			
$N_{c,d}$ =	-950.35	kN	$\gamma_m$ =	1.25	-
			$k_{mod}$ =	0.80	-
			$k_{sys,y}$ =	1.00	-
			$k_{sys,z}$ =	1.00	-
			$k_{h,m,y}$ =	1.04	-
			$k_{h,m,z}$ =	1.03	-
$\sigma_{c,d}$ =	5.40	N/mm <sup>2</sup>	$f_{c,0,d}$ =	15.36	N/mm <sup>2</sup>
$\sigma_{m,y,d}$ =	2.19	N/mm <sup>2</sup>	$f_{m,y,d}$ =	16.00	N/mm <sup>2</sup>
$\sigma_{m,z,d}$ =	4.11	N/mm <sup>2</sup>	$f_{m,z,d}$ =	15.84	N/mm <sup>2</sup> ✓

**Utilization ratio** 72%



LIS-KOF\_2D

C-02.0 R+5F\_#A4

TRE baltics

CLT-s

NL23005 - No Modular

Germany

Checker

7/12

13/02/2024

**Lateral torsional buckling analysis**

$M_{y,d} =$	25.65	kNm	$f_{m,k} =$	24.00	N/mm <sup>2</sup>
$M_{z,d} =$	53.01	kNm			
$N_{e,d} =$	-950.35	kN	$\gamma_m =$	1.25	-
			$k_{mod} =$	0.80	-
			$k_{sys,y} =$	1.00	-
			$k_{h,m,y} =$	1.04	-
			$k_{h,m,z} =$	1.03	-
			$k_l =$	1.00	-
$\sigma_{e,d} =$	5.40	N/mm <sup>2</sup>	$f_{e,0,d} =$	15.36	N/mm <sup>2</sup>
$\sigma_{m,y,d} =$	2.19	N/mm <sup>2</sup>	$f_{m,y,d} =$	16.00	N/mm <sup>2</sup>
$\sigma_{m,z,d} =$	4.11	N/mm <sup>2</sup>	$f_{m,z,d} =$	15.84	N/mm <sup>2</sup> ✓

Utilization ratio

64%

**Ultimate limit state (ULS) fire design - results**

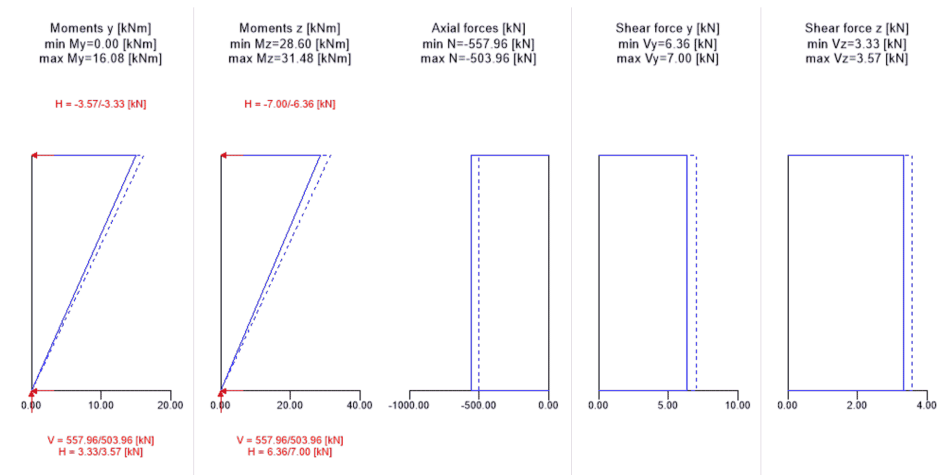

**ULS Fire Flexural design**

Dist.	$\gamma_m$	$k_{mod}$	$k_{sys,y}$	$k_{fi}$	$f_{m,k}$	$f_{m,y,d}$	$f_{t,0,d}$	$f_{c,0,d}$
[m]	[-]	[-]	[-]	[-]	[N/mm <sup>2</sup> ]	[N/mm <sup>2</sup> ]	[N/mm <sup>2</sup> ]	[N/mm <sup>2</sup> ]
4.5	1.25	0.80	1.00	1.00	24.00	16.00	12.29	15.36



LIS-KOF\_2D

C-02.0 R+5F\_#A4

TRE baltics

CLT-s

NL23005 - No  
Modular

Germany

Checker

8/12

13/02/2024

$M_{y,d}$	$N_{c,d}$	$N_{t,d}$	$\sigma_{m,y,d}$	$\sigma_{c,d}$	$\sigma_{t,d}$	Ratio	
[kNm]	[kN]	[kN]	[N/mm <sup>2</sup> ]	[N/mm <sup>2</sup> ]	[N/mm <sup>2</sup> ]		
16.08	- 557.96	0.00	5.82	7.33	0.00	45%	LCO2

ULS Fire Shear analysis Y										
Dist.	$f_{v,k}$	$\gamma_m$	$k_{mod}$	$k_{sys,y}$	$k_{fi}$	$f_{v,d}$	$V_d$	$T_{v,d}$	Ratio	
[m]	[N/mm <sup>2</sup> ]	[-]	[-]	[-]	[-]	[N/mm <sup>2</sup> ]	[kN]	[N/mm <sup>2</sup> ]		
0.0	3.50	1.00	1.00	1.00	1.15	2.70	7.00	0.14	5%	LCO2

ULS Fire Shear analysis Z										
Dist.	$f_{v,k}$	$\gamma_m$	$k_{mod}$	$k_{sys,y}$	$k_{fi}$	$f_{v,d}$	$V_d$	$T_{v,d}$	Ratio	
[m]	[N/mm <sup>2</sup> ]	[-]	[-]	[-]	[-]	[N/mm <sup>2</sup> ]	[kN]	[N/mm <sup>2</sup> ]		
0.0	3.50	1.00	1.00	1.00	1.15	2.70	3.57	0.07	3%	LCO2

ULS Fire Shear analysis Combined												
Dist.	$f_{v,k}$	$\gamma_m$	$k_{mod}$	$k_{sys,y}$	$k_{fi}$	$f_{v,d}$	$V_{y,d}$	$V_{z,d}$	$T_{v,y,d}$	$T_{v,z,d}$	Ratio	
[m]	[N/mm <sup>2</sup> ]	[-]	[-]	[-]	[-]	[N/mm <sup>2</sup> ]	[kN]	[kN]	[N/mm <sup>2</sup> ]	[N/mm <sup>2</sup> ]		
0.0	3.50	1.00	1.00	1.00	1.15	2.70	7.00	3.57	0.14	0.07	0%	LCO2



LIS-KOF\_2D

C-02.0 R+5F\_#A4

TRE baltics

CLT-s

NL23005 - No  
Modular

Germany

Checker

9/12

13/02/2024

### Flexural stress analysis Fire

$M_{y,d} =$	16.08	kNm	$f_{m,k} =$	24.00	N/mm <sup>2</sup>
$M_{z,d} =$	31.48	kNm	$f_{m,k,z} =$	24.00	N/mm <sup>2</sup>
$N_{c,d} =$	-557.96	kN	$\gamma_m =$	1.00	-
			$k_{mod} =$	1.00	-
			$k_{sys,y} =$	1.00	-
			$k_{h,m,y} =$	1.10	-
			$k_{h,m,z} =$	1.06	-
			$k_l =$	1.00	-
			$k_{fi} =$	1.15	-
$\sigma_{c,d} =$	7.33	N/mm <sup>2</sup>	$f_{c,0,d} =$	27.60	N/mm <sup>2</sup>
$\sigma_{m,y,d} =$	5.82	N/mm <sup>2</sup>	$f_{m,y,d} =$	30.36	N/mm <sup>2</sup>
$\sigma_{m,z,d} =$	7.11	N/mm <sup>2</sup>	$f_{m,z,d} =$	29.14	N/mm <sup>2</sup>

Utilization ratio

45%

### Shear stress analysis Y Fire

$V_d =$	7.00	kN	$f_{v,k} =$	3.50	N/mm <sup>2</sup>
			$\gamma_m =$	1.00	-
			$k_{mod} =$	1.00	-
			$k_{h,v} =$	1.00	-
			$k_{fi} =$	1.15	-
$\tau_{v,d} =$	0.14	N/mm <sup>2</sup>	$f_{v,d} =$	2.70	N/mm <sup>2</sup>

Utilization ratio

5%



LIS-KOF\_2D

C-02.0 R+5F\_#A4

TRE baltics

CLT-s

NL23005 - No

Modular

Germany

Checker

10/12

13/02/2024

**Shear stress analysis Z Fire**

$V_{d}$ =	3.57	kN	$f_{v,k}$ =	3.50	N/mm <sup>2</sup>
			$\gamma_m$ =	1.00	-
			$k_{mod}$ =	1.00	-
			$k_{h,v}$ =	1.00	-
			$k_{fi}$ =	1.15	-
$\tau_{v,d}$ =	0.07	N/mm <sup>2</sup>	$f_{v,d}$ =	2.70	N/mm <sup>2</sup>

**Utilization ratio**

3%

**Shear stress analysis Fire**

$V_{y,d}$ =	7.00	kN	$V_{z,d}$ =	3.57	kN
$f_{v,k}$ =	3.50	N/mm <sup>2</sup>	$\gamma_m$ =	1.00	-
			$k_{fi}$ =	1.15	-
$f_{v,d}$ =	2.70	N/mm <sup>2</sup>	$k_{mod}$ =	1.00	-
$\tau_{v,y,d}$ =	0.14	N/mm <sup>2</sup>	$\tau_{v,z,d}$ =	0.07	N/mm <sup>2</sup>

**Utilization ratio**

0%

**Buckling analysis Fire**

$M_{y,d}$ =	16.08	kNm	$f_{m,k}$ =	24.00	N/mm <sup>2</sup>
$M_{z,d}$ =	31.48	kNm			
$N_{c,d}$ =	-557.96	kN	$\gamma_m$ =	1.00	-
			$k_{mod}$ =	1.00	-
			$k_{sys,y}$ =	1.00	-
			$k_{sys,z}$ =	1.00	-
			$k_{h,m,y}$ =	1.10	-
			$k_{h,m,z}$ =	1.06	-
			$k_{fi}$ =	1.15	-
$\sigma_{c,d}$ =	7.33	N/mm <sup>2</sup>	$f_{c,0,d}$ =	27.60	N/mm <sup>2</sup>
$\sigma_{m,y,d}$ =	5.82	N/mm <sup>2</sup>	$f_{m,y,d}$ =	30.36	N/mm <sup>2</sup>
$\sigma_{m,z,d}$ =	7.11	N/mm <sup>2</sup>	$f_{m,z,d}$ =	29.14	N/mm <sup>2</sup>

**Utilization ratio**

77%



LIS-KOF\_2D

C-02.0 R+5F\_#A4

TRE baltics

CLT-s

NL23005 - No Modular

Germany

Checker

11/12

13/02/2024

**Lateral torsional buckling analysis Fire**

$M_{y,d} =$	16.08	kNm	$f_{m,k} =$	24.00	N/mm <sup>2</sup>
$M_{z,d} =$	31.48	kNm			
$N_{c,d} =$	-557.96	kN	$\gamma_m =$	1.00	-
			$k_{mod} =$	1.00	-
			$k_{sys,y} =$	1.00	-
			$k_{h,m,y} =$	1.10	-
			$k_{h,m,z} =$	1.06	-
			$k_l =$	1.00	-
			$k_{fi} =$	1.15	-
$\sigma_{c,d} =$	7.33	N/mm <sup>2</sup>	$f_{c,0,d} =$	27.60	N/mm <sup>2</sup>
$\sigma_{m,y,d} =$	5.82	N/mm <sup>2</sup>	$f_{m,y,d} =$	30.36	N/mm <sup>2</sup>
$\sigma_{m,z,d} =$	7.11	N/mm <sup>2</sup>	$f_{m,z,d} =$	29.14	N/mm <sup>2</sup> ✓

**Utilization ratio** 66%

**Support reaction**

Load case category	$k_{mod}$	$A_y$	$A_z$	$B_x$	$B_y$	$B_z$
		[kN]	[kN]	[kN]	[kN]	[kN]
self weight structure	0.6	0.00	0.00	3.96	0.00	0.00
		0.00	0.00	3.96	0.00	0.00
dead load	0.6	-6.36	-3.33	500.00	6.36	3.33
		-6.36	-3.33	500.00	6.36	3.33
live load cat. A: domestic, residential areas	0.8	0.00	0.00	0.00	2.13	0.80
		-2.13	-0.80	180.00	0.00	0.00
live load cat. H: roofs (only access for maintenance)	0.9	0.00	0.00	0.00	0.36	0.13
		-0.36	-0.13	20.00	0.00	0.00

**Note**

GridLine A4, A6, A8, A10



LIS-KOF\_2D

C-02.0 R+5F\_#A4

TRE baltics

CLT-s

NL23005 - No  
Modular

Germany

Checker

12/12

13/02/2024

### Reference documents for this analysis

English title	Description
EN 338	EN 338 - Structural timber ? Strength classes
EN 1995-1-1	EN 1995-1-1 - Eurocode 5: Design of timber structures - Part 1-1: General - Common rules and rules for buildings
EN 1995-1-2	EN 1995-1-2 - Eurocode 5 — Design of timber structures — Part 1-2: General — Structural fire design
EN 14080	EN 14080 - Timber Structures - Glued laminated timber and glued solid timber - Requirements
DIN EN 1995-1-1	EN 1995-1-1 - Eurocode 5: Design of timber structures - Part 1-1: General - Common rules and rules for buildings
DIN EN 1995-1-1 NA	EN 1995-1-1 - National Annex – Nationally determined parameters – Eurocode 5: Design of timber structures – Part 1-1: General ? Common rules and rules for buildings
EN 1990	EN 1990 - Eurocode ? Basis of structural design
Fire safety in timber buildings - technical guideline for Europe	Fire safety in timber buildings - technical guideline for Europe; publishes by SP Technical Research Institute of Sweden
National specifications concerning ÖNORM EN 1995-1-2, national comments and national supplements, chapter 12	ÖNORM EN 1995-1-2 - National specifications concerning ÖNORM EN 1995-1-2, national comments and national supplements, chapter 12
DIN EN 1995-1-2_NA	DIN EN 1995-1-2 - Germany - National Annex - Eurocode 5: Design of timber structures ? Part 1-2: General ? Structural fire design ? National specifications concerning DIN EN 1995-1-2, national comments and national supplements
CERTIFICATE NO. EUFI29-20000564-C	Product certificate
LVL G by Stora Enso_Structural design manual column&beam_V01	Design manual
ETA 20_0291 LVL G by Stora Enso	ETA

### Disclaimer

The software was created to assist engineers in their daily business. The software is an engineering software that is dealing with a very complex matter of structural analysis and building physics analysis. Therefore, this software shall only be operated by skilled, experienced engineers, with a deep understanding of structural engineering and building physics related to timber structures. The user of the software is obliged to check all input values, no matter if they were given by the user or given by default by the software and all results for plausibility. The use of the results of the software should not be relied upon as the basis for any decision or action. Any use of results of the software is only allowed, if the results have been verified and approved regarding completeness and correctness by a project structural/building physics engineer. The user has the possibility to make print-outs from the software. Any modification of those are not allowed. Stora Enso Wood Products GmbH does not assume any warranty regarding the software. The software has been developed with utmost diligence, nevertheless Stora Enso Wood Products GmbH, neither expressly nor implicitly, provides any warranty in terms of accuracy, validity, timeliness and completeness of information and data created by the software. Stora Enso Wood Products GmbH does also not assume any warranty for the general usability of the software, its suitability for a special purpose or for the compatibility of the software with the ones of third party producers or providers. Stora Enso Wood Products GmbH is only liable for damages caused by gross negligence or intent through Stora Enso Wood Products GmbH; the liability for slight negligence is excluded. This does not apply to personal injury. Under the aforementioned conditions Stora Enso Wood Products GmbH is as well not liable for operational failures or the loss of programs and/or data of the user's data processing system. Applicable Law: These terms of use shall be governed by the laws of Austria excluding however any conflict of laws rules and any laws regarding the Convention of the International Sale of Goods (CISG).

■ Datum: 22 februari 2024

■ Project: Koffiefabriek, Joan Muyskenweg  
19, Amsterdam

■ Betreft: Toetraapport - OV - OLO-8325147

■ Ref.nr.: M-321-139-DO-01

## **Bijlage 2 – Controle tweede draagweg**

Controle robuïsheid / tweede draagweg

- CLT vloer op As 1-3

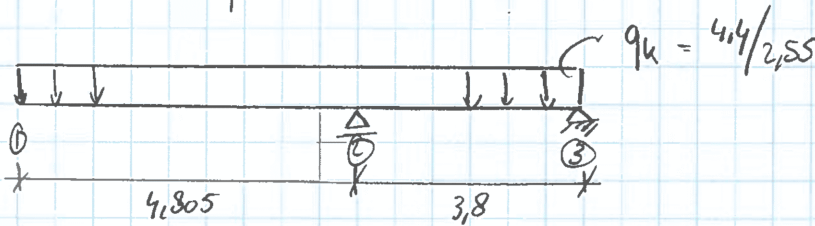

buitengewoon:

$$q_{ed} = \sum G_k + \psi_2 \sum Q_k$$

$$= G_k + 0,3 \cdot Q_k$$

$$= 5,165 \text{ kN/m}$$

Material: CLT 200,  $\rightarrow I_y = 5,28 \cdot 10^8 \text{ mm}^4$ ,  $W_y = 5,28 \cdot 10^6 \text{ mm}^3$

$$f_{m,k} = 24 \text{ N/mm}^2 \rightarrow f_{m,d} = 1,1 \cdot \frac{24}{1,0}$$

$$= 26,4 \text{ N/mm}^2$$

Controle:

$$M_{max} = \frac{1}{2} q_{ed} \cdot l^2 = \frac{1}{2} \cdot 5,165 \cdot 4,805^2 = 60 \text{ kNm}$$

$$\sigma = \frac{M}{W} = \frac{60 \cdot 10^6}{5,28 \cdot 10^6} = 11,4 \text{ N/mm}^2 < 26,4 \text{ N/mm}^2 \rightarrow \text{Akkoord}$$

Reacties:

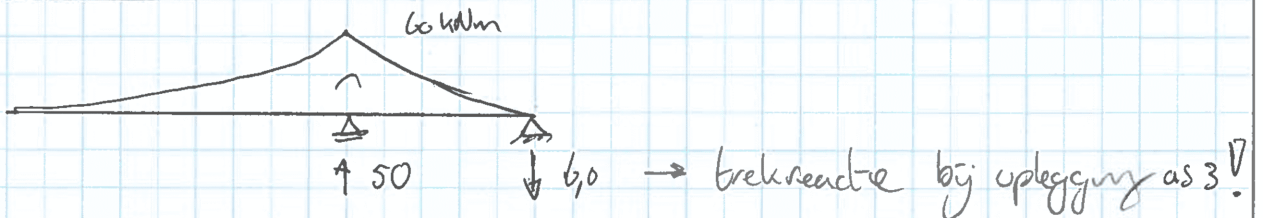

In het geval van vloerplaat op As 15 - 17 :

overspanning is 4.805 + 5.025

$$M_{max} = 1/2 \times 5.165 \times 5.025^2 = 65.21 \text{ kNm}$$

$$\sigma_{max} = 65.21/60 \times 11.4 = 12.38 \text{ N/mm}^2 \ll f_{m,d}$$

Conclusie ook op maatgevende overspanning voldoet de tweede draagweg.

■ Datum: 22 februari 2024

■ Project: Koffiefabriek, Joan Muyskenweg  
19, Amsterdam

■ Betreft: Toetraport - OV - OLO-8325147

■ Ref.nr.: M-321-139-DO-01

### **Bijlage 3 – Noodoverstorten**

- legenda**
- Alle maten in het werk te controleren. Terreinmaten zijn indicatief
  - Alle maten in mm
  - Materiaalcodes vlgv bijbehorende materiaalstaat
  - Materiaalcodes getken voor het gehele vlak, tenzij anders aangegeven.
  - P=0 = bovenkant afgewerkte begane grondvloer = 0.70+ NAP (volgens 30030220 Levening kaveld gemeente Amsterdam)
  - Eeventueel getkende losse richting valt buiten het bouwkundig bestek, tenzij anders aangegeven
  - Vloeroppervlaktes volgens NEN 2580
  - Integrale toegankelijkheid en toegankelijkheid van ruimten. Vrije doorgang en drempelhoogten voldoen aan de eisen zoals vermeld in onderstaande artikelen:  
 1. Projecten vergoed volgens Bouwbesluit 2012 art. 4.21, 4.22 en 4.27  
 2. Projecten vergoed volgens BBL: Bestaande bouw: art. 3.59 en 3.98 -  
 3. Nieuwbouw: art. 4.73, 4.78, 4.160 t/m 4.162 en 6.22
  - maatvoering vloerplaketten ter plaatse van opleggingen
  - te openen ramen en deuren in interne brand- en rookschelingen zijn zelfsluitend
  - aangegeven 'hergebruikte materialen' zijn indicatief weergegeven, definitieve plaatsverdeling, maatvoering en uitvoering ter controle aan architect voorleggen.
  - Brandveiligheid of opgave LBP (integrale advisering brandveiligheid)
  - R0- en U-waarden conform rapportage LBP (integrale advisering bouwfysica)
  - Draagconstructies of opgave Pieters Bouwtechniek (integrale advisering draagconstructies)
  - Acoestiek of opgave Peutz (integrale advisering akoestiek)
  - Acoestiek of opgave Merssch (integrale advisering installaties)

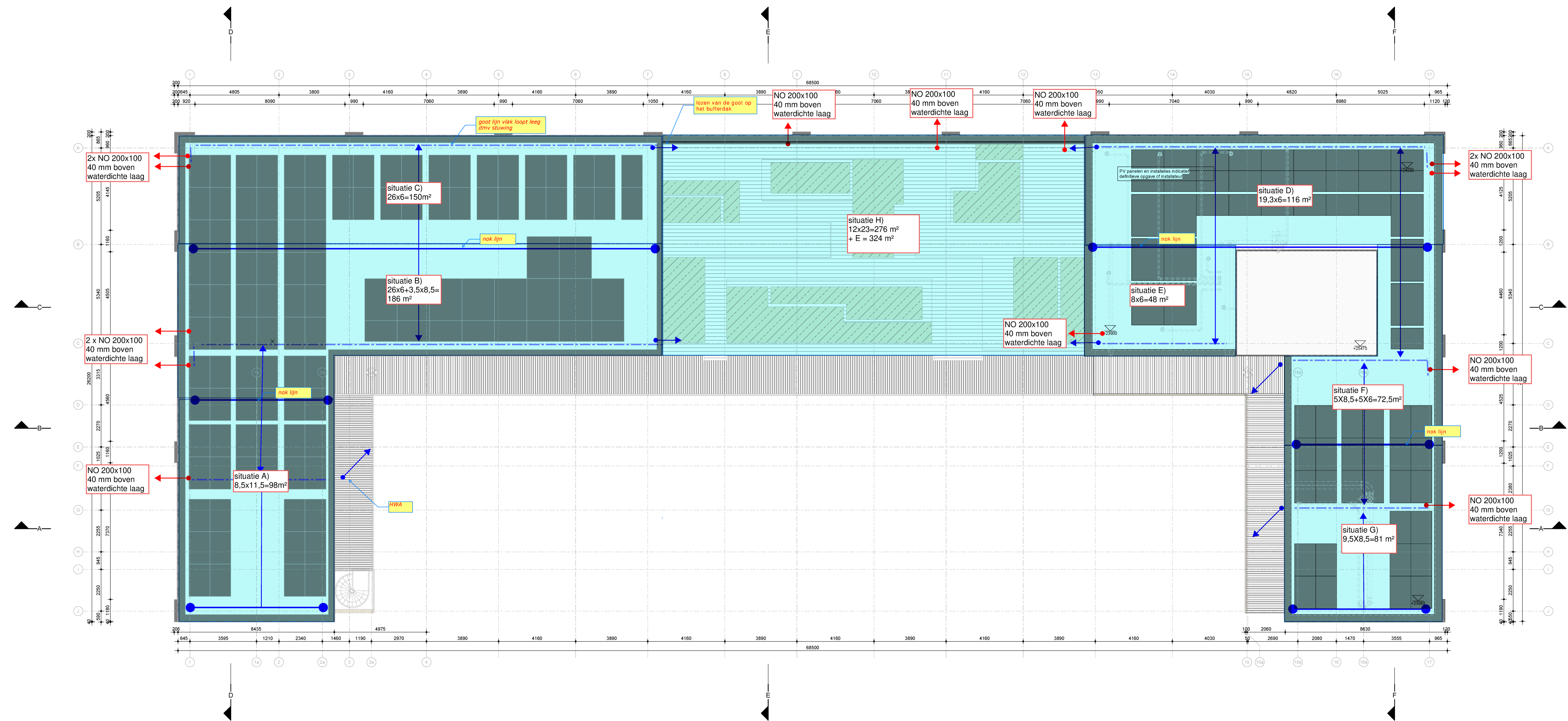

- deur ≥ 850mm doorgang ≥ 2300mm hoogte
- vrijloop deur: deur kan in vluchtrichting ten alle tijden geopend worden
- rooilijn
- schieding 30 minuten WBDBO
- schieding 30 minuten WBDBO en R200 rookwerend
- schieding 30 minuten WBDBO en Ra rookwerend
- schieding 60 minuten WBDBO
- schieding 60 minuten WBDBO en R200 rookwerend
- schieding 60 minuten WBDBO en Ra rookwerend
- rookmeider
- blusleiding
- WKO
- WTW
- WD
- WM
- harborfenster
- hwa
- glazen vouwrand loggia's
- entree
- spiering
- vrijloopdranger
- KZS
- CLT
- prefab beton
- lichte schiedingwand
- isolatie
- glazen kolomfijger

**Lister Buildings**  
 Walpoort 10  
 5211 DK Den Bosch  
 +31 (0) 1348 940

**MEESVISSER**  
 Paul van Vissagenstraat 2d  
 1506BX Amsterdam  
 +31 (0)20 7371742

**WABO**  
 opdrachtgever  
 Lister Development  
 BV  
 werk  
 Koffieabriek  
 fase  
 DO  
 datum  
 28-09-2023  
 schaal  
 1:100  
 formaat  
 A1XL  
 getekend  
 mbr  
 gecontroleerd  
 gewijzigd

207 - zevende verdieping / dak verdieping

## Noodoverstorten conform NEN-EN 1991-1-3+C1:2011/NB:2011

artikel 7.2

Situatie A

afvoergebied	<b>98</b>	m <sup>2</sup>
referentieperiode	<b>50</b>	jr.
regenintensiteit	5,00E-05	m/s

Tabel NB.1

$$Q_h = 0,0049 \text{ m}^3/\text{s}$$

Debiet noodoverlaten van afvoergebied

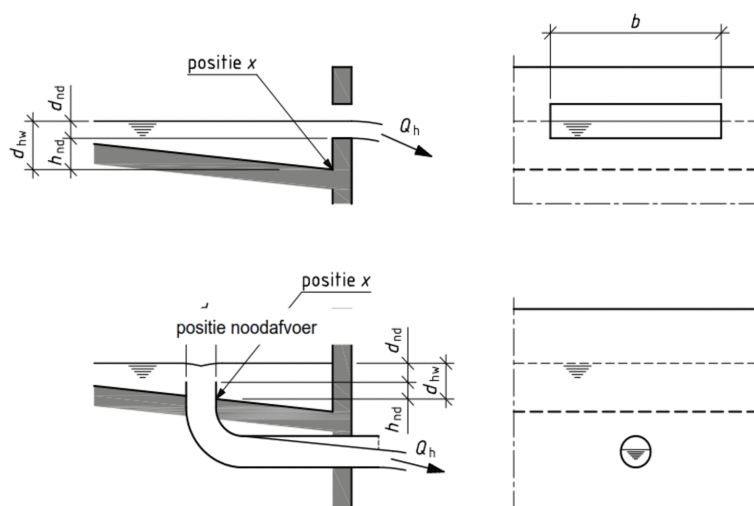

Figuur NB.3 — Waterhoogte  $d_{hw}$  bij een rechte vrije overlaat en een ronde steekafvoer

<b>rechte vrije overlaat</b>			
aantal	<b>1</b>	stuks	
$h_{nd}$ =	<b>40</b>	mm	Hoogte onderzijde noodoverlaat t.o.v. bovenzijde dakbedekking
$b$ =	<b>200</b>	mm	Breedte noodoverlaat
$d_{nd}$ =	60	mm	Waterhoogte boven onderzijde noodafvoer
$d_{hw}$ =	100	mm	Waterhoogte boven bovenzijde dakbedekking
$h_{min}$ =	90	mm	Minimale netto hoogte noodoverlaten
$P_w$ =	<b>1,00</b>	kN/m <sup>2</sup>	Maximale variabele belasting t.g.v. hemelwater op dakvlak

afmeting noodoverlaat **200 x 90 mm<sup>2</sup>**

Minimale netto afmetingen noodoverlaat

## Noodoverstorten conform NEN-EN 1991-1-3+C1:2011/NB:2011

artikel 7.2

Situatie B

afvoergebied	186	m <sup>2</sup>
referentieperiode	50	jr.
regenintensiteit	5,00E-05	m/s

Tabel NB.1

$$Q_h = 0,0093 \text{ m}^3/\text{s}$$

Debiet noodoverlaten van afvoergebied

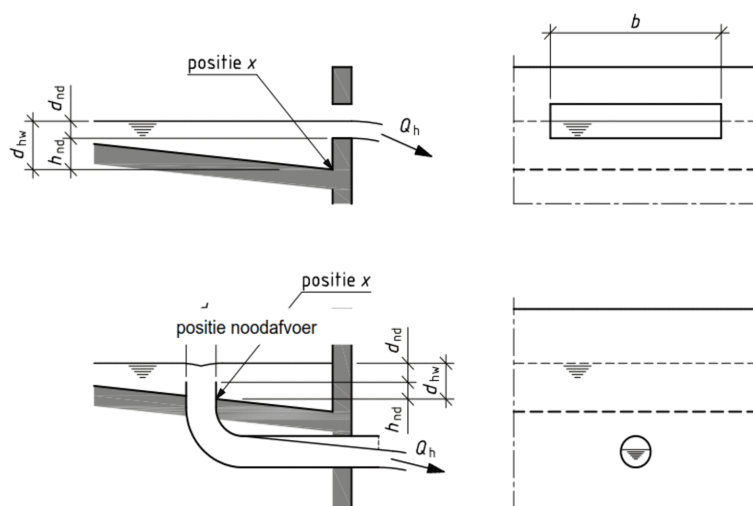

Figuur NB.3 — Waterhoogte  $d_{hw}$  bij een rechte vrije overlaat en een ronde steekafvoer

<b>rechte vrije overlaat</b>			
aantal	2	stuks	
$h_{nd}$ =	40	mm	Hoogte onderzijde noodoverlaat t.o.v. bovenzijde dakbedekking
$b$ =	200	mm	Breedte noodoverlaat
$d_{nd}$ =	50	mm	Waterhoogte boven onderzijde noodafvoer
$d_{hw}$ =	90	mm	Waterhoogte boven bovenzijde dakbedekking
$h_{min}$ =	80	mm	Minimale netto hoogte noodoverlaten
$P_w$ =	0,90	kN/m <sup>2</sup>	Maximale variabele belasting t.g.v. hemelwater op dakvlak

afmetingen noodoverlaten: **200 x 80 mm<sup>2</sup>**

Minimale netto afmetingen noodoverlaat

## Noodoverstorten conform NEN-EN 1991-1-3+C1:2011/NB:2011

artikel 7.2

Situatie C

afvoergebied	<b>150</b>	m <sup>2</sup>
referentieperiode	<b>50</b>	jr.
regenintensiteit	5,00E-05	m/s

Tabel NB.1

$$Q_h = 0,0075 \text{ m}^3/\text{s}$$

Debiet noodoverlaten van afvoergebied

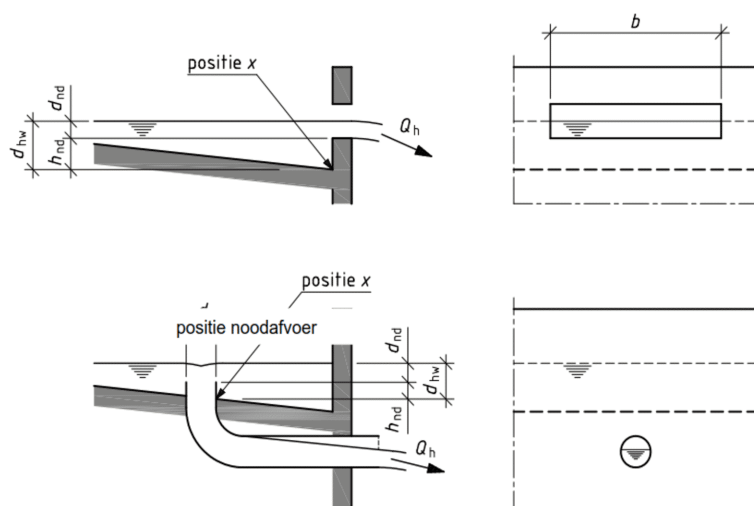

Figuur NB.3 — Waterhoogte  $d_{hw}$  bij een rechte vrije overlaat en een ronde steekafvoer

<b>rechte vrije overlaat</b>			
aantal	<b>2</b>	stuks	
$h_{nd}$	<b>40</b>	mm	Hoogte onderzijde noodoverlaat t.o.v. bovenzijde dakbedekking
$b$	<b>200</b>	mm	Breedte noodoverlaat
$d_{nd}$	40	mm	Waterhoogte boven onderzijde noodafvoer
$d_{hw}$	80	mm	Waterhoogte boven bovenzijde dakbedekking
$h_{min}$	70	mm	Minimale netto hoogte noodoverlaten
$P_w$	<b>0,80</b>	kN/m <sup>2</sup>	Maximale variabele belasting t.g.v. hemelwater op dakvlak

afmetingen noodoverlaten: **200 x 70 mm<sup>2</sup>**

Minimale netto afmetingen noodoverlaat

## Noodoverstorten conform NEN-EN 1991-1-3+C1:2011/NB:2011

artikel 7.2

Situatie D

afvoergebied	<b>116</b>	m <sup>2</sup>
referentieperiode	<b>50</b>	jr.
regenintensiteit	5,00E-05	m/s

Tabel NB.1

$$Q_h = 0,0058 \text{ m}^3/\text{s}$$

Debiet noodoverlaten van afvoergebied

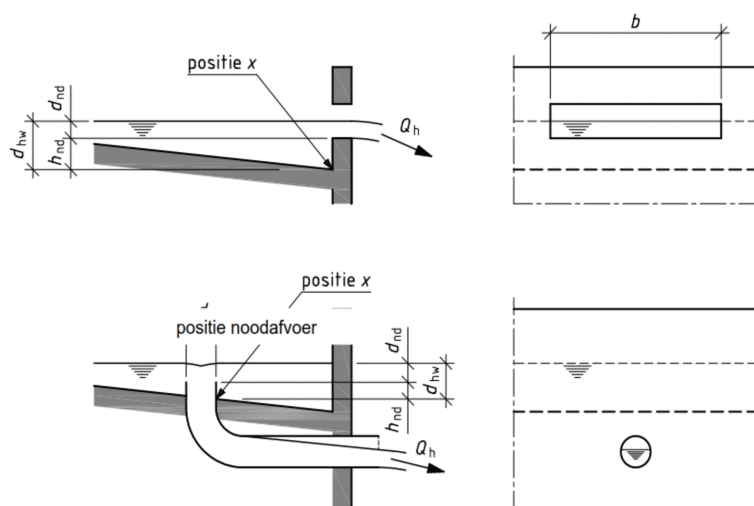

Figuur NB.3 — Waterhoogte  $d_{hw}$  bij een rechte vrije overlaat en een ronde steekafvoer

<b>rechte vrije overlaat</b>			
aantal	<b>2</b>	stuks	
$h_{nd}$	<b>40</b>	mm	Hoogte onderzijde noodoverlaat t.o.v. bovenzijde dakbedekking
$b$	<b>200</b>	mm	Breedte noodoverlaat
$d_{nd}$	40	mm	Waterhoogte boven onderzijde noodafvoer
$d_{hw}$	80	mm	Waterhoogte boven bovenzijde dakbedekking
$h_{min}$	70	mm	Minimale netto hoogte noodoverlaten
$P_w$	<b>0,80</b>	kN/m <sup>2</sup>	Maximale variabele belasting t.g.v. hemelwater op dakvlak

afmetingen noodoverlaten: **200 x 70 mm<sup>2</sup>**

Minimale netto afmetingen noodoverlaat

## Noodoverstorten conform NEN-EN 1991-1-3+C1:2011/NB:2011

artikel 7.2

Situatie E

afvoergebied	<b>48</b>	m <sup>2</sup>
referentieperiode	<b>50</b>	jr.
regenintensiteit	5,00E-05	m/s

Tabel NB.1

$$Q_h = 0,0024 \text{ m}^3/\text{s}$$

Debiet noodoverlaten van afvoergebied

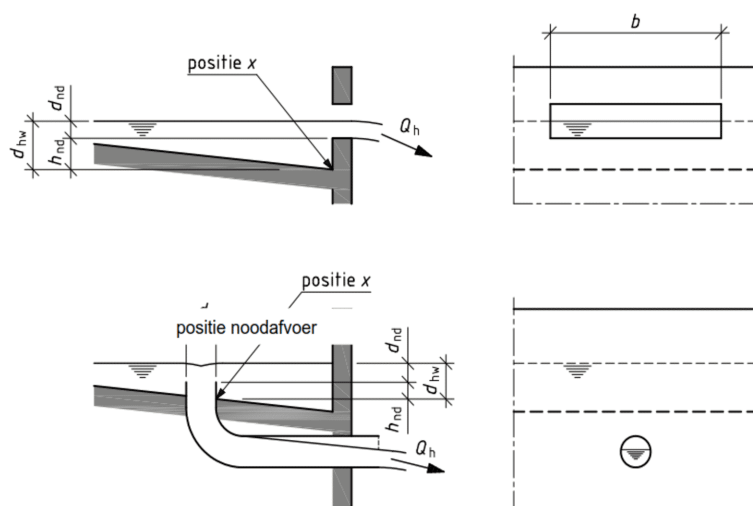

Figuur NB.3 — Waterhoogte  $d_{hw}$  bij een rechte vrije overlaat en een ronde steekafvoer

<b>rechte vrije overlaat</b>			
aantal	<b>1</b>	stuks	
$h_{nd}$ =	<b>40</b>	mm	Hoogte onderzijde noodoverlaat t.o.v. bovenzijde dakbedekking
$b$ =	<b>200</b>	mm	Breedte noodoverlaat
$d_{nd}$ =	40	mm	Waterhoogte boven onderzijde noodafvoer
$d_{hw}$ =	80	mm	Waterhoogte boven bovenzijde dakbedekking
$h_{min}$ =	70	mm	Minimale netto hoogte noodoverlaten
$P_w$ =	<b>0,80</b>	kN/m <sup>2</sup>	Maximale variabele belasting t.g.v. hemelwater op dakvlak

afmeting noodoverlaat **200 x 70 mm<sup>2</sup>**

Minimale netto afmetingen noodoverlaat

## Noodoverstorten conform NEN-EN 1991-1-3+C1:2011/NB:2011

artikel 7.2

Situatie F

afvoergebied	<b>72,5</b>	m <sup>2</sup>
referentieperiode	<b>50</b>	jr.
regenintensiteit	5,00E-05	m/s

Tabel NB.1

$$Q_h = 0,003625 \text{ m}^3/\text{s}$$

Debiet noodoverlaten van afvoergebied

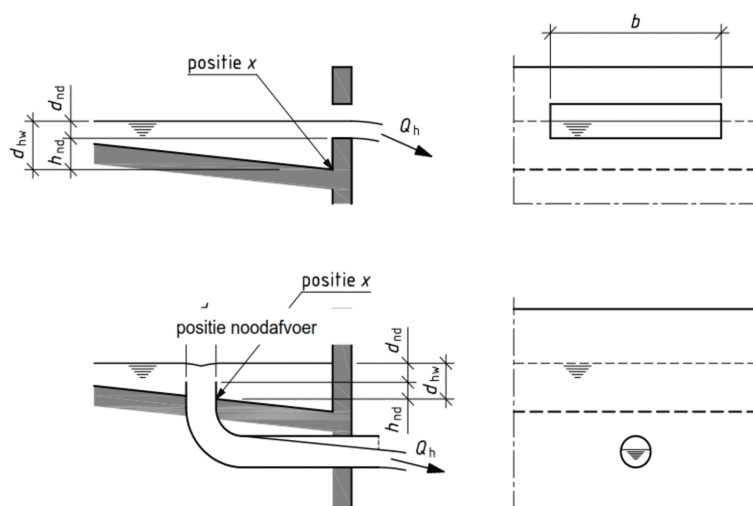

Figuur NB.3 — Waterhoogte  $d_{hw}$  bij een rechte vrije overlaat en een ronde steekafvoer

<b>rechte vrije overlaat</b>			
aantal	<b>1</b>	stuks	
$h_{nd}$ =	<b>40</b>	mm	Hoogte onderzijde noodoverlaat t.o.v. bovenzijde dakbedekking
$b$ =	<b>200</b>	mm	Breedte noodoverlaat
$d_{nd}$ =	50	mm	Waterhoogte boven onderzijde noodafvoer
$d_{hw}$ =	90	mm	Waterhoogte boven bovenzijde dakbedekking
$h_{min}$ =	80	mm	Minimale netto hoogte noodoverlaten
$P_w$ =	<b>0,90</b>	kN/m <sup>2</sup>	Maximale variabele belasting t.g.v. hemelwater op dakvlak

afmeting noodoverlaat **200 x 80 mm<sup>2</sup>**

Minimale netto afmetingen noodoverlaat

## Noodoverstorten conform NEN-EN 1991-1-3+C1:2011/NB:2011

artikel 7.2

Situatie G

afvoergebied	<b>81</b>	m <sup>2</sup>
referentieperiode	<b>50</b>	jr.
regenintensiteit	5,00E-05	m/s

Tabel NB.1

$$Q_h = 0,00405 \text{ m}^3/\text{s}$$

Debiet noodoverlaten van afvoergebied

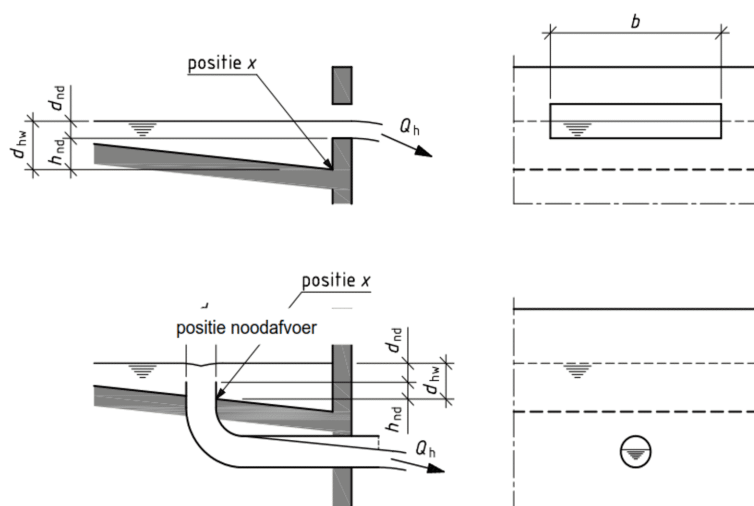

Figuur NB.3 — Waterhoogte  $d_{hw}$  bij een rechte vrije overlaat en een ronde steekafvoer

<b>rechte vrije overlaat</b>			
aantal	<b>1</b>	stuks	
$h_{nd}$ =	<b>40</b>	mm	Hoogte onderzijde noodoverlaat t.o.v. bovenzijde dakbedekking
$b$ =	<b>200</b>	mm	Breedte noodoverlaat
$d_{nd}$ =	60	mm	Waterhoogte boven onderzijde noodafvoer
$d_{hw}$ =	100	mm	Waterhoogte boven bovenzijde dakbedekking
$h_{min}$ =	90	mm	Minimale netto hoogte noodoverlaten
$P_w$ =	<b>1,00</b>	kN/m <sup>2</sup>	Maximale variabele belasting t.g.v. hemelwater op dakvlak

afmeting noodoverlaat **200 x 90 mm<sup>2</sup>**

Minimale netto afmetingen noodoverlaat

■ Datum: 22 februari 2024

■ Project: Koffiefabriek, Joan Muyskenweg  
19, Amsterdam

■ Betreft: Toetsrapport - OV - OLO-8325147

■ Ref.nr.: M-321-139-DO-01

## **Bijlage 4 – Toetsrapport omgevingsvergunning**

## Toetsrapport

Constructieve beoordeling van gegevens/documenten voor het (bouw)project met de volgende gegevens:

Projectlocatie: Joan Muyskenweg 19, Amsterdam

Projectomschrijving: oprichten woongebouw

Aanvraagnummer: OLO-8325147

Toetsnummer - 0

24-1-2024

5.1, 2, d

5.1, 2, i

5.1, 2, d

5.1, 2, i

5.1, 2, d  
5.1, 2, i