

5.1, 2, e
5.1, 2, e

— TITEL
VILLA HERMAN GORTERSTRAAT, AMSTERDAM
WAPENINGSBEREKENING

— DATUM
30 juni 2023

— ONS KENMERK
B3-21038-20230519_rev.1_20230630

— OPGESTELD DOOR
ing 5.1, 2, e

— VRIJGEGEVEN DOOR
ing 5.1, 2, e

— STATUS
Definitief



— Projectgegevens

Projectnaam VILLA HERMAN GORTERSTRAAT, AMSTERDAM

Projectcode 21038

Onderdeel WAPENINGSBEREKENING

Datum 30 JUNI 2023

Opdrachtgever 5.1, 2, e

Architect HofmanDujardin

Revisie beheer

19 MEI 2023 Oorspronkelijk rapport

➤ 30 JUNI 2023 Revisie 1: Verwerken bestaande palen

Laatste constructieve tekeningen in bezit?

Controleer door middel van onderstaande QR-code de laatste tekeningenlijst.



In rapport is gebruik gemaakt van grafische toelichting. De illustraties zijn slechts bedoeld als toelichting op de berekeningen, of als uitgangspunt voor de berekeningen. De illustraties zijn, in verband met de doorontwikkeling van het gebouw, mogelijk niet up-to-date; berekeningsresultaten kunnen daarom afwijken van hetgeen in de illustraties staat afgebeeld. De berekeningen zijn altijd leidend.



Inhoud

1	Inleiding	4
1.1	Projectbeschrijving	4
1.2	Gehanteerde voorschriften en software	4
1.3	Bijbehorende documenten	4
2	Aanpassing palenplan	5
3	Wapening kelder	6
3.1	Milieuklasse en dekking	6
3.2	Keldervloer	6
3.2.1	Stekken	6
3.2.2	Ponscheck	6
3.3	Kelderwanden	7
3.3.1	Wapening stortfase	7
3.3.2	Trekbandwapening	7
3.3.3	Dwarskrachtwapening	8
3.4	Overige wanden	9
4	Detailberekeningen	10
4.1	Wand as D, 1 ^e verd.	10
4.2	Wand as A, 1 ^e verd., tussen as 1-5	11
4.3	Wand as 4', 1 ^e verd., tussen as C-D	12
4.4	Wand as 5, BG, tussen as A-C	13
4.5	Wand as 5, 1 ^e verd., tussen as A-C	13
4.6	Wand as 4, dak, tussen as A-C	14
4.7	Wand as 2, 1 ^e verd. en dak, tussen as A-B	14
4.8	Wand as 2, 1 ^e verd. en dak, tussen as B-D	15
4.9	Kolom as 4', kelder, tussen as B-C	16
5	Bijlagen	17
5.1	Bijlage 1 – Vloerstrook kelder as C	18
5.2	Bijlage 2 – Uitvoer Technosoft Balkroosters	19
5.3	Bijlage 3 – Wand as D, 1 ^e verd. TS Liggers	20
5.4	Bijlage 4 – Wand as A, 1 ^e verd., tussen as 1-5	21
5.5	Bijlage 5 – Wand as 4', 1 ^e verd., tussen as C-D	22
5.6	Bijlage 6 – Wand as 5, BG, tussen as A-C	23
5.7	Bijlage 7 – Wand as 5, 1 ^e verd., tussen as A-C	24
5.8	Bijlage 8 – Wand as 4, dak, tussen as A-C	25
5.9	Bijlage 9 – Wand as 2, 1 ^e verd. en dak, tussen as A-B	26
5.10	Bijlage 10 – Wand as 2, 1 ^e verd. en dak, tussen as B-D	27
5.11	Bijlage 11 – Kolom as 4', kelder, tussen as B-C	28
5.12	Bijlage 12 – Principe wandwapening TS Kolomwapening	29
5.13	Bijlage 13 – Keldervloer ponscheck	30



— 1 Inleiding

1.1 PROJECTBESCHRIJVING

Dit rapport omvat de detailberekening van de wapening van de vloeren, wanden en balken van het project villa Herman Gorterstraat te Amsterdam. In deze berekening zijn de berekeningsresultaten uit de gewichtsberekening van de laagbouw, B2-21038-20221003 d.d. 03 oktober 2022, opgesteld door **5.1, 2, e** 5.1, 2, e gehanteerd.

Door de aanwezigheid van bestaande palen welke na sloop ingemeten zijn, zijn een aantal paalposities aangepast en is de wapening waar nodig herzien

1.2 GEHANTEERDE VOORSCHRIFTEN EN SOFTWARE

De volgende normen (inclusief nationale bijlage) zijn gebruikt:

NEN-EN 1990	Grondslagen van het constructief ontwerp
NEN-EN 1991-1-1	Algemene belastingen voor gebouwen
NEN-EN 1992-1-1	Ontwerp en berekening betonconstructies: algemene regels en regels voor gebouwen

Scia Engineer 21
Technosoft Balkroosters V6
Technosoft Liggers V6
Technosoft Kolomwapening V6
QEC-rekensheets 2023

1.3 BIJBEHORENDE DOCUMENTEN

- Constructieve tekeningen BREED ID conform tekeningenlijst TL1-21038
- Gewichtsberekening, B2-21038-20221003 d.d. 03 oktober 2022, opgesteld door BREED ID.



2 Aanpassing palenplan

Teneinde een minimale tussenafstand van 500 mm tussen de bestaande en de nieuwe palen te verkrijgen zijn enkele palen verschoven en is op as A een paal toegevoegd. De steunpunten zijn aangepast in het balkroostermodel waarna de wapening opnieuw berekend is. Tevens is op verzoek van de paalleverancier een ander paalsysteem gekozen, te weten een Waalschroefinjectiepaal. Daar waar de reeds berekende wapening niet meer voldeed is deze aangepast. De wapening wordt in het volgende hoofdstuk berekend. In onderstaande afbeelding zijn de UGT paalbelastingen aangegeven. Conform het advies van Hektec zijn deze allen opneembaar.

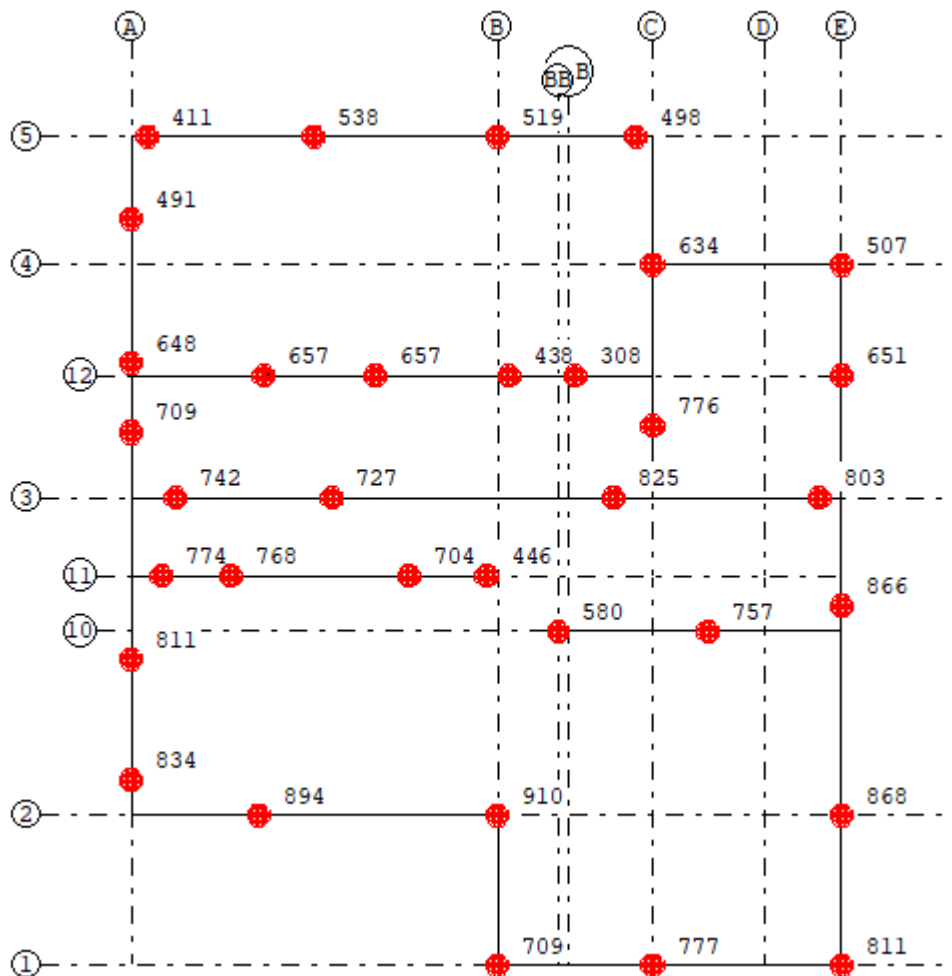

UGT paalreacties



3 Wapening kelder

3.1 MILIEUKLASSE EN DEKKING

- Keldervloer: o/b XC3, dekking min. 30 mm
- Kelderwand: bi XC3, dekking min. 25 mm
- Kelderwand: bu XC4, XF1, dekking min. 30 mm
- Overige wanden: XC1, dekking min. 25 mm
- Balk op dak: XC1, dekking min. 25 mm

3.2 KELDERVLOER

Voor de kelder is de maatgevende strook berekend, inclusief kelderwanden, waarop de wapening van de hele kelder bepaald wordt. De maatgevende strook bevindt zich t.p.v. as C. Zie Bijlage 1 – Vloerstrook kelder as C.

Toepassen vloerwapening: o/b Ø12-100 in beide richtingen
 Rondom hrsp Ø10-100 toepassen

3.2.1 STEKKEN

O.b.v. de vloerstrookberekening de volgende stekken toepassen:
 bi Ø10-150
 bu Ø12-100

3.2.2 PONSHECK

De WSI-paal wordt verankerd in de vloer d.m.v. een trekring. De verankering in de keldervloer is opnieuw getoetst op afschuiving met Technosoft Construct. Er is geen extra wapening benodigd, zie Bijlage 13 – Keldervloer ponscheck. Om voldoende nuttige hoogte over te houden mag de onderkant van de trekring maximaal 50 mm onder de bovenkant van de keldervloer zitten. Dit staat aangegeven op het palenplan.

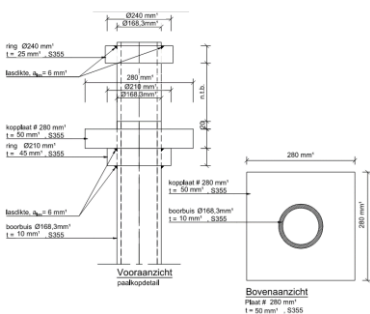

3.3

KELDERWANDEN

De kelderwanden worden berekend m.b.v. Technosoft Balkroosters. Voor het berekeningsrapport, zie Bijlage 2 – Uitvoer Technosoft Balkroosters.

T.o.v. een eerder rapport uit de vorige fase is er een kleine aanpassing geweest op de geometrie in de wand op as 3'. Dit is aangepast in het Technosoft Balkroosters-model. De resultaten kunnen dus afwijken van het eerdere rapport.

3.3.1 WAPENING STORTFASE

$$M = 1/8ql^2$$

$$q = (0,25 \cdot 2,9 + 0,3 \cdot 1) \cdot 25 = 26,6 \text{ kN/m}$$

$$L = 3,4 \text{ m}$$

$$M = 1/8 \cdot 26,6 \cdot 3,4 = 37,0 \text{ kNm}$$

$$A_{s,req} = 37,0 / 0,435 / (0,8 \cdot 0,3) = 355 \text{ mm}^2 < 785 \text{ mm}^2$$

Geen extra wapening benodigd.

3.3.2 TREKBANDWAPENING

➤ Wand as A:

Volgens TS balkroosters

$$A_{s;onder} = 858 \text{ mm}^2 \rightarrow \text{pas toe in keldervloer o/b } 4\text{Ø}12 = 905 \text{ mm}^2$$

$$A_{s;boven} = 1564 \text{ mm}^2 \rightarrow \text{pas toe in wand v/a } \text{Ø}10\text{-}150 + 5\text{Ø}12\text{-}150 = 1654 \text{ mm}^2$$

➤ Wand as C:

Volgens TS balkroosters

$$A_{s;onder} = 858 \text{ mm}^2 \rightarrow \text{pas toe in keldervloer o/b } 4\text{Ø}12 = 905 \text{ mm}^2$$

$$A_{s;boven} = 858 \text{ mm}^2 \rightarrow \text{pas toe in wand v/a } \text{Ø}10\text{-}150 + 3\text{Ø}12\text{-}150 = 1202 \text{ mm}^2$$

➤ Wand as 2 en as E:

Volgens TS balkroosters $A_s = 934 \text{ mm}^2 \rightarrow \text{pas toe in keldervloer o/b } 4\text{Ø}12 = 905 \text{ mm}^2$ i.c.m. $1\text{Ø}12$ uit de vloer = 1018 mm^2

Wand as 3:

Volgens TS balkroosters

$$A_{s;onder} = 1288 \text{ mm}^2 \rightarrow \text{pas toe in keldervloer o/b } 6\text{Ø}12 = 1358 \text{ mm}^2$$

➤ $A_{s;boven} = 2472 \text{ mm}^2 \rightarrow \text{pas toe in wand v/a } \text{Ø}10\text{-}150 + 5\text{Ø}16\text{-}150 = 2534 \text{ mm}^2$

➤ $A_{s;boven} = 858 \text{ mm}^2 \rightarrow \text{pas toe in wand v/a } \text{Ø}10\text{-}150 + 3\text{Ø}12\text{-}150 = 1202 \text{ mm}^2$

➤ $A_{s;boven} = 536 \text{ mm}^2 \rightarrow \text{pas toe in wand v/a } \text{Ø}10\text{-}150 + 3\text{Ø}12\text{-}150 = 1202 \text{ mm}^2$



ONDERWERP: VILLA HERMAN GORTERSTRAAT, AMSTERDAM

- Wand as 3':
Volgens TS balkroosters
As;onder = 858 mm² -> pas toe in keldervloer o/b 6Ø12 = 1358 mm²
As;boven = 858 mm² -> pas toe in wand v/a Ø10-150+5Ø12-150 = 1654 mm²

- Wand as 3'':
Volgens TS balkroosters
Deel balk:
As;onder = 1528 mm² -> pas toe in balk 5Ø20 = 1571 mm²

- Overige wanden:
Volgens TS balkroosters As = 858 mm² -> pas toe in keldervloer o/b 4Ø12 = 905 mm²

3.3.3 DWARSKRACHTWAPENING

Kelderwanden:

Volgens TS balkroosters As;max = 219 mm²/m

Berekende verticale wapening uit waterdruk As = 1048 mm²

-> pas toe in kelderwand: buitenzijde Ø10-75 = 1048 mm²

binnenzijde Ø10-150 = 524 mm²

Totaal: 1131+524 > 1084+219, voldoet

- Wand as A: As;dwars = 1213 mm²/m
Berekende verticale wapening uit waterdruk As = 1048 mm²
-> pas toe in kelderwand binnen- en buitenzijde:
 $1213+1048+524 / 2 = 1393 \text{ mm}^2/\text{m}$ -> v/a Ø10-150+12-100 = 1655 mm²

- Wand as C: As;dwars = 576 mm²/m
Berekende verticale wapening uit waterdruk As = 1048 mm²
-> pas toe in kelderwand: buitenzijde Ø10-75 = 1048 mm²
binnenzijde Ø10-150 = 524 mm²
Totaal: 1131+524 > 1084+576, voldoet

- Wand as 3: As;dwars = 1504 mm²/m
Berekende verticale wapening uit waterdruk As = 1048 mm²
-> pas toe in kelderwand binnen- en buitenzijde:
 $1506+1048+524 / 2 = 1539 \text{ mm}^2/\text{m}$ -> v/a Ø10-150+12-100 = 1655 mm²

- Wand as 3': As;dwars = 552 mm²/m
-> pas toe in kelderwand voor-/achterzijde: Ø10-150



- Wand as 3'': $A_{s;dwars} = 1029 \text{ mm}^2/\text{m}$
-> pas toe in balk bgls 8-150 (4sn)

Overige wanden volgens uitvoer TS balkroosters.

3.4

OVERIGE WANDEN

De drukwapening van de overige wanden is berekend met een principeberekening in Technosoft Kolomwapening, zie Bijlage 12 – Principe wandwapening TS Kolomwapening



4 Detailberekeningen

4.1

WAND AS D, 1^E VERD.

Wapening volgens Technosoft Liggers-berekening, zie Bijlage 3 – Wand as D, 1^e verd. TS Liggers. In onderstaande tabel zijn de belastingen weergegeven.

wand as D																
q1 :	cat.	G _k	Q _k	ψ	factor lengte	breedte	lengte	aantal	G _{rep}	Q _{rep}	Q _{rep}	6.10a	6.10b	stabiliteit / opdrijven		
														1,35 G + 1,50 * Qcomb	1,20 G + 1,50 Qact+comb	1,20 G + 1,50 * Qcomb
		kar. [kNm ²]	kar. factor [kNm ²]	comb.w	-	[m]	[m]	-	rep. perm.	rep. comb. (y _d)	rep. extr+comb(ψ _d)	1,35 G + 1,50 * Qcomb	1,20 G + 1,50 Qact+comb	1,20 G + 1,50 * Qcomb	0,90 G 1,50 * Qgunstig	
Dak	H	8,05	1,00		1,00	1,00	1,00	1	8,05			10,9	9,7	9,7	7,2	
dakrand; beton b x h = 250 x 300 mm; bak		2,58			1,00	1,00	1,00	1	2,58			3,5	3,1	3,1	2,3	
Verdiepingsvloer en begane grond	A	8,05	2,55	0,40	1,00	1,00	1,00	1	8,01	1,01	2,54	12,3	13,4	11,1	7,2	
Terras	A	8,06	2,50	0,40	1,00	1,00	0,70	1	5,64	0,70	1,75	8,7	9,4	7,8	5,1	
gevel; 100mm bakst; 250mm beton		8,25			1,00	3,05	1,00	1	25,16			34,0	30,2	30,2	22,6	
q 1 kN/m'									49,4	1,7	4,3	69,3	65,8	61,9	44,5	
lengte van de q-last: 1,390 [m]									UGT / Frequente aanw		1,34	1,27	totaal Qd [kN]:		96	91
q2 :	cat.	G _k	Q _k	ψ	factor lengte	breedte	lengte	aantal	G _{rep}	Q _{rep}	Q _{rep}	6.10a	6.10b	stabiliteit / opdrijven		
														1,35 G + 1,50 * Qcomb	1,20 G + 1,50 Qact+comb	1,20 G + 1,50 * Qcomb
		kar. [kNm ²]	kar. factor [kNm ²]	comb.w	-	[m]	[m]	-	rep. perm.	rep. comb. (y _d)	rep. extr+comb(ψ _d)	1,35 G + 1,50 * Qcomb	1,20 G + 1,50 Qact+comb	1,20 G + 1,50 * Qcomb	0,90 G 1,50 * Qgunstig	
Dak	H	8,05	1,00		1,00	1,00	1,00	1	8,05		1,00	10,9	11,2	9,7	7,2	
Dak balklaag 5500+	H	2,30	1,00		1,00	1,00	0,70	1	1,61		0,70	2,2	3,0	1,9	1,4	
gevel; 100mm bakst; 250mm beton		8,25			1,00	2,24	1,00	1	18,44			24,9	22,1	22,1	16,6	
dakrand; beton b x h = 250 x 300 mm; bak		2,58			1,00	1,00	1,00	1	2,58			3,5	3,1	3,1	2,3	
q 2 kN/m'									30,7		1,7	41,4	39,4	36,8	27,6	
lengte van de q-last: 2,400 [m]									UGT / Frequente aanw		1,35	1,28	totaal Qd [kN]:		99	94
q3 :	cat.	G _k	Q _k	ψ	factor lengte	breedte	lengte	aantal	G _{rep}	Q _{rep}	Q _{rep}	6.10a	6.10b	stabiliteit / opdrijven		
														1,35 G + 1,50 * Qcomb	1,20 G + 1,50 Qact+comb	1,20 G + 1,50 * Qcomb
		kar. [kNm ²]	kar. factor [kNm ²]	comb.w	-	[m]	[m]	-	rep. perm.	rep. comb. (y _d)	rep. extr+comb(ψ _d)	1,35 G + 1,50 * Qcomb	1,20 G + 1,50 Qact+comb	1,20 G + 1,50 * Qcomb	0,90 G 1,50 * Qgunstig	
Dak	H	8,05	1,00		1,00	1,00	1,00	1	8,05			10,9	11,2	9,7	7,2	
Verdiepingsvloer en begane grond	A	8,05	2,55	0,40	1,00	1,00	1,00	1	8,05	1,02	1,02	12,4	11,2	11,2	7,2	
Dak balklaag 5500+	H	2,30	1,00		1,00	1,00	0,70	1	1,61		0,70	2,2	3,0	1,9	1,4	
gevel; 100mm bakst; 250mm beton		8,25			1,00	2,24	1,00	1	18,44			24,9	22,1	22,1	16,6	
dakrand; beton b x h = 250 x 300 mm; bak		2,58			1,00	1,00	1,00	1	2,58			3,5	3,1	3,1	2,3	
q 3 kN/m'									38,7	1,0	2,7	53,8	50,5	48,0	34,9	
lengte van de q-last: 1,740 [m]									UGT / Frequente aanw		1,36	1,28	totaal Qd [kN]:		94	88



ONDERWERP: VILLA HERMAN GORTERSTRAAT, AMSTERDAM

4.2

WAND AS A, 1^E VERD., TUSSEN AS 1-5

Ter hoogte van de 1^e verdiepingvloer is er een strook berekend van 610 mm hoog, de minimale hoogte van de wand. Zie Bijlage 4 – Wand as A, 1^e verd., tussen as 1-5. De belastingen zijn weergegeven in onderstaande tabel.

wand as A															
q1 :	cat.	G _k	Q _k	ψ	factor lengte	breedte	lengte	aantal	G _{rep}	Q _{rep}	Q _{rep}	6.10a	6.10b	stabiliteit / opdrijven	
		kar. [kNm ²]	kar. factor [kNm ²]	comb.w	-	[m]	[m]	-	rep. perm.	rep. comb. (y _d)	rep. extr+comb(ψ _d)	1,35 G + 1,50 * Qcomb	1,20 G + 1,50 Qextr+comb	1,20 G + 1,50 * Qcomb	0,90 G 1,50 * Qgunstig
Verdiepingvloer en begane grond	A	8,05	2,55	0,40	1,00	1,00	1,00	1	8,05	1,02	2,55	12,4	13,5	11,2	7,2
gevel; 100mm bakst; 250mm beton		8,25			1,00	3,00	1,00	1	24,75			33,4	29,7	29,7	22,3
wand; 250mm beton		6,25			1,00	3,00	1,00	1	18,75			25,3	22,5	22,5	16,9
dakrand; beton b x h = 250 x 300 mm; bak		2,58			1,00	1,00	1,00	1	2,58			3,5	3,1	3,1	2,3
q 1 kNm/m									54,1	1,0	2,6	74,6	68,8	66,5	48,7
lengte van de q-last: [m]									UGT / Frequente aanw totaal Qd [kN]: 1,35 1,24						
q2 :	cat.	G _k	Q _k	ψ	factor lengte	breedte	lengte	aantal	G _{rep}	Q _{rep}	Q _{rep}	6.10a	6.10b	stabiliteit / opdrijven	
		kar. [kNm ²]	kar. factor [kNm ²]	comb.w	-	[m]	[m]	-	rep. perm.	rep. comb. (y _d)	rep. extr+comb(ψ _d)	1,35 G + 1,50 * Qcomb	1,20 G + 1,50 Qextr+comb	1,20 G + 1,50 * Qcomb	0,90 G 1,50 * Qgunstig
Verdiepingvloer en begane grond	A	8,05	2,55	0,40	1,00	1,00	1,00	1	8,05	1,02	2,55	12,4	13,5	11,2	7,2
gevel; 100mm bakst; 250mm beton		8,25			1,00	3,05	1,00	1	25,16			34,0	30,2	30,2	22,6
wand; 250mm beton		6,25			1,00	1,55	1,00	1	9,69			13,1	11,6	11,6	8,7
dakrand; beton b x h = 250 x 300 mm; bak		2,58			1,00	1,00	1,00	1	2,58			3,5	3,1	3,1	2,3
q 2 kNm/m									45,5	1,0	2,6	62,9	58,4	56,1	40,9
lengte van de q-last: [m]									UGT / Frequente aanw totaal Qd [kN]: 1,35 1,25						
q3 :	cat.	G _k	Q _k	ψ	factor lengte	breedte	lengte	aantal	G _{rep}	Q _{rep}	Q _{rep}	6.10a	6.10b	stabiliteit / opdrijven	
		kar. [kNm ²]	kar. factor [kNm ²]	comb.w	-	[m]	[m]	-	rep. perm.	rep. comb. (y _d)	rep. extr+comb(ψ _d)	1,35 G + 1,50 * Qcomb	1,20 G + 1,50 Qextr+comb	1,20 G + 1,50 * Qcomb	0,90 G 1,50 * Qgunstig
Verdiepingvloer en begane grond	A	8,05	2,55	0,40	1,00	1,00	1,00	1	8,05	1,02	2,55	12,4	13,5	11,2	7,2
gevel; 100mm bakst; 250mm beton		8,25			1,00	0,60	1,00	1	4,95			6,7	5,9	5,9	4,5
wand; 250mm beton		6,25			1,00	0,60	1,00	1	3,75			5,1	4,5	4,5	3,4
dakrand; beton b x h = 250 x 300 mm; bak		2,58			1,00	1,00	1,00	1	2,58			3,5	3,1	3,1	2,3
q 3 kNm/m									19,3	1,0	2,6	27,6	27,0	24,7	17,4
lengte van de q-last: [m]									UGT / Frequente aanw totaal Qd [kN]: 1,34 1,31						
F1 :	cat.	G _k	Q _k	ψ	factor lengte	breedte	lengte	aantal	G _{rep}	Q _{rep}	Q _{rep}	6.10a	6.10b	stabiliteit / opdrijven	
		kar. [kNm ²]	kar. factor [kNm ²]	comb.w	-	[m]	[m]	-	rep. perm.	rep. comb. (y _d)	rep. extr+comb(ψ _d)	1,35 G + 1,50 * Qcomb	1,20 G + 1,50 Qextr+comb	1,20 G + 1,50 * Qcomb	0,90 G 1,50 * Qgunstig
Reactiekracht balkberekening		99,00	14,00	1,00	1,00	1,00	1,00	1	99,00	14,00	14,00	154,7	139,8	139,8	89,1
F 1 kN									99,0	14,0	14,0	154,7	139,8	139,8	89,1
afstand tot begin schema: [m]									UGT / Frequente aanw #####						

ONDERWERP: VILLA HERMAN GORTERSTRAAT, AMSTERDAM

4.3

WAND AS 4', 1^E VERD., TUSSEN AS C-D

Wapening volgens berekening Technosoft Liggers, zie Bijlage 5 – Wand as 4', 1^e verd., tussen as C-D. In onderstaande tabel zijn de belastingen weergegeven.

Wand as 4'															
q1 :	cat.	G _k	Q _k	ψ	factor lengte	breedte	lengte	aantal	G _{rep}	Q _{rep}	Q _{rep}	6.10a	6.10b	stabiliteit / opdrijven	
		kar. [kNm ²]	kar. factor [kNm ²]	comb.w	-	[m]	[m]	-	rep. perm.	rep. comb. (y ₀)	rep. extra+comb(ψ ₀)	1,35 G + 1,50 * Qcomb	1,20 G + 1,50 Q _{ext} +comb	1,20 G + 1,50 * Q _{comb}	0,90 G 1,50 * Q _{gruut}
wand; 250mm beton		6,25			1,00	3,05	1,00	1	19,06			25,7	22,9	22,9	17,2
gevel; 100mm bakst; 250mm beton		8,25			1,00	3,05	1,00	1	25,16			34,0	30,2	30,2	22,6
q 1 kN/m'									44,2			59,7	53,1	53,1	39,8
lengte van de q-last: [m]									UGT / Frequente aanw totaal Qd [kN]:			1,35	1,20		

q2 :	cat.	G _k	Q _k	ψ	factor lengte	breedte	lengte	aantal	G _{rep}	Q _{rep}	Q _{rep}	6.10a	6.10b	stabiliteit / opdrijven	
		kar. [kNm ²]	kar. factor [kNm ²]	comb.w	-	[m]	[m]	-	rep. perm.	rep. comb. (y ₀)	rep. extra+comb(ψ ₀)	1,35 G + 1,50 * Qcomb	1,20 G + 1,50 Q _{ext} +comb	1,20 G + 1,50 * Q _{comb}	0,90 G 1,50 * Q _{gruut}
wand; 250mm beton		6,25			1,00	1,10	1,00	1	6,88			9,3	8,3	8,3	6,2
gevel; 100mm bakst; 250mm beton		8,25			1,00	1,10	1,00	1	9,08			12,3	10,9	10,9	8,2
q 2 kN/m'									16,0			21,5	19,1	19,1	14,4
lengte van de q-last: [m]									UGT / Frequente aanw totaal Qd [kN]:			1,35	1,20		

F1 :	cat.	G _k	Q _k	ψ	factor lengte	breedte	lengte	aantal	G _{rep}	Q _{rep}	Q _{rep}	6.10a	6.10b	stabiliteit / opdrijven	
		kar. [kNm ²]	kar. factor [kNm ²]	comb.w	-	[m]	[m]	-	rep. perm.	rep. comb. (y ₀)	rep. extra+comb(ψ ₀)	1,35 G + 1,50 * Qcomb	1,20 G + 1,50 Q _{ext} +comb	1,20 G + 1,50 * Q _{comb}	0,90 G 1,50 * Q _{gruut}
Dak	H	8,05	1,00		0,25	1,74	2,00	1	7,00		0,87	9,5	9,7	8,4	6,3
Verdiepingsvloer en begane grond	A	8,05	2,55	0,40	0,25	1,74	2,00	1	7,00	0,89	0,89	10,8	9,7	9,7	6,3
Dak balklaag 5500+	H	2,30	1,00		0,25	1,74	2,00	1	2,00		0,87	2,7	3,7	2,4	1,8
wand; 250mm beton		6,25			0,50	2,00	1,00	1	6,25			8,4	7,5	7,5	5,6
gevel; 100mm bakst; 250mm beton		8,25			0,50	2,00	1,00	1	8,25			11,1	9,9	9,9	7,4
F 1 [kN]									30,5	0,9	2,6	42,5	40,6	37,9	27,5
afstand tot begin schema: [m]									UGT / Frequente aanw			1,36	1,30		



ONDERWERP: VILLA HERMAN GORTERSTRAAT, AMSTERDAM

4.4

WAND AS 5, BG, TUSSEN AS A-C

Wapening volgens berekening Technosoft Liggers, zie Bijlage 6 – Wand as 5, BG, tussen as A-C. De belastingen zijn weergegeven in onderstaande tabel.

Wand as 5, BG, A-C																
q1 :	cat.	G _k	Q _k	ψ	factor lengte	breedte	lengte	aantal	G _{rep}	Q _{rep}	Q _{rep}	6.10a	6.10b	stabiliteit / opdrijven		
		kar. [kNm ²]	kar. factor [kNm ²]	comb.w	-	[m]	[m]	-	rep. perm.	rep. comb. (y ₀)	rep. extra+comb (y ₀)	1,35 G + 1,50 * Qcomb	1,20 G + 1,50 Qeet+comb	1,20 G + 1,50 * Qcomb	0,90 G 1,50 * Qgunstig	
Terras	A	8,06	2,50	0,40	1,00	1,00	3,25	1	26,15	3,25	8,11	40,2	43,6	36,3	23,5	
Verdiepingsvloer en begane grond	A	8,05	2,55	0,40	1,00	1,00	3,25	1	26,12	3,31	8,27	40,2	43,8	36,3	23,5	
gevel; 100mm bakst; 250mm beton		8,25			1,00	3,44	1,00	1	28,38			38,3	34,1	34,1	25,5	
HSB; betimm.; houten bi.bl.		1,00			0,65	3,00	1,00	1	1,95			2,6	2,3	2,3	1,8	
dakrand; beton b x h = 250 x 300 mm; bak		2,58			1,00		1,00	1	2,58			3,5	3,1	3,1	2,3	
q 1 kNm ²									85,2	6,6	16,4	124,8	126,8	112,1	76,7	
lengte van de q-last: 1,130 [m]									UGT / Frequente aanw		1,34	1,36	totaal Qd [kN]:		141	143

F1 :	cat.	G _k	Q _k	ψ	factor lengte	breedte	lengte	aantal	G _{rep}	Q _{rep}	Q _{rep}	6.10a	6.10b	stabiliteit / opdrijven	
		kar. [kNm ²]	kar. factor [kNm ²]	comb.w	-	[m]	[m]	-	rep. perm.	rep. comb. (y ₀)	rep. extra+comb (y ₀)	1,35 G + 1,50 * Qcomb	1,20 G + 1,50 Qeet+comb	1,20 G + 1,50 * Qcomb	0,90 G 1,50 * Qgunstig
Terras	A	8,06	2,50	0,40	1,00	1,60	3,25	1	41,85	5,19	12,98	64,3	69,7	58,0	37,7
pui; pui 100%		1,00			0,65	1,60	3,00	1	3,12			4,2	3,7	3,7	2,8
dakrand; beton b x h = 250 x 300 mm; bak		2,58			1,00		1,60	1	4,12			5,6	4,9	4,9	3,7
F 1 [kN]									49,1	5,2	13,0	74,1	78,4	66,7	44,2
afstand tot begin schema: [m]									UGT / Frequente aanw		1,33	1,41			

q2 :	cat.	G _k	Q _k	ψ	factor lengte	breedte	lengte	aantal	G _{rep}	Q _{rep}	Q _{rep}	6.10a	6.10b	stabiliteit / opdrijven		
		kar. [kNm ²]	kar. factor [kNm ²]	comb.w	-	[m]	[m]	-	rep. perm.	rep. comb. (y ₀)	rep. extra+comb (y ₀)	1,35 G + 1,50 * Qcomb	1,20 G + 1,50 Qeet+comb	1,20 G + 1,50 * Qcomb	0,90 G 1,50 * Qgunstig	
Verdiepingsvloer en begane grond	A	8,05	2,55	0,40	1,00	1,00	2,20	1	17,71	2,24	5,61	27,3	29,7	24,6	15,9	
pui; pui 100%		1,00			1,00	3,44	1,00	1	3,44			4,6	4,1	4,1	3,1	
q 2 kNm ²									21,2	2,2	5,6	31,9	33,8	28,7	19,0	
lengte van de q-last: 1,000 [m]									UGT / Frequente aanw		1,33	1,41	totaal Qd [kN]:		32	34

4.5

WAND AS 5, 1^E VERD., TUSSEN AS A-C

Wapening volgens Technosoft Liggers-berekening, zie Bijlage 7 – Wand as 5, 1^e verd., tussen as A-C. In onderstaande tabel is de belasting weergegeven.

Wand as 5, 1e verd, A-C															
q1 :	cat.	G _k	Q _k	ψ	factor lengte	breedte	lengte	aantal	G _{rep}	Q _{rep}	Q _{rep}	6.10a	6.10b	stabiliteit / opdrijven	
		kar. [kNm ²]	kar. factor [kNm ²]	comb.w	-	[m]	[m]	-	rep. perm.	rep. comb. (y ₀)	rep. extra+comb (y ₀)	1,35 G + 1,50 * Qcomb	1,20 G + 1,50 Qeet+comb	1,20 G + 1,50 * Qcomb	0,90 G 1,50 * Qgunstig
Dak	H	8,05	1,00		0,50	1,00	6,30	1	25,36		3,15	34,2	35,2	30,4	22,8
q 1 kNm ²									25,4		3,2	34,2	35,2	30,4	22,8
lengte van de q-last: [m]									UGT / Frequente aanw		1,35	1,39	totaal Qd [kN]:		



4.6

WAND AS 4, DAK, TUSSEN AS A-C

Wapening volgens Technosoft Liggers-berekening en balk voorzien van 30 mm toog, zie Bijlage 8 – Wand as 4, dak, tussen as A-C.

Balk as 4, dak, A-C															
q1 :	cat.	G _k	Q _k	ψ ₀	factor lengte	breedte	lengte	aantal	G _{rep}	Q _{rep}	Q _{rep}	6.10a	6.10b	stabiliteit / opdrijven	
		kar. [kN/m ²]	kar. factor [kN/m ²]	comb.w	-	[m]	[m]	-	rep. perm.	rep. comb. (y _d)	rep. extr+comb(ψ _d)	1,35 G + 1,50 * Qcomb	1,20 G + 1,50 Qextr+comb	1,20 G + 1,50 * Qcomb	0,90 G 1,50 * QgurestG
Dak	H	8,05	1,00		0,50	1,00	3,60	1	14,49	1,80		19,6	20,1	17,4	13,0
						q 1	kN/m		14,5	1,8		19,6	20,1	17,4	13,0

De balk wordt gedeeltelijk ingeklemd in de wanden op assen A en C, in het rekenmodel zijn rotatieveren aangebracht in de steunpunten. In de wanden op assen A en C 4Ø16 toepassen en ombuigen in de balk.

4.7

WAND AS 2, 1^E VERD. EN DAK, TUSSEN AS A-B

Wapening in de vloerrand boven de sparingen volgens Technosoft Liggers-berekening, zie Bijlage 9 – Wand as 2, 1^e verd. en dak, tussen as A-B. De belastingen zijn weergegeven in onderstaande tabel.

Wand as 2, 1e verd. en dak, tussen as A-B																
q1 :	cat.	G _k	Q _k	ψ ₀	factor lengte	breedte	lengte	aantal	G _{rep}	Q _{rep}	Q _{rep}	6.10a	6.10b	stabiliteit / opdrijven		
		kar. [kN/m ²]	kar. factor [kN/m ²]	comb.w	-	[m]	[m]	-	rep. perm.	rep. comb. (y _d)	rep. extr+comb(ψ _d)	1,35 G + 1,50 * Qcomb	1,20 G + 1,50 Qextr+comb	1,20 G + 1,50 * Qcomb	0,90 G 1,50 * QgurestG	
Verdiepingsvloer en begane grond	A	8,05	2,55	0,40	0,50	1,00	5,60	1	22,54	2,86	7,14	34,7	37,8	31,3	20,3	
						q 1	kN/m		22,5	2,9	7,1	34,7	37,8	31,3	20,3	
						lengte van de q-last: 1,000 [m]				UGT / Frequente aanw 1,33	7,1	34,7	1,45 1,45	31,3	20,3	
												totaal Qd [kN]:	35	38		



ONDERWERP: VILLA HERMAN GORTERSTRAAT, AMSTERDAM

4.8

WAND AS 2, 1^E VERD. EN DAK, TUSSEN AS B-D

Wapening volgens Technosoft Liggers-berekening, zie Bijlage 10 – Wand as 2, 1^e verd. en dak, tussen as B-D. Beide lateien functioneren als uitkragende ligger, belast door de vloer en het dak. De belastingen zijn in onderstaande tabel weergegeven.

Wand as 2, 1e verd., tussen as B-D

q1 :														
cat.	G _k	Q _k	ψ	factor	breedte	lengte	aantal	G _{rep}	Q _{rep}	Q _{rep}	6.10a	6.10b	stabiliteit / opdrijven	
	[kN/m ²]	[kN/m ²]	comb.w	lengte	[m]	[m]	-	rep. perm.	rep. comb. (y _d)	rep. extr+comb.(y _d)	1,35 G + 1,50 * Qcomb	1,20 G + 1,50 Qeet+comb	1,20 G + 1,50 * Qcomb	0,90 G 1,50 * Qgunstig
Dak	H	8,05	1,00	0,50	1,00	2,70	1	10,87			14,7	13,0	13,0	9,8
Verdiepingsvloer en begane grond	A	8,05	2,55	0,40	0,50	1,00	2,90	11,67	1,48	3,70	18,0	19,6	16,2	10,5
gevel: 100mm bakst; 250mm beton		8,25			0,50	1,00	3,05	12,58			17,0	15,1	15,1	11,3
q 1 kN/m²								35,1	1,5	3,7	49,6	47,7	44,4	31,6
lengte van de q-last: [m]								UGT / Frequente aanw totaal Qd [kN]:						

q2 :														
cat.	G _k	Q _k	ψ	factor	breedte	lengte	aantal	G _{rep}	Q _{rep}	Q _{rep}	6.10a	6.10b	stabiliteit / opdrijven	
	[kN/m ²]	[kN/m ²]	comb.w	lengte	[m]	[m]	-	rep. perm.	rep. comb. (y _d)	rep. extr+comb.(y _d)	1,35 G + 1,50 * Qcomb	1,20 G + 1,50 Qeet+comb	1,20 G + 1,50 * Qcomb	0,90 G 1,50 * Qgunstig
Dak	H	8,05	1,00	0,50	1,00	2,70	1	10,87			14,7	13,0	13,0	9,8
Verdiepingsvloer en begane grond	A	8,05	2,55	0,40	0,50	1,00	2,90	11,67	1,48	3,70	18,0	19,6	16,2	10,5
wand: 250mm beton		6,25			0,50	1,00	2,10	6,56			8,9	7,9	7,9	5,9
gevel: 100mm bakst; 250mm beton		8,25			0,50	1,00	3,05	12,58			17,0	15,1	15,1	11,3
q 2 kN/m²								41,7	1,5	3,7	58,5	55,6	52,2	37,5
lengte van de q-last: [m]								UGT / Frequente aanw totaal Qd [kN]:						

F1 :														
cat.	G _k	Q _k	ψ	factor	breedte	lengte	aantal	G _{rep}	Q _{rep}	Q _{rep}	6.10a	6.10b	stabiliteit / opdrijven	
	[kN/m ²]	[kN/m ²]	comb.w	lengte	[m]	[m]	-	rep. perm.	rep. comb. (y _d)	rep. extr+comb.(y _d)	1,35 G + 1,50 * Qcomb	1,20 G + 1,50 Qeet+comb	1,20 G + 1,50 * Qcomb	0,90 G 1,50 * Qgunstig
Dak	H	8,05	1,00	1,00	1,90	2,20	1	33,65		4,18	45,4	46,6	40,4	30,3
F 1 kN								33,6		4,2	45,4	46,6	40,4	30,3
afstand tot begin schema: [m]								UGT / Frequente aanw totaal Qd [kN]:						

Wand as 2, dak, tussen as B-D

q1 :														
cat.	G _k	Q _k	ψ	factor	breedte	lengte	aantal	G _{rep}	Q _{rep}	Q _{rep}	6.10a	6.10b	stabiliteit / opdrijven	
	[kN/m ²]	[kN/m ²]	comb.w	lengte	[m]	[m]	-	rep. perm.	rep. comb. (y _d)	rep. extr+comb.(y _d)	1,35 G + 1,50 * Qcomb	1,20 G + 1,50 Qeet+comb	1,20 G + 1,50 * Qcomb	0,90 G 1,50 * Qgunstig
Dak	H	8,05	1,00	0,50	1,00	2,90	1	11,67		1,45	15,8	16,2	14,0	10,5
gevel: 100mm bakst; 250mm beton		8,25			0,50	1,00	3,05	12,58			17,0	15,1	15,1	11,3
q 1 kN/m²								24,3		1,5	32,7	31,3	29,1	21,8
lengte van de q-last: [m]								UGT / Frequente aanw totaal Qd [kN]:						

q2 :														
cat.	G _k	Q _k	ψ	factor	breedte	lengte	aantal	G _{rep}	Q _{rep}	Q _{rep}	6.10a	6.10b	stabiliteit / opdrijven	
	[kN/m ²]	[kN/m ²]	comb.w	lengte	[m]	[m]	-	rep. perm.	rep. comb. (y _d)	rep. extr+comb.(y _d)	1,35 G + 1,50 * Qcomb	1,20 G + 1,50 Qeet+comb	1,20 G + 1,50 * Qcomb	0,90 G 1,50 * Qgunstig
Dak	H	8,05	1,00	0,50	1,00	2,90	1	11,67		1,45	15,8	16,2	14,0	10,5
wand: 250mm beton		6,25			0,50	1,00	2,10	6,56			8,9	7,9	7,9	5,9
gevel: 100mm bakst; 250mm beton		8,25			0,50	1,00	3,05	12,58			17,0	15,1	15,1	11,3
q 2 kN/m²								30,8		1,5	41,6	39,2	37,0	27,7
lengte van de q-last: [m]								UGT / Frequente aanw totaal Qd [kN]:						



4.9

KOLOM AS 4', KELDER, TUSSEN AS B-C

Wapening volgens Technosoft Kolomwapening, zie Bijlage 11 – Kolom as 4', kelder, tussen as B-C. De belasting is gebaseerd op de reactie in de funderingspaal in het Technosoft Balkroosters-model.



— 5 Bijlagen



5.1

BIJLAGE 1 – VLOERSTROOK KELDER AS C

BIJ

LA

GE



Technosoft Liggers release 6.76

12 mei 2023

Project.....: 21038 - Herman Gorterstraat

Onderdeel....: Keldervloer + kelderwand

Constructeur.: ing. 5.1, 2, e

Dimensies....: kN/m/rad

Datum.....: 10/05/2023

Bestand.....: C:\Users\5.1, 2, e\Dropbox (BREEDID)\Projecten
 2021\21038 - Herman Gorterstraat\BREED
 ID\Calculations\5_Werkfase\Keldervloer\
 20230512_Vloerstroken kelder.dlw

Herverdelen van momenten : nee Maximale deellengte : 0.500
 Ouderdom bij belasten : 28 Relatieve vochtigheid : 50%
 Doorbuigingen(beton) zijn dmv gecorrigeerde stijfheden berekend.

Fysisch lineair : Er is gerekend met de e-modulus uit de materiaaltabel.
 Fys.NLE.kort : Er is gerekend met een gecorrigeerde e-modulus (korte duur).
 Deze e-mod. is berekend mbv de krachten uit de fysisch lineair berekening.

Toegepaste normen volgens Eurocode met Nederlandse NB

Belastingen	NEN-EN 1990:2002	C2:2010,A1:2019	NB:2019(nl)
	NEN-EN 1991-1-1:2002	C1/C11:2019	NB:2019(nl)
Beton	NEN-EN 1992-1-1:2011(nl)	C2/A1:2015(nl)	NB:2016(nl)



GEOMETRIE

Ligger:1

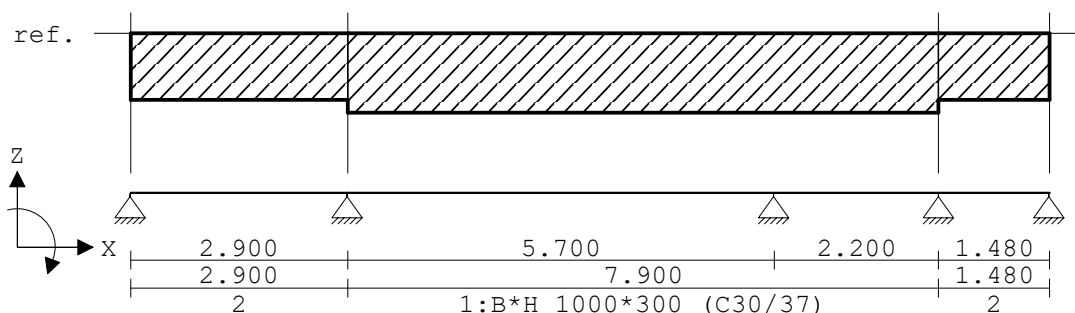

VELDBELASTINGEN

Ligger:1 B.G:1 PB (incl EG)

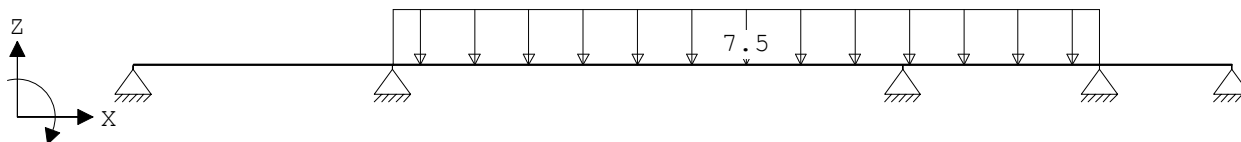

VELDBELASTINGEN

Ligger:1 B.G:2 VB

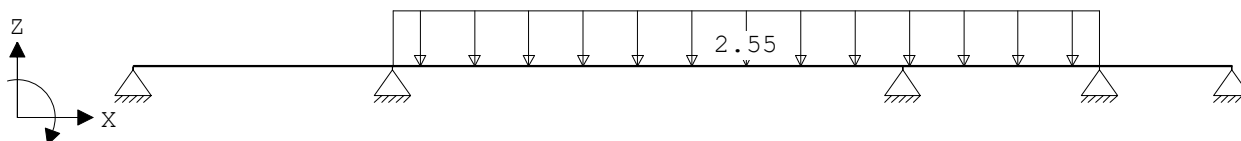

Project.....: 21038 - Herman Gorterstraat

Onderdeel....: Keldervloer + kelderwand

VELDBELASTINGEN

Ligger:1 B.G:3 Waterdruk

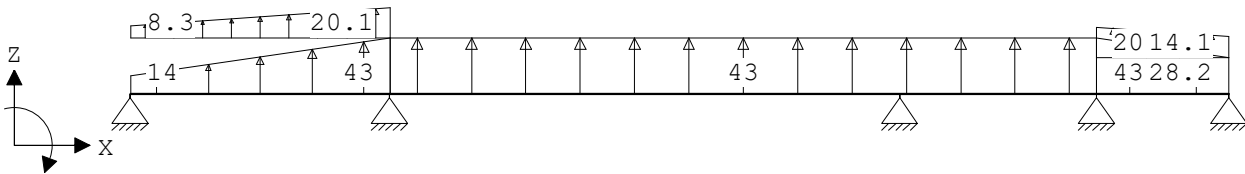

VELDBELASTINGEN

Ligger:1 B.G:4 Bovenbelasting

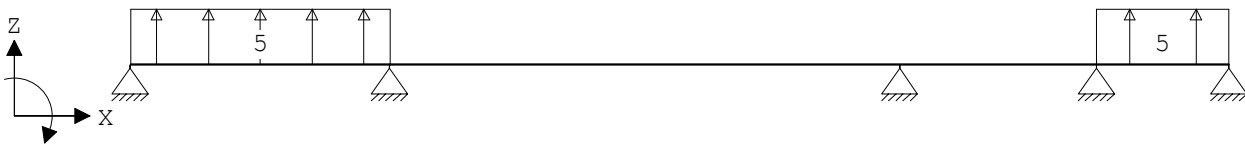

BELASTINGCOMBINATIES

BC	Type	BG	Gen.	Factor	BG	Gen.	Factor	BG	Gen.	Factor	BG	Gen.	Factor
1	Fund.	1	Perm	1.35									
2	Fund.	1	Perm	1.35	2	psi0	1.50	3	Extr	1.20	4	psi0	1.50
3	Fund.	1	Perm	1.20	2	Extr	1.50	3	Extr	1.20	4	Extr	1.50
4	Fund.	1	Perm	0.90									
5	Fund.	1	Perm	0.90	2	psi0	1.50	3	Extr	1.20	4	psi0	1.50
6	Fund.	1	Perm	0.90	2	Extr	1.50	3	Extr	1.20	4	Extr	1.50
7	Fund.	1	Perm	0.90	3	Extr	1.20	4	Extr	1.50			
8	Fund.	1	Perm	0.90	3	Extr	1.20						
9	Fund.	1	Perm	1.20	2	Extr	1.50						
10	Fund.	1	Perm	1.20	2	Extr	1.50	4	Extr	1.50			
11	Kar.	1	Perm	1.00	2	Extr	1.00	3	Extr	1.00	4	Extr	1.00
12	Kar.	1	Perm	1.00	3	Extr	1.00	4	Extr	1.00			
13	Kar.	1	Perm	1.00	2	Extr	1.00						
14	Freq.	1	Perm	1.00									
15	Freq.	1	Perm	1.00	2	psi1	1.00	3	Extr	1.00			
16	Quas.	1	Perm	1.00									
17	Quas.	1	Perm	1.00	2	psi2	1.00	3	Extr	1.00	4	psi2	1.00
18	Blij.	1	Perm	1.00									

GUNSTIGE WERKING PERMANENTE BELASTINGEN

BC Velden met gunstige werking

- 1 Geen
- 2 Geen
- 3 Geen
- 4 Alle velden de factor:0.90
- 5 Alle velden de factor:0.90, 1.20
- 6 Alle velden de factor:0.90, 1.20
- 7 Alle velden de factor:0.90, 1.20
- 8 Alle velden de factor:0.90, 1.20
- 9 Geen
- 10 Geen

Project.....: 21038 - Herman Gorterstraat

Onderdeel....: Keldervloer + kelderwand

OMHULLENDE VAN DE FUNDAMENTELE COMBINATIES

MOMENTEN Fysisch lineair

Ligger:1 Fundamentele combinatie

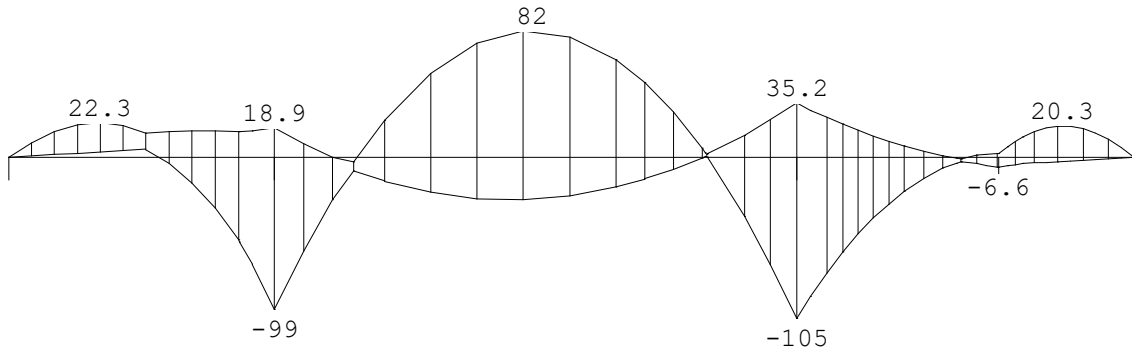

DWARSKRACHTEN Fysisch lineair

Ligger:1 Fundamentele combinatie

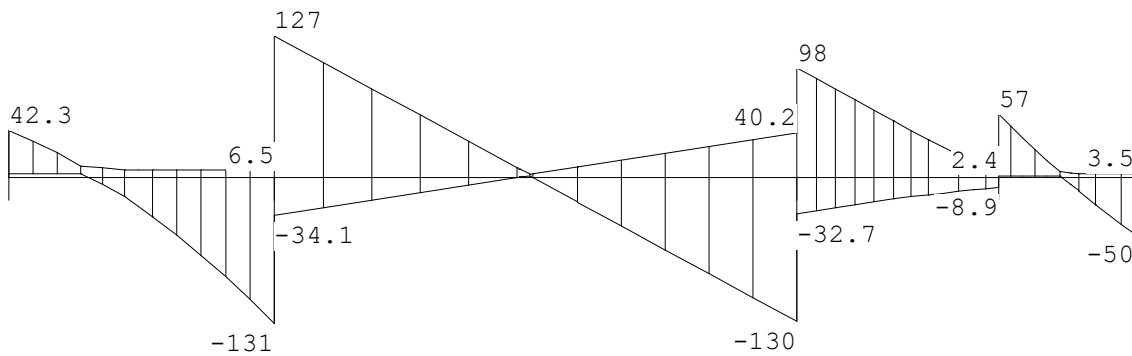

Fmin:-42.3	-258	-228	-65	-50
Fmax:-3.41	40.6	73	0.91	3.45

REACTIES Fysisch lineair

Ligger:1 Fundamentele combinatie

Stp	Fmin	Fmax	Mmin	Mmax
1	-42.28	-3.41	0.00	0.00
2	-258.45	40.62	0.00	0.00
3	-227.71	72.87	0.00	0.00
4	-64.66	0.91	0.00	0.00
5	-50.45	3.45	0.00	0.00

Hoofdwapening Fysisch lineair

Ligger:1 Fundamentele combinatie

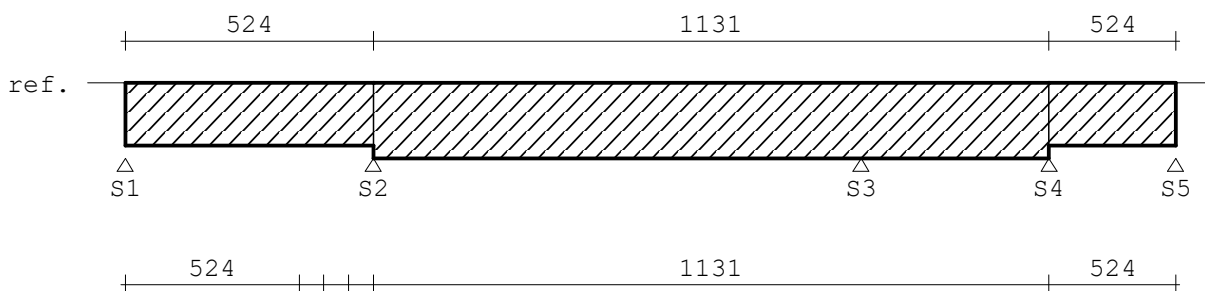

Project.....: 21038 - Herman Gorterstraat

Onderdeel....: Keldervloer + kelderwand

MEd dekkingslijn Fysisch lineair

Ligger:1 Fundamentele combinatie

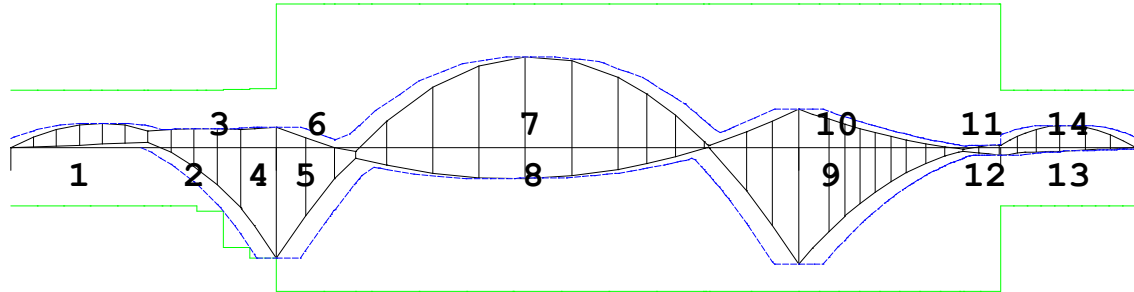

Hoofdwapening

Ligger:1

Geb.	Vanaf [mm]	Tot [mm]	M _{Ed} [kNm]	M _{Rd} [kNm]	z [mm]	B/O	A _b [mm ²]	A _a [mm ²]	Opm.
1	S1+0	S2-1405	22.34	52.19	140	Bov	290*	524	54
1	S1+0	S2-1405	22.34	52.19	140	Ond	0	524	
2	S2-1405	S2-381	17.02	52.19	140	Bov	290*	524	54
2	S2-1405	S2-381	17.02	52.19	140	Ond	0	576	
3	S2-1251	S2+0	-99.28	-99.31	190	Bov	0	524	
3	S2-1251	S2+0	-99.28	-99.31	190	Ond	1084	1084	
4	S2-381	S2+0	18.94	52.19	140	Bov	290*	524	54
4	S2-381	S2+0	18.94	52.19	140	Ond	0	1084	
5	S2+0	S2+630	18.94	129.50	240	Bov	348*	1131	54
5	S2+0	S2+630	18.94	129.50	240	Ond	0	1131	
6	S2+0	S2+862	-99.28	-129.50	240	Bov	0	1131	
6	S2+0	S2+862	-99.28	-129.50	240	Ond	848	1131	
7	S2+862	S3-1014	-27.82	-129.50	240	Bov	0	1131	
7	S2+862	S3-1014	-27.82	-129.50	240	Ond	348*	1131	54
8	S2+896	S3-982	82.17	129.50	240	Bov	688	1131	
8	S2+896	S3-982	82.17	129.50	240	Ond	0	1131	
9	S3-982	S4-523	35.24	129.50	240	Bov	348*	1131	54
9	S3-982	S4-523	35.24	129.50	240	Ond	0	1131	
10	S3-975	S4-398	-105.03	-129.50	240	Bov	0	1131	
10	S3-975	S4-398	-105.03	-129.50	240	Ond	902	1131	
11	S4-398	S4+0	-6.60	-129.50	240	Bov	0	1131	
11	S4-398	S4+0	-6.60	-129.50	240	Ond	348*	1131	54
12	S4-333	S4+0	2.31	129.50	240	Bov	348*	1131	54
12	S4-333	S4+0	2.31	129.50	240	Ond	0	1131	
13	S4+0	S5+0	20.29	52.19	140	Bov	290*	524	54
13	S4+0	S5+0	20.29	52.19	140	Ond	0	524	
14	S4+0	S5+0	-6.60	-52.19	140	Bov	0	524	
14	S4+0	S5+0	-6.60	-52.19	140	Ond	290*	524	54

Project.....: 21038 - Herman Gorterstraat

Onderdeel....: Keldervloer + kelderwand

Hoofdwapening

Ligger:1

Geb.	Pos. [mm]	M_{Ed} [kNm]	M_{Rd} [kNm]	z B/O [mm]	A_b [mm ²]	A_a [mm ²]	Basiswapening +Bijlegwapening	Opm.
------	--------------	-------------------	-------------------	---------------	-----------------------------	-----------------------------	----------------------------------	------

Opmerkingen

Alle maten zijn zonder verschuiving van de m-lijn en verankering

[54] * = Eisen met betrekking tot minimum wapening ten behoeve van gecontroleerde scheurvorming zijn toegepast volgens art. 7.3.2.

[93] De wapening bij de doorsnede overgang is niet getoetst vlg. NEN-EN 1992-1-1 art.9.9.

Scheurvorming volgens artikel 7.3.4

Ligger:1

Geb.	Pos. [mm]	Zijde	$M_{E;freq}$ [kNm]	$s_{r,max}$ [mm]	$\epsilon_{sm}-\epsilon_{cm}$ [%]	w_k [mm]	k_x	w_{max} [mm]	U.C.	Opm.
1	S1+992	Bov	13.00	260	0.365	0.095	1.20	0.360	0.26	
2	S2-769	Bov	8.07	260	0.227	0.059	1.20	0.360	0.16	
3	S2+0	Ond	-76.46	208	1.376	0.287	1.00	0.300	0.96	
4	S2+0	Bov	10.99	260	0.309	0.080	1.20	0.360	0.22	
5	S2+0	Bov	10.99	226	0.118	0.027	1.20	0.360	0.07	
6	S2+0	Ond	-76.46	226	0.914	0.207	1.20	0.360	0.57	
7	S2+2578	Ond	-15.31	226	0.165	0.037	1.20	0.360	0.10	
8	S2+2811	Bov	64.74	226	0.704	0.159	1.20	0.360	0.44	
9	S3+0	Bov	19.62	226	0.211	0.048	1.20	0.360	0.13	
10	S3+0	Ond	-82.62	226	1.024	0.232	1.20	0.360	0.64	
11	S4+0	Ond	-2.44	226	0.026	0.006	1.20	0.360	0.02	
12	S4-12	Bov	1.63	226	0.018	0.004	1.20	0.360	0.01	
13	S4+702	Bov	15.30	260	0.430	0.112	1.20	0.360	0.31	
14	S4+0	Ond	-2.44	260	0.069	0.018	1.00	0.300	0.06	

Toetsing doorbuiging

Veld	Mtg	Lengte [m]	Type	wtot [mm]	Zeeg [mm]	w [mm]	--Toel.1-- [mm]	Toel.2 *L [mm]	u.c.
1	db	2.90	Quasi-Blijvend Eind	-0.4	0	-0.4	11.6	0.004	20.0 0.04
	db		Frequent Bijk			-0.5	5.8	0.002	15.0 0.09
2	db	5.70	Quasi-Blijvend Eind	9.4	0	9.4	22.8	0.004	20.0 0.47
	db		Frequent Bijk			10.0	11.4	0.002	15.0 0.88
3	db	2.20	Quasi-Blijvend Eind	-0.6	0	-0.6	8.8	0.004	20.0 0.07
	db		Frequent Bijk			-0.6	4.4	0.002	15.0 0.15
4	db	1.48	Quasi-Blijvend Eind	0.2	0	0.2	5.9	0.004	20.0 0.04
	db		Frequent Bijk			0.3	3.0	0.002	15.0 0.09

Project.....: 21038 - Herman Gorterstraat

Onderdeel....: Keldervloer + kelderwand

DOORBUIGINGEN w1 [mm]

Ligger:1 Blijvende combinatie

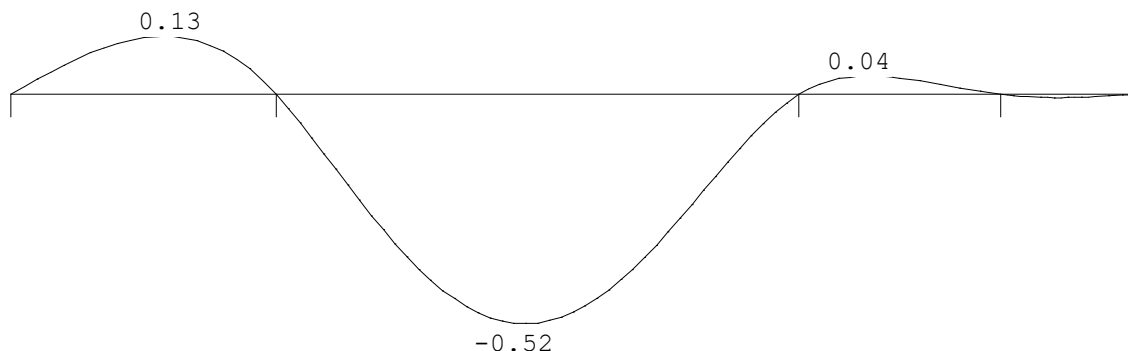

DOORBUIGINGEN w2 [mm]

Ligger:1 Quasi-blijvende combinatie

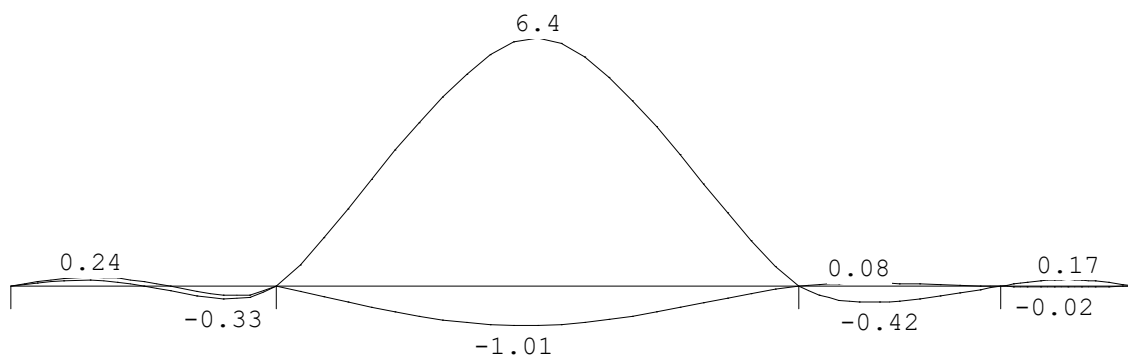

DOORBUIGINGEN w_{bij} [mm]

Ligger:1 Karakteristieke combinatie

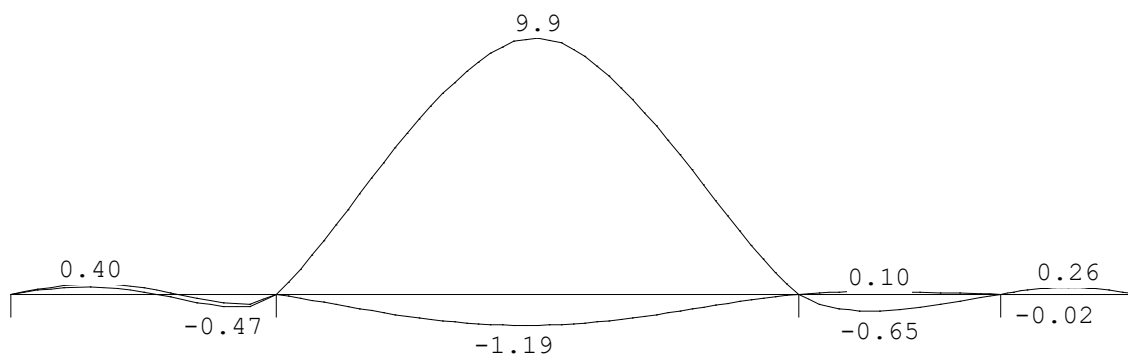

DOORBUIGINGEN w_{max} [mm]

Ligger:1 Karakteristieke combinatie

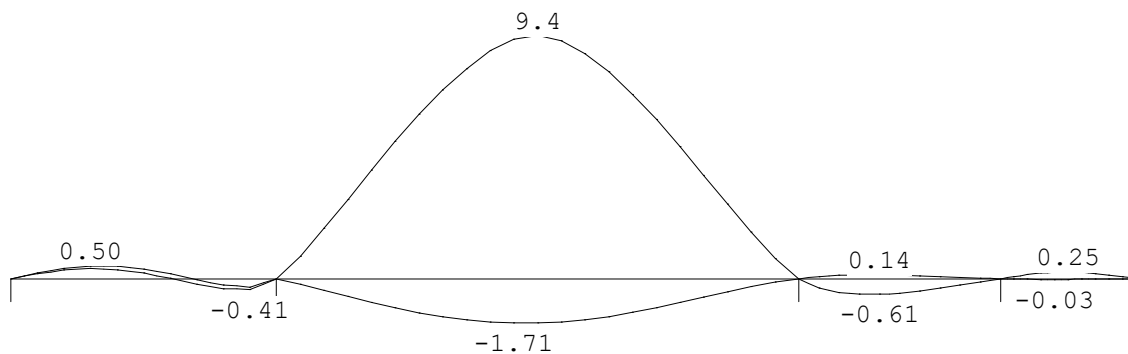

Project.....: 21038 - Herman Gorterstraat

Onderdeel....: Keldervloer + kelderwand

DOORBUIGINGEN

Karakteristieke combinatie

Veld	Zijde	positie [m]	l_{rep} [mm]	w_1 [mm]	w_2 [mm]	-- w_{bij} -- [mm] [lrep/]		w_{tot} [mm]	w_c [mm]	-- w_{max} -- [mm] [lrep/]	
1	Neg.	2.320	2900	0.1	-0.3	-0.5	6118	-0.4		-0.4	7707
1	Pos.	0.870	2900	0.1	0.2	0.4	7184	0.5		0.5	5839
2	Neg.	2.591	5700	-0.5	-1.0	-1.2	4770	-1.7		-1.7	3332
2	Pos.	2.850	5700	-0.5	6.4	9.9	577	9.4		9.4	609
3	Neg.	0.880	2200	0.0	-0.4	-0.6	3406	-0.6		-0.6	3636
4	Pos.	0.740	1480	-0.0	0.2	0.3	5687	0.3		0.3	5853

DOORBUIGINGEN w_{bij} [mm]

Ligger:1 Frequente combinatie

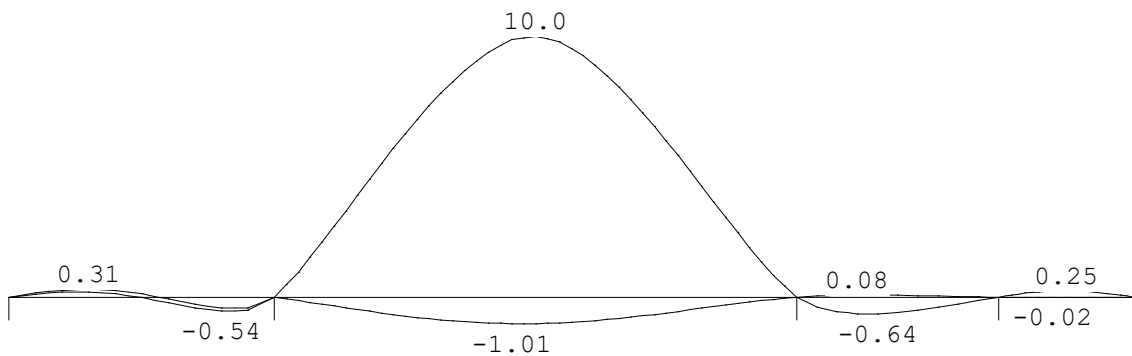

DOORBUIGINGEN w_{max} [mm]

Ligger:1 Frequente combinatie

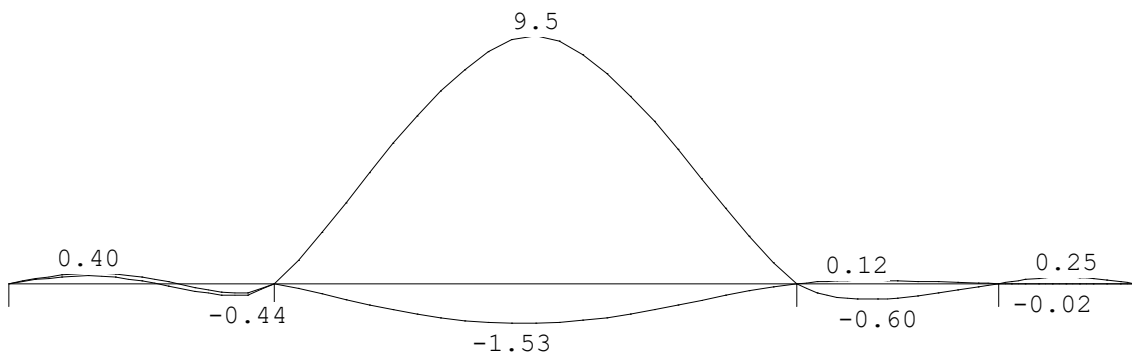

DOORBUIGINGEN

Frequente combinatie

Veld	Zijde	positie [m]	l_{rep} [mm]	w_1 [mm]	w_2 [mm]	-- w_{bij} -- [mm] [lrep/]		w_{tot} [mm]	w_c [mm]	-- w_{max} -- [mm] [lrep/]	
1	Neg.	2.320	2900	0.1	-0.3	-0.5	5374	-0.4		-0.4	6562
1	Pos.	0.870	2900	0.1	0.2	0.3	9402	0.4		0.4	7224
2	Neg.	2.591	5700	-0.5	-1.0	-1.0	5628	-1.5		-1.5	3729
2	Pos.	2.850	5700	-0.5	6.4	10.0	569	9.5		9.5	600
3	Neg.	0.880	2200	0.0	-0.4	-0.6	3427	-0.6		-0.6	3660
4	Pos.	0.740	1480	-0.0	0.2	0.3	5808	0.2		0.2	5981

Project.....: 21038 - Herman Gorterstraat

Onderdeel....: Keldervloer + kelderwand

DOORBUIGINGEN w_{bij} [mm]

Ligger:1 Quasi-blijvende combinatie

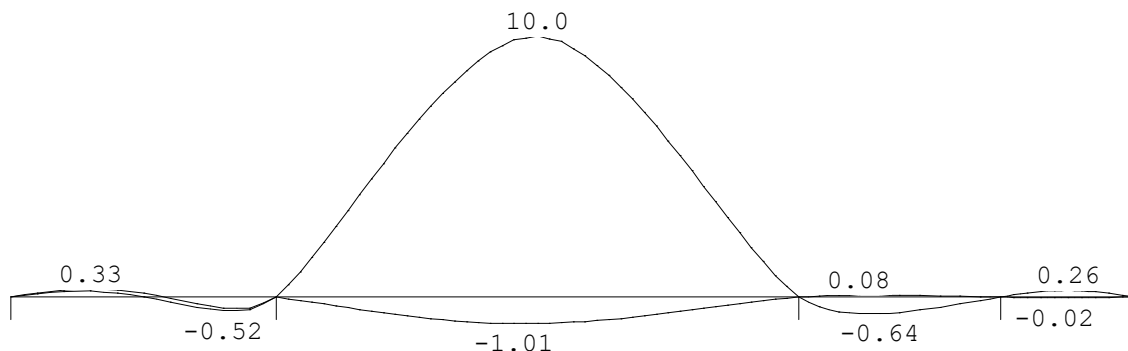

DOORBUIGINGEN w_{max} [mm]

Ligger:1 Quasi-blijvende combinatie

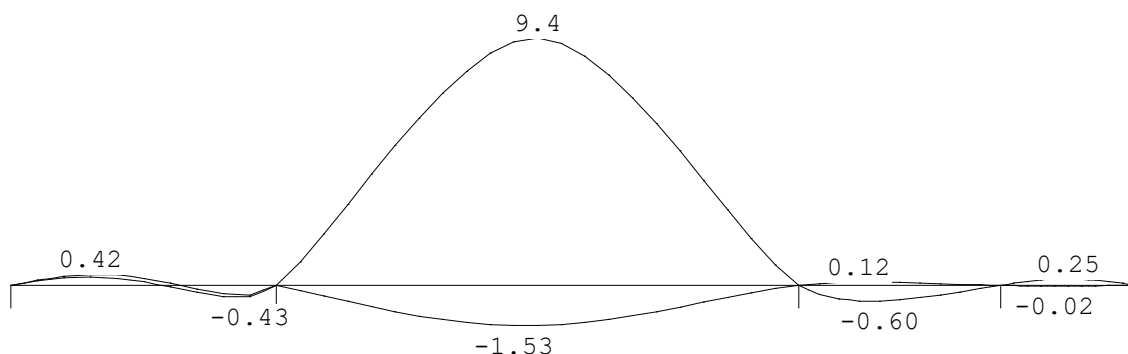

DOORBUIGINGEN

Quasi-blijvende combinatie

Veld	Zijde	positie [m]	l_{rep} [mm]	w_1 [mm]	w_2 [mm]	w_{bij} [mm]	l_{rep} [mm]	w_{tot} [mm]	w_c [mm]	w_{max} [mm]	l_{rep} [mm]
1	Neg.	2.320	2900	0.1	-0.3	-0.5	5583	-0.4	-0.4	6877	
1	Pos.	0.870	2900	0.1	0.2	0.3	8897	0.4	0.4	6923	
2	Neg.	2.591	5700	-0.5	-1.0	-1.0	5628	-1.5	-1.5	3729	
2	Pos.	2.850	5700	-0.5	6.4	10.0	572	9.4	9.4	603	
3	Neg.	0.880	2200	0.0	-0.4	-0.6	3435	-0.6	-0.6	3669	
4	Pos.	0.740	1480	-0.0	0.2	0.3	5790	0.2	0.2	5962	

5.2

BIJLAGE 2 – UITVOER TECHNOSOFT BALKROOSTERS

BIJ

LA

GE



Technosoft Balkroosters release 6.77

29 jun 2023

Project.....: 21038 - Herman Gorterstraat

Constructeur.: 5.1, 2, e

Dimensies....: kN/m/rad

Datum.....: 19/09/2022

Bestand.....: C:\Users\5.1, 2, e\Dropbox (BREEDID)\Projecten
2021\21038 - Herman Gorterstraat\BREED
ID\Calculations\5_Werkfase\Bestaande
palen\20230626_21038_balkroosters model_bestaande
palen_v3.grw

Torsiefac.....: 0 %

Betrouwbaarheidsklasse : 2 Referentieperiode : 50
Ouderdom bij belasten : 28 Relatieve vochtigheid : 50%
Doorbuigingen(beton) zijn dmv gecorrigeerde stijfheden berekend.

Fysisch lineair : Er is gerekend met de e-modulus uit de materiaaltabel.
Fys.NLE.kort : Er is gerekend met een gecorrigeerde e-modulus (korte duur).
Deze e-mod. is berekend mbv de krachten uit de fysisch lineair berekening.

Toegepaste normen volgens Eurocode met Nederlandse NB

Belastingen	NEN-EN 1990:2002	C2:2010,A1:2019	NB:2019(nl)
	NEN-EN 1991-1-1:2002	C1/C11:2019	NB:2019(nl)
Beton	NEN-EN 1992-1-1:2011(nl)	C2/A1:2015(nl)	NB:2016(nl)

Project.....: 21038 - Herman Gorterstraat

GEOMETRIE

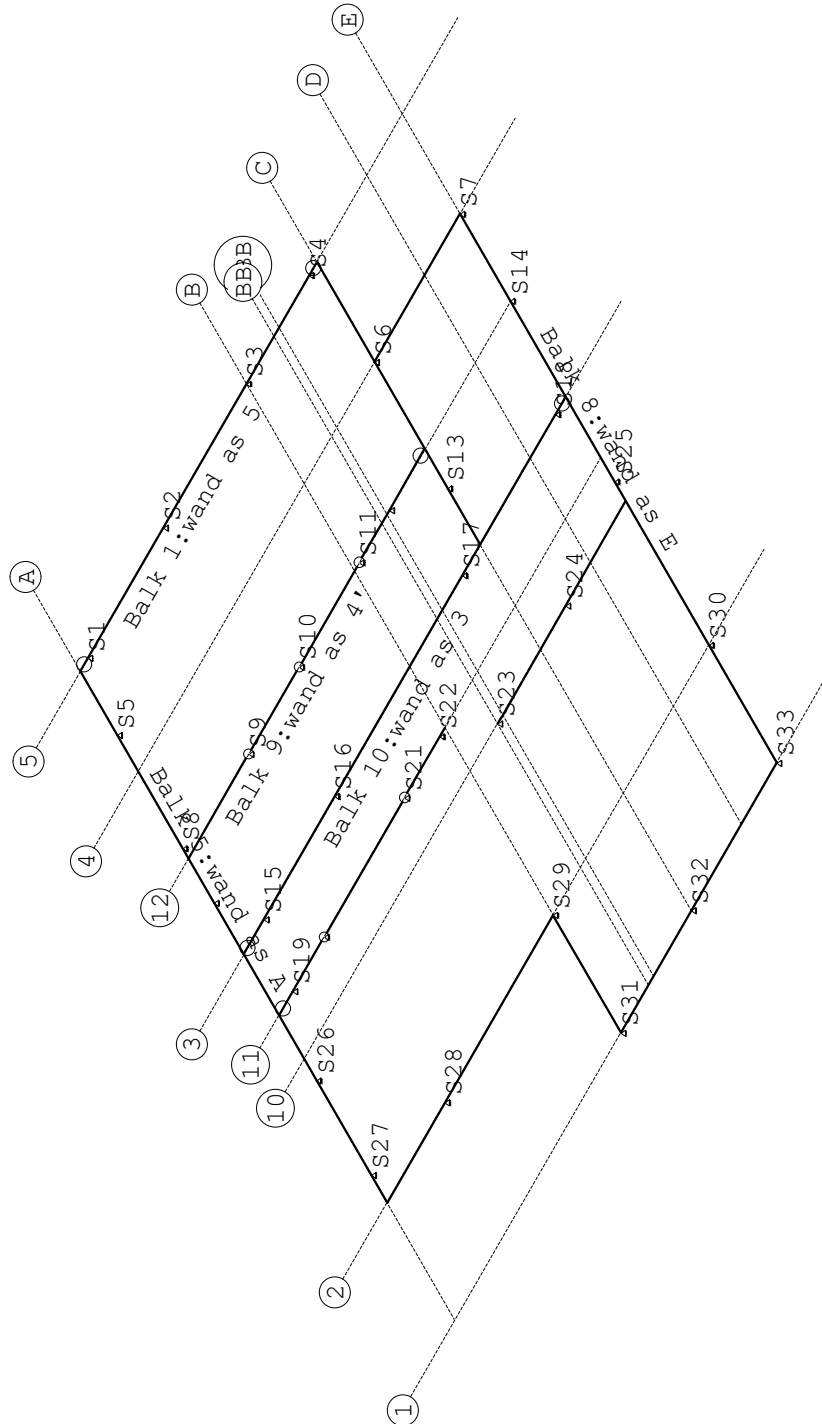

MATERIALEN

Mt	Kwaliteit	E-modulus [N/mm ²]	S.G.	Pois.	Uitz. coëff
1	C30/37	9465	25.0	0.20	1.0000e-05

Project.....: 21038 - Herman Gorterstraat

MATERIALEN vervolg

Mt	Kwaliteit	Cement	Kruipfac.
1	C30/37		2.47





PROFIELEN [mm]

Prof.	Omschrijving	Materiaal	Oppervlak	Torsietr.	Traagheid	Vormf.
1	B*H 250*2960	1:C30/37	7.400e+05	1.460e+10	5.403e+11	0.00
2	B*H 250*300	1:C30/37	7.500e+04	7.897e+08	5.625e+08	0.00
3	B*H 250*1200	1:C30/37	3.000e+05	5.433e+09	3.600e+10	0.00
4	B*H 250*1850	1:C30/37	4.625e+05	8.816e+09	1.319e+11	0.00
5	B*H 600*600	1:C30/37	3.600e+05	1.825e+10	1.080e+10	0.00

PROFIELEN vervolg [mm]

Prof.	Staaftype	Breedte	Hoogte	Zs	Rek.As	Type	b1	h1	b2	h2
1	0:Normaal	250	2960	1480	0.00	0:RH				
2	0:Normaal	250	300	150	0.00	0:RH				
3	0:Normaal	250	1200	600	0.00	0:RH				
4	0:Normaal	250	1850	925	0.00	0:RH				
5	0:Normaal	600	600	300	0.00	0:RH				

PROFIELVORMEN [mm]

1 B*H 250*2960	
2 B*H 250*300	
3 B*H 250*1200	
4 B*H 250*1850	
5 B*H 600*600	

RASTERS

nr	aktief	X-begin	Y-begin	Hoek	X-stap	Y-stap	X-lengte	Y-lengte
1	NEE	0.000	0.000	0.0	0.100	0.100	15.000	15.000

STRAMIENLIJNEN

Nr.	Naam	X-begin	Y-begin	X-eind	Y-Eind
1	A	0.000	16.000	0.000	0.000
2	B	6.600	16.000	6.600	0.000
3	C	9.400	16.000	9.400	0.000
4	D	11.400	16.000	11.400	0.000
5	E	12.800	16.000	12.800	0.000
6	1	-1.000	0.000	15.000	0.000

Project.....: 21038 - Herman Gorterstraat

STRAMIENLIJNEN

Nr.	Naam	X-begin	Y-begin	X-eind	Y-Eind
7	2	-1.000	2.700	15.000	2.700
8	3	-1.000	8.400	15.000	8.400
9	4	-1.000	12.600	15.000	12.600
10	5	-1.000	14.900	15.000	14.900
11	10	0.000	6.000	12.800	6.000
12	11	0.000	7.000	12.800	7.000
13	12	0.000	10.600	12.800	10.600
14	BBB	7.900	15.000	7.900	0.000
15	BB	7.700	15.000	7.700	0.000

BALKEN

Nr.	Naam	Begin	Eind	Profiel
1	wand as 5	A;5	C;5	3:B*H 250*1200
2	wand as 4	C;4	E;4	1:B*H 250*2960
3	wand as 2	A;2	B;2	1:B*H 250*2960
4	wand as 1	B;1	E;1	1:B*H 250*2960
5	wand as A	A;2	A;5	1:B*H 250*2960
6	wand as B	B;1	B;2	1:B*H 250*2960
7	wand as C	C;3	C;5	1:B*H 250*2960
8	wand as E	E;1	E;4	1:B*H 250*2960
9	wand as 4'	A;12	C;12	Zie Doorsnedesectoren
10	wand as 3	A;3	E;3	Zie Doorsnedesectoren
11	wand as 3'	A;11	B;11	Zie Doorsnedesectoren
12	wand as 3''	10;BB	E;10	Zie Doorsnedesectoren

BALKEN vervolg

Nr.	Naam	Aansl.begin	Aansl.eind	Excentr.	Pasm.begin	Pasm.eind	Opm.
1	wand as 5	WD-	WD-	0.000	0.000	0.000	
2	wand as 4	WDM	WDM	0.000	0.000	0.000	
3	wand as 2	WDM	WDM	0.000	0.000	0.000	
4	wand as 1	WDM	WDM	0.000	0.000	0.000	
5	wand as A	WDM	WDM	0.000	0.000	0.000	
6	wand as B	WDM	WDM	0.000	0.000	0.000	
7	wand as C	WDM	WDM	0.000	0.000	0.000	
8	wand as E	WDM	WDM	0.000	0.000	0.000	
9	wand as 4'	WDM	WD-	0.000	0.000	0.000	
10	wand as 3	WD-	WD-	0.000	0.000	0.000	
11	wand as 3'	WD-	WDM	0.000	0.000	0.000	
12	wand as 3''	WDM	WDM	0.000	0.000	0.000	

Opmerkingen:

De torsie traagheid van alle balken is tot 0% gereduceerd

Project.....: 21038 - Herman Gorterstraat

DOORSNEDESECTOREN

Balk	Vanaf	Tot	Lengte	Profiel	Eindcode
Balk 9:wand ..	0.000	2.400	2.400	1:B*H 250*2960	0:Scharnier
Balk 9:wand ..	2.400	4.400	2.000	2:B*H 250*300	0:Scharnier
Balk 9:wand ..	4.400	6.800	2.400	1:B*H 250*2960	0:Scharnier
Balk 9:wand ..	6.800	8.000	1.200	2:B*H 250*300	1:Vast
Balk 9:wand ..	8.000	9.400	1.400	2:B*H 250*300	1:Vast
Balk 10:wand..	0.000	11.100	11.100	1:B*H 250*2960	1:Vast
Balk 10:wand..	11.100	12.800	1.700	4:B*H 250*1850	1:Vast
Balk 11:wand..	0.000	0.400	0.400	1:B*H 250*2960	1:Vast
Balk 11:wand..	0.400	1.800	1.400	1:B*H 250*2960	0:Scharnier
Balk 11:wand..	1.800	5.000	3.200	2:B*H 250*300	0:Scharnier
Balk 11:wand..	5.000	6.600	1.600	1:B*H 250*2960	1:Vast
Balk 12:wand..	0.000	0.200	0.200	5:B*H 600*600	1:Vast
Balk 12:wand..	0.200	5.100	4.900	1:B*H 250*2960	1:Vast

STEUNPUNTTYPEN

Nr. : 1  Assenstelsel: Globaal
 Afmeting : standaard (0) Rotatie X:Vrij
 Inheinv.: 0.7 m +NAP Verplaatsing Z:Veerwaarde: 75000
 Lengte : 17.700 Rotatie Y:Vrij
 Min.afst.: 0.500

STEUNPUNTEN

Nr.	Naam	Steunpunttype	Balk	Positie	Excentr.	Hoek	Opm:
1		1:standaard	Balk 1:wand as 5	0.3	0.000	0.000	
2		1:standaard	Balk 1:wand as 5	3.3	0.000	0.000	
3		1:standaard	Balk 1:wand as 5	6.600	0.000	0.000	
4		1:standaard	Balk 1:wand as 5	9.1	0.000	0.000	
5		1:standaard	Balk 5:wand as A	10.7300	0.000	0.000	
6		1:standaard	Balk 2:wand as 4	0.000	0.000	0.000	
7		1:standaard	Balk 2:wand as 4	3.400	0.000	0.000	
8		1:standaard	Balk 5:wand as A	8.130	0.000	0.000	
9		1:standaard	Balk 9:wand as 4'	2.400	0.000	0.000	
10		1:standaard	Balk 9:wand as 4'	4.400	0.000	0.000	
11		1:standaard	Balk 9:wand as 4'	6.800	0.000	0.000	
12		1:standaard	Balk 9:wand as 4'	8	0.000	0.000	
13		1:standaard	Balk 7:wand as C	1.3	0.000	0.000	
14		1:standaard	Balk 8:wand as E	10.6	0.000	0.000	
15		1:standaard	Balk 10:wand as 3	0.8	0.000	0.000	
16		1:standaard	Balk 10:wand as 3	3.62	0.000	0.000	
17		1:standaard	Balk 10:wand as 3	8.7	0.000	0.000	
18		1:standaard	Balk 10:wand as 3	12.40	0.000	0.000	
19		1:standaard	Balk 11:wand as..	.55	0.000	0.000	
20		1:standaard	Balk 11:wand as..	1.800	0.000	0.000	
21		1:standaard	Balk 11:wand as..	5.000	0.000	0.000	
22		1:standaard	Balk 11:wand as..	6.400	0.000	0.000	
23		1:standaard	Balk 12:wand as..	0.000	0.000	0.000	
24		1:standaard	Balk 12:wand as..	2.700	0.000	0.000	

Project.....: 21038 - Herman Gorterstraat

STEUNPUNTEN

Nr.	Naam	Steunpunttype	Balk	Positie	Excentr.	Hoek	Opm:
25		1:standaard	Balk 8:wand as E	6.4500	0.000	0.000	
26		1:standaard	Balk 5:wand as A	2.8	0.000	0.000	
27		1:standaard	Balk 5:wand as A	.62	0.000	0.000	
28		1:standaard	Balk 3:wand as 2	2.3	0.000	0.000	
29		1:standaard	Balk 3:wand as 2	6.600	0.000	0.000	
30		1:standaard	Balk 8:wand as E	2.700	0.000	0.000	
31		1:standaard	Balk 4:wand as 1	0.000	0.000	0.000	
32		1:standaard	Balk 4:wand as 1	2.800	0.000	0.000	
33		1:standaard	Balk 4:wand as 1	6.200	0.000	0.000	
34		1:standaard	Balk 5:wand as A	6.8800	0.000	0.000	

BELASTINGGEVALLEN

B.G.	Omschrijving	Belast/onbelast	Ψ_0	Ψ_1	Ψ_2	e.g.
1	Permanent	2:Permanent EN1991				-1.00
2	Veranderlijk	0:Alles tegelijk	0.50	0.50	0.30	0.00

BELASTINGGEVALLEN

B.G.	Omschrijving	Type
1	Permanent	1 Permanente belasting
2	Veranderlijk	2 Ver. bel. pers. ed. (q_k)

Project.....: 21038 - Herman Gorterstraat

VELDBELASTINGEN

B.G:1 Permanent

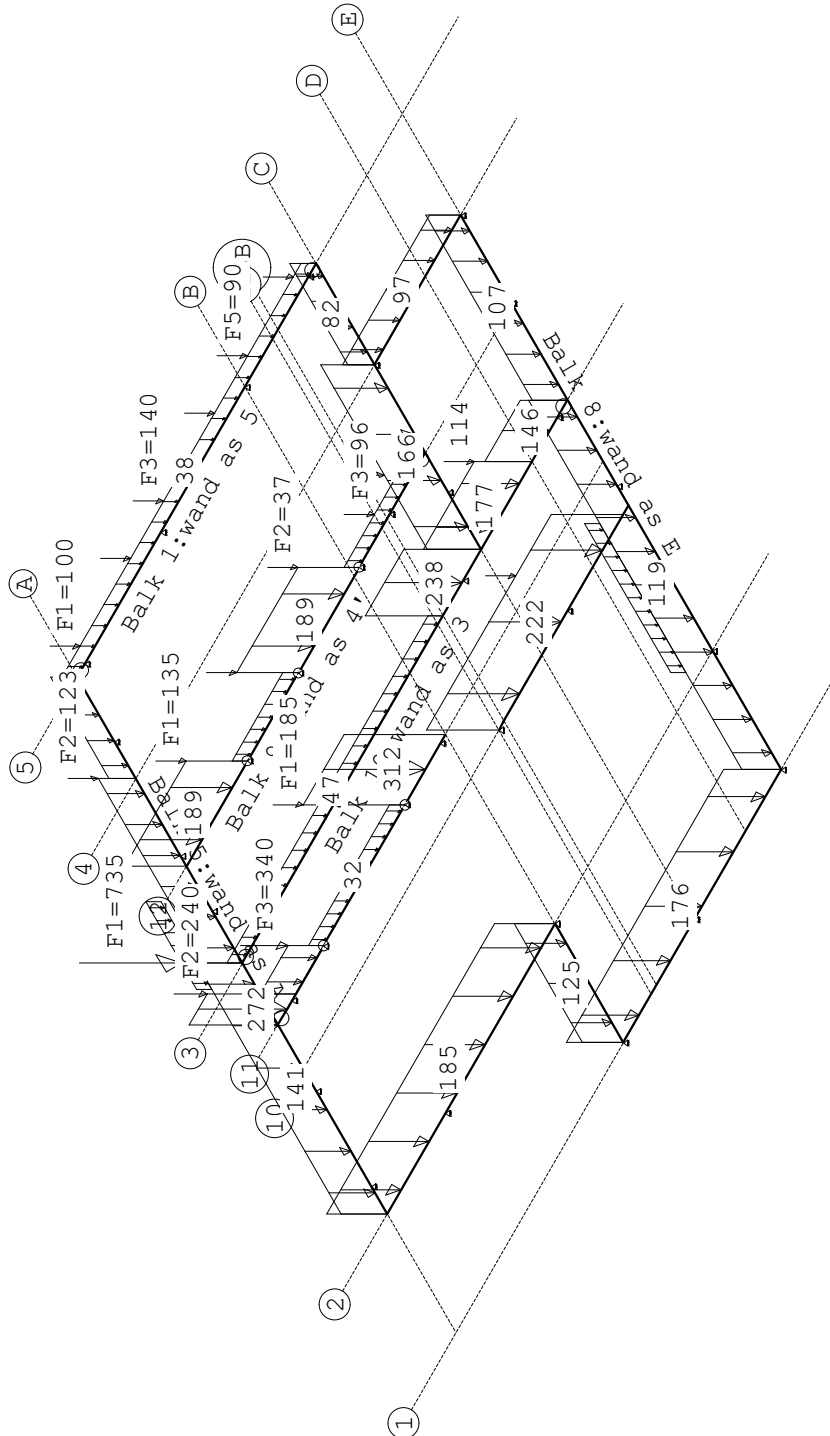

VELDBELASTINGEN

B.G:1 Permanent

Balk	Last Type	q1/p/m	q2	Afstand	Lengte	Exc.
Balk 1:wand as 5	1 1:q-last	-38.000	-38.000	0.000	9.400	0.000
Balk 1:wand as 5	2 8:Puntlast	-100.000		0.700		0.000
Balk 1:wand as 5	3 8:Puntlast	-95.000		2.700		0.000
Balk 1:wand as 5	4 8:Puntlast	-140.000		4.000		0.000
Balk 1:wand as 5	5 8:Puntlast	-95.000		6.000		0.000

Project.....: 21038 - Herman Gorterstraat

VELDBELASTINGEN

B.G:1 Permanent

Balk	Last	Type	q1/p/m	q2	Afstand	Lengte	Exc.
Balk 1:wand as 5	6	8:Puntlast	-90.000		7.300		0.000
Balk 1:wand as 5	7	8:Puntlast	-85.000		9.100		0.000
Balk 2:wand as 4	1	1:q-last	-97.000	-97.000	0.000	3.400	0.000
Balk 3:wand as 2	1	1:q-last	-185.000	-185.000	0.000	6.600	0.000
Balk 4:wand as 1	1	1:q-last	-176.000	-176.000	0.000	6.200	0.000
Balk 5:wand as A	1	1:q-last	-141.000	-141.000	0.000	5.700	0.000
Balk 5:wand as A	2	1:q-last	-114.000	-114.000	5.700	4.200	0.000
Balk 5:wand as A	3	8:Puntlast	-735.000		5.700		0.000
Balk 5:wand as A	4	8:Puntlast	-123.000		9.900		0.000
Balk 5:wand as A	5	1:q-last	-81.000	-81.000	9.900	2.300	0.000
Balk 5:wand as A	6	1:q-last	-10.000	-10.000	5.100	2.000	0.000
Balk 6:wand as B	1	1:q-last	-125.000	-125.000	0.000	2.700	0.000
Balk 7:wand as C	1	1:q-last	-166.000	-166.000	0.000	4.200	0.000
Balk 7:wand as C	2	1:q-last	-82.000	-82.000	4.200	2.300	0.000
Balk 7:wand as C	3	8:Puntlast	-35.000		1.700		0.000
Balk 8:wand as E	1	1:q-last	-119.000	-119.000	0.000	8.400	0.000
Balk 8:wand as E	2	1:q-last	-107.000	-107.000	8.400	4.200	0.000
Balk 8:wand as E	3	1:q-last	-10.000	-10.000	2.200	3.400	0.000
Balk 9:wand as 4'	1	1:q-last	-189.000	-189.000	0.000	2.400	0.000
Balk 9:wand as 4'	2	1:q-last	-38.000	-38.000	2.400	2.000	0.000
Balk 9:wand as 4'	3	1:q-last	-189.000	-189.000	4.400	2.400	0.000
Balk 9:wand as 4'	4	1:q-last	-38.000	-38.000	6.800	2.600	0.000
Balk 9:wand as 4'	5	8:Puntlast	-135.000		2.400		0.000
Balk 9:wand as 4'	6	8:Puntlast	-135.000		4.400		0.000
Balk 9:wand as 4'	7	8:Puntlast	-37.000		6.800		0.000
Balk 9:wand as 4'	8	8:Puntlast	-96.000		8.000		0.000
Balk 10:wand as 3	1	1:q-last	-238.000	-238.000	7.900	1.500	0.000
Balk 10:wand as 3	2	8:Puntlast	-114.000		11.400		0.000
Balk 10:wand as 3	3	1:q-last	-47.000	-47.000	0.000	7.900	0.000
Balk 10:wand as 3	4	1:q-last	-177.000	-177.000	9.400	2.000	0.000
Balk 10:wand as 3	5	1:q-last	-146.000	-146.000	11.400	1.400	0.000
Balk 11:wand as 3'	1	1:q-last	-272.000	-272.000	0.000	0.700	0.000
Balk 11:wand as 3'	2	1:q-last	-110.000	-110.000	0.700	1.100	0.000
Balk 11:wand as 3'	3	1:q-last	-32.000	-32.000	1.800	3.200	0.000
Balk 11:wand as 3'	4	1:q-last	-312.000	-312.000	5.000	1.600	0.000
Balk 11:wand as 3'	5	8:Puntlast	-240.000		0.700		0.000
Balk 11:wand as 3'	6	8:Puntlast	-340.000		1.800		0.000
Balk 11:wand as 3'	7	8:Puntlast	-185.000		5.000		0.000
Balk 12:wand as ..	1	1:q-last	-222.000	-222.000	0.000	4.900	0.000
Balk 12:wand as ..	2	8:Puntlast	-106.000		3.500		0.000

Project.....: 21038 - Herman Gorterstraat

VELDBELASTINGEN

B.G:2 Veranderlijk

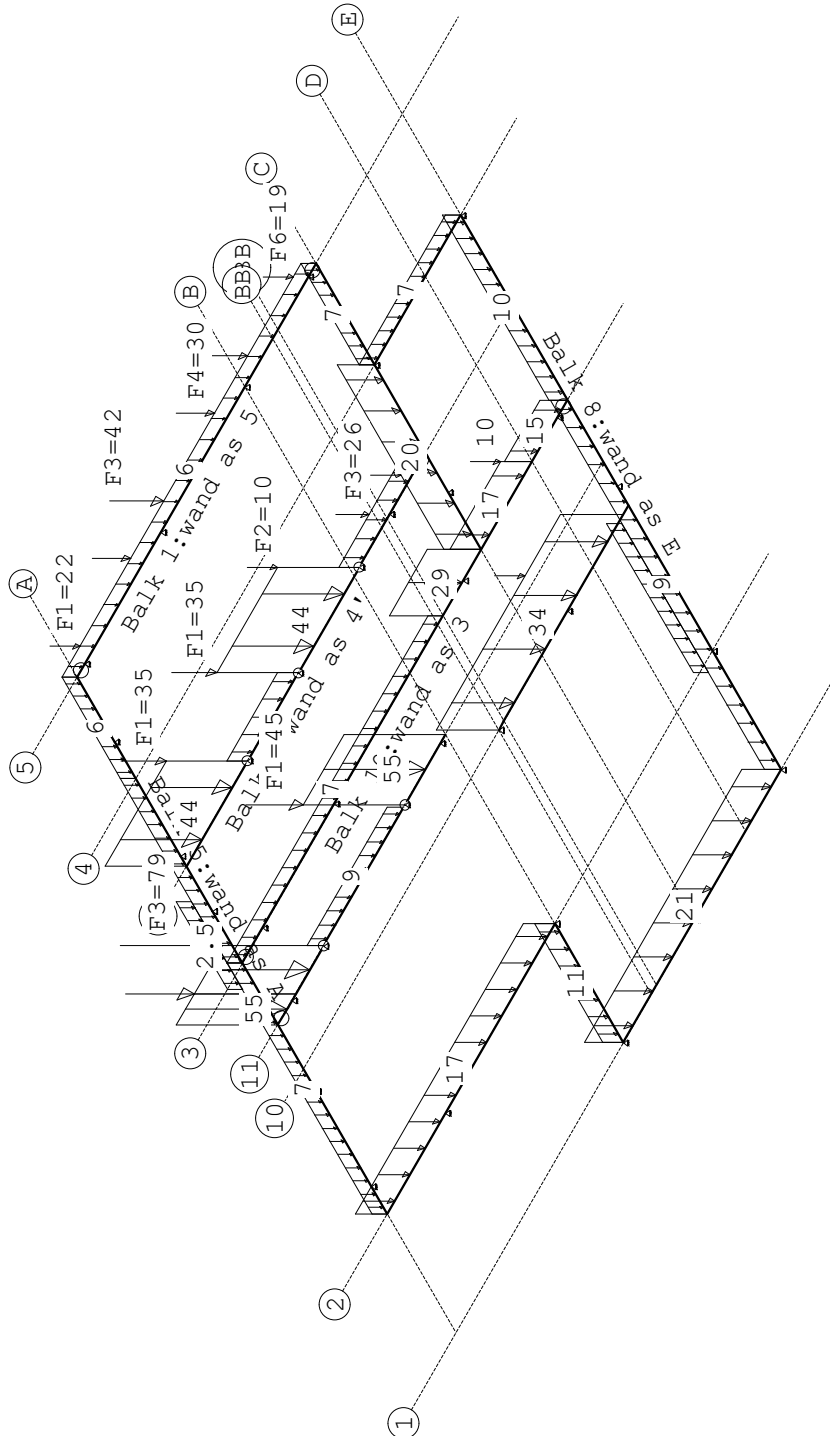

VELDBELASTINGEN

B.G:2 Veranderlijk

Balk	Last Type	q1/p/m	q2	Afstand	Lengte	Exc.
Balk 1:wand as 5	1 1:q-last	-6.000	-6.000	0.000	9.400	0.000
Balk 1:wand as 5	2 8:Puntlast	-22.000		0.700		0.000
Balk 1:wand as 5	3 8:Puntlast	-30.000		2.700		0.000
Balk 1:wand as 5	4 8:Puntlast	-42.000		4.000		0.000
Balk 1:wand as 5	5 8:Puntlast	-30.000		6.000		0.000

Project.....: 21038 - Herman Gorterstraat

VELDBELASTINGEN

B.G:2 Veranderlijk

Balk	Last	Type	q1/p/m	q2	Afstand	Lengte	Exc.
Balk 1:wand as 5	6	8:Puntlast	-28.000		7.300		0.000
Balk 1:wand as 5	7	8:Puntlast	-19.000		9.100		0.000
Balk 2:wand as 4	1	1:q-last	-7.000	-7.000	0.000	3.400	0.000
Balk 3:wand as 2	1	1:q-last	-17.000	-17.000	0.000	6.600	0.000
Balk 4:wand as 1	1	1:q-last	-21.000	-21.000	0.000	6.200	0.000
Balk 5:wand as A	1	1:q-last	-7.000	-7.000	0.000	5.700	0.000
Balk 5:wand as A	2	1:q-last	-6.000	-6.000	5.700	4.200	0.000
Balk 5:wand as A	3	1:q-last	-6.000	-6.000	9.900	2.300	0.000
Balk 5:wand as A	4	1:q-last	-2.500	-2.500	5.100	2.000	0.000
Balk 6:wand as B	1	1:q-last	-11.000	-11.000	0.000	2.700	0.000
Balk 7:wand as C	1	1:q-last	-20.000	-20.000	0.000	4.200	0.000
Balk 7:wand as C	2	1:q-last	-7.000	-7.000	4.200	2.300	0.000
Balk 7:wand as C	3	8:Puntlast	-1.000		1.700		0.000
Balk 8:wand as E	1	1:q-last	-9.000	-9.000	0.000	8.400	0.000
Balk 8:wand as E	2	1:q-last	-10.000	-10.000	8.400	4.200	0.000
Balk 8:wand as E	3	1:q-last	-2.500	-2.500	2.200	3.400	0.000
Balk 9:wand as 4'	1	1:q-last	-44.000	-44.000	0.000	2.400	0.000
Balk 9:wand as 4'	2	1:q-last	-11.000	-11.000	2.400	2.000	0.000
Balk 9:wand as 4'	3	1:q-last	-44.000	-44.000	4.400	2.400	0.000
Balk 9:wand as 4'	4	1:q-last	-11.000	-11.000	6.800	2.600	0.000
Balk 9:wand as 4'	5	8:Puntlast	-35.000		2.400		0.000
Balk 9:wand as 4'	6	8:Puntlast	-35.000		4.400		0.000
Balk 9:wand as 4'	7	8:Puntlast	-10.000		6.800		0.000
Balk 9:wand as 4'	8	8:Puntlast	-26.000		8.000		0.000
Balk 10:wand as 3	1	1:q-last	-29.000	-29.000	7.900	1.500	0.000
Balk 10:wand as 3	2	8:Puntlast	-10.000		11.400		0.000
Balk 10:wand as 3	3	1:q-last	-7.000	-7.000	0.000	7.900	0.000
Balk 10:wand as 3	4	1:q-last	-17.000	-17.000	9.400	2.000	0.000
Balk 10:wand as 3	5	1:q-last	-15.000	-15.000	11.400	1.400	0.000
Balk 11:wand as 3'	1	1:q-last	-55.000	-55.000	0.000	0.700	0.000
Balk 11:wand as 3'	2	1:q-last	-55.000	-55.000	0.700	1.100	0.000
Balk 11:wand as 3'	3	1:q-last	-9.000	-9.000	1.800	3.150	0.000
Balk 11:wand as 3'	4	1:q-last	-55.000	-55.000	5.000	1.600	0.000
Balk 11:wand as 3'	5	8:Puntlast	-53.000		0.700		0.000
Balk 11:wand as 3'	6	8:Puntlast	-79.000		1.800		0.000
Balk 11:wand as 3'	7	8:Puntlast	-45.000		5.000		0.000
Balk 12:wand as ..	1	1:q-last	-34.000	-34.000	0.000	4.900	0.000
Balk 12:wand as ..	2	8:Puntlast	-11.000		3.500		0.000

BELASTINGCOMBINATIES

BC Type	BG Gen.	Factor	BG Gen.	Factor	BG Gen.	Factor	BG Gen.	Factor
1 Fund.	1 Perm	1.35						
2 Fund.	1 Perm	1.35	2 psi0	1.50				
3 Fund.	1 Perm	1.20	2 Extr	1.50				
4 Fund.	1 Perm	0.90						
5 Fund.	1 Perm	0.90	2 psi0	1.50				
6 Fund.	1 Perm	0.90	2 Extr	1.50				
7 Kar.	1 Perm	1.00	2 Extr	1.00				
8 Freq.	1 Perm	1.00						

Project.....: 21038 - Herman Gorterstraat

BELASTINGCOMBINATIES

BC Type	BG Gen. Factor	BG Gen. Factor	BG Gen. Factor	BG Gen. Factor
9 Freq.	1 Perm 1.00	2 psi1 1.00		
10 Quas.	1 Perm 1.00			
11 Quas.	1 Perm 1.00	2 psi2 1.00		
12 Blij.	1 Perm 1.00			

Project.....: 21038 - Herman Gorterstraat

DWARSKRACHTEN Fysisch lineair

Fundamentele combinatie

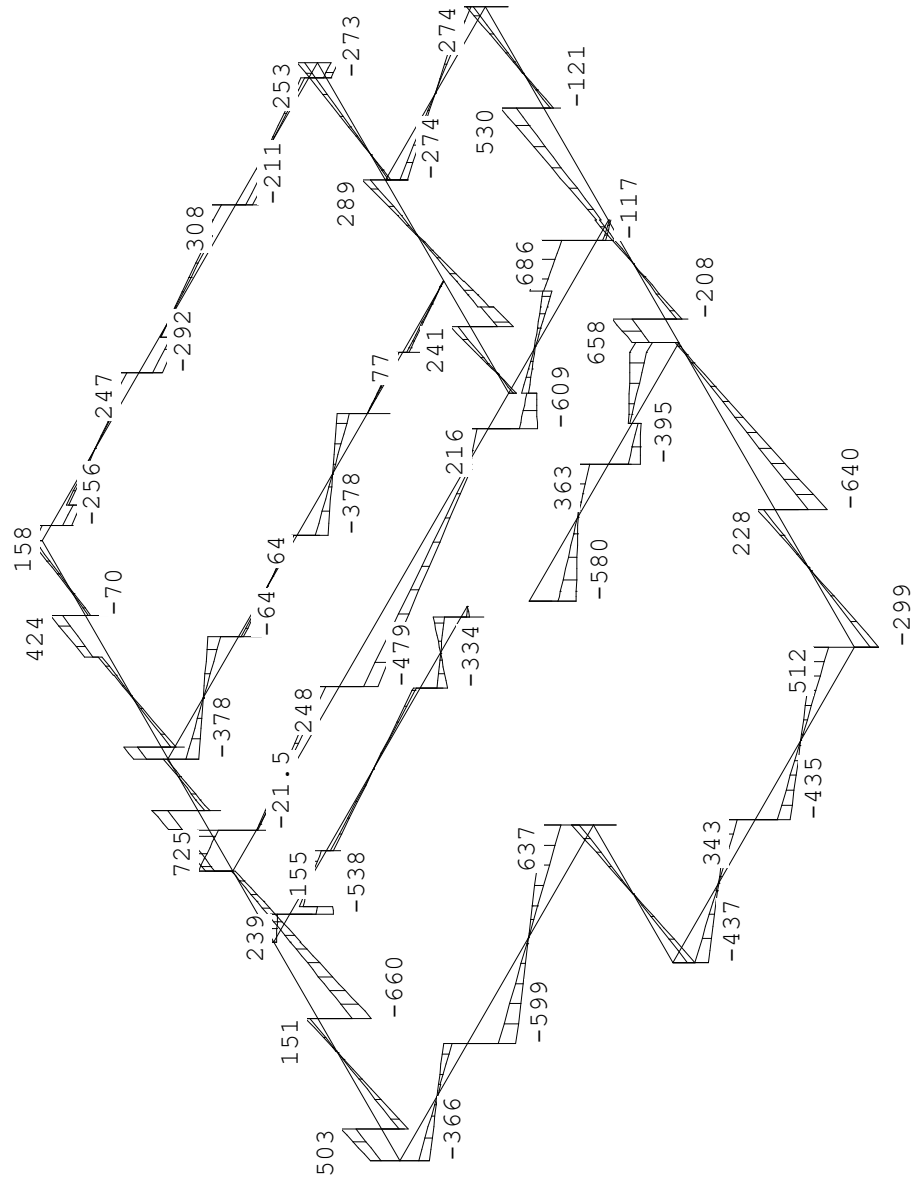

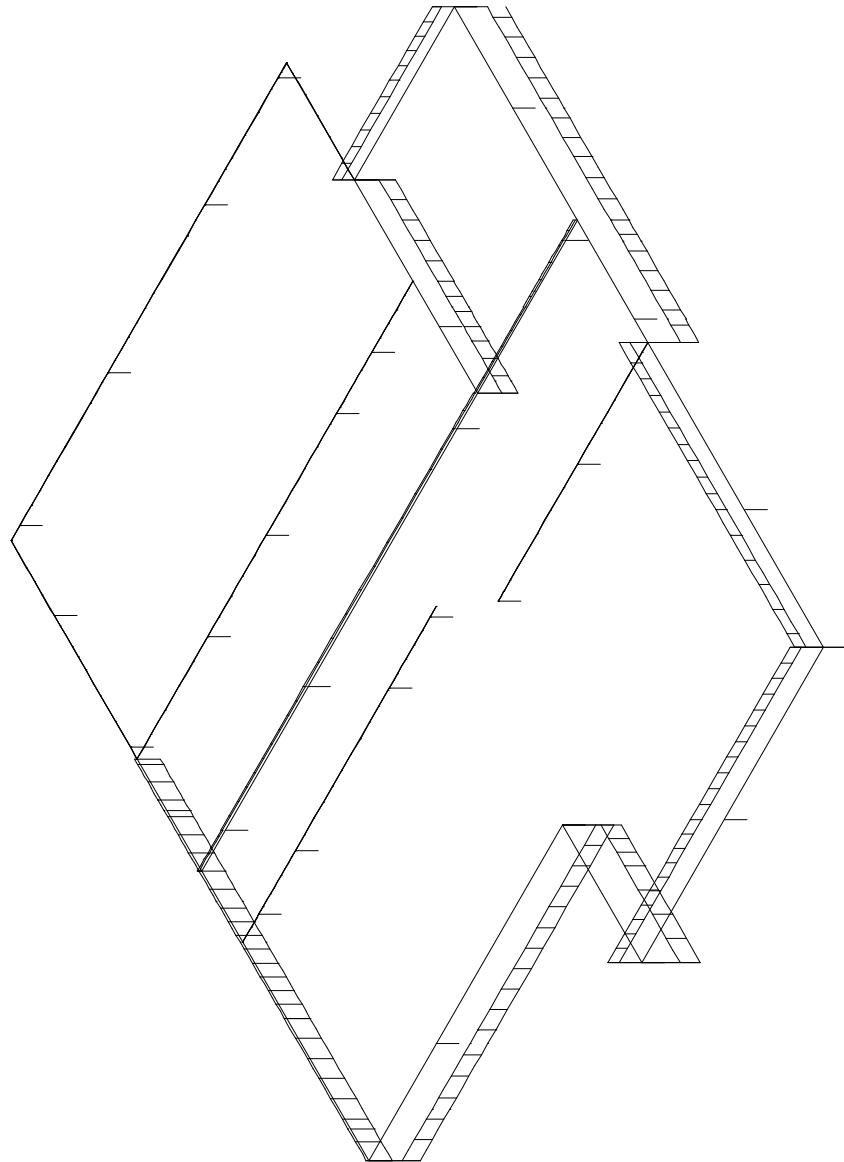

Project.....: 21038 - Herman Gorterstraat

REACTIES Fysisch lineair

Fundamentele combinatie

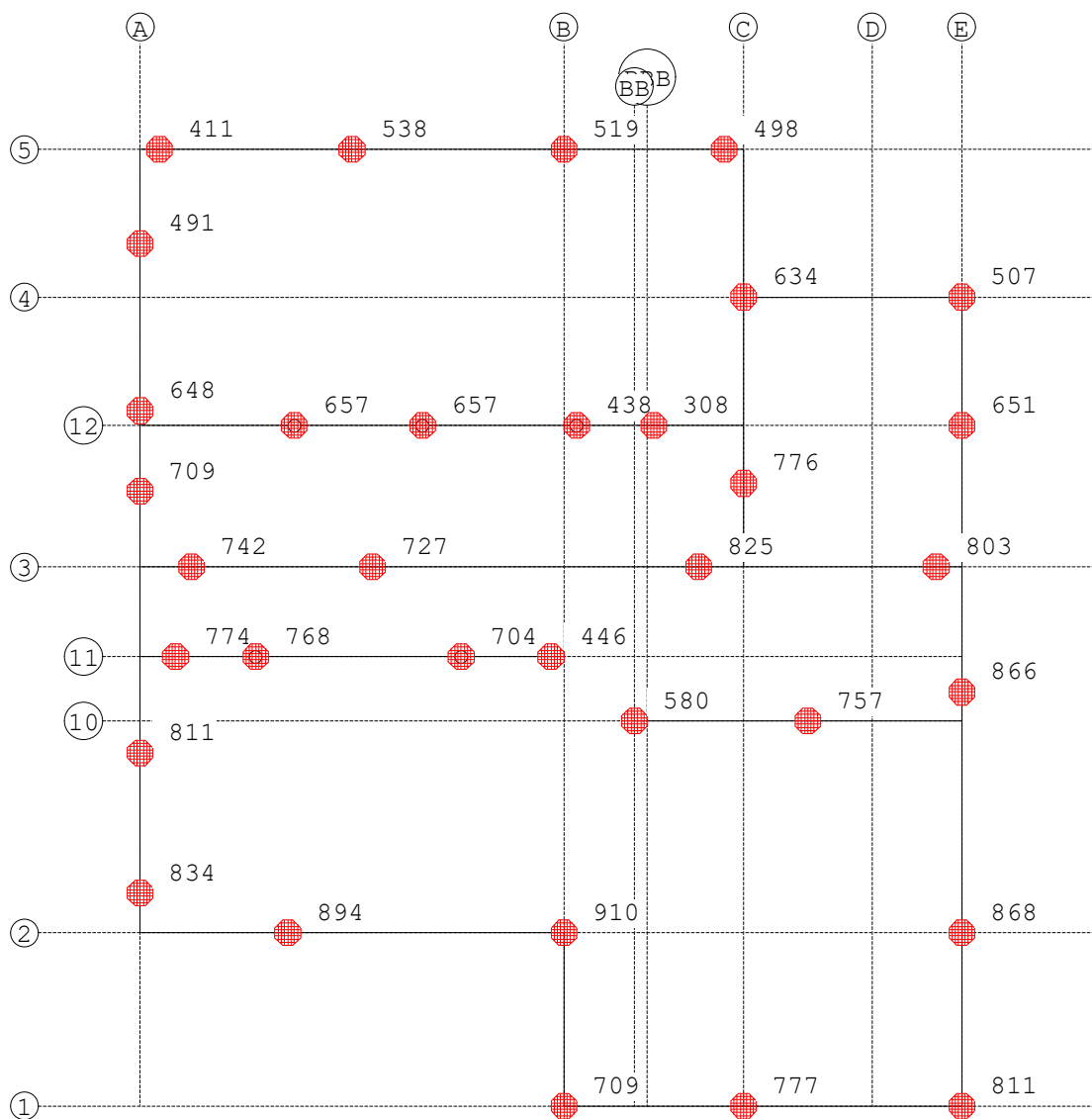

REACTIES Fysisch lineair

Fundamentele combinatie

Balk	Stp	MX		Z		MY	
		min.	max.	min.	max.	min.	max.
1	1	0.00	0.00	257.18	411.33	0.00	0.00
1	2	0.00	0.00	314.21	538.39	0.00	0.00
1	3	0.00	0.00	305.43	518.98	0.00	0.00
1	4	0.00	0.00	309.95	498.32	0.00	0.00
2	6	0.00	0.00	399.51	634.48	0.00	0.00
2	7	0.00	0.00	323.78	506.88	0.00	0.00
3	28	0.00	0.00	572.19	893.61	0.00	0.00
3	29	0.00	0.00	579.33	909.91	0.00	0.00

Project.....: 21038 - Herman Gorterstraat

REACTIES Fysisch lineair Fundamentele combinatie

Balk	Stp	MX		Z		MY	
		min.	max.	min.	max.	min.	max.
4	31	0.00	0.00	447.70	709.28	0.00	0.00
4	32	0.00	0.00	491.12	777.23	0.00	0.00
4	33	0.00	0.00	513.41	810.79	0.00	0.00
5	27	-0.00	0.00	536.03	833.57	0.00	0.00
5	26	0.00	0.00	521.46	810.67	0.00	0.00
5	34	-0.00	0.00	455.50	709.39	0.00	0.00
5	8	-0.00	0.00	415.05	647.66	0.00	0.00
5	5	0.00	0.00	312.57	491.17	0.00	0.00
6	31	0.00	0.00	447.70	709.28	0.00	0.00
6	29	0.00	0.00	579.33	909.91	0.00	0.00
7	13	0.00	0.00	490.10	775.69	0.00	0.00
7	6	0.00	0.00	399.51	634.48	0.00	0.00
8	33	0.00	0.00	513.41	810.79	0.00	0.00
8	30	0.00	0.00	549.81	868.13	0.00	0.00
8	25	0.00	0.00	548.47	865.84	0.00	0.00
8	14	0.00	0.00	413.76	650.63	0.00	0.00
8	7	0.00	0.00	323.78	506.88	0.00	0.00
9	9	0.00	0.00	381.49	656.85	0.00	0.00
9	10	0.00	0.00	381.49	656.85	0.00	0.00
9	11	0.00	0.00	254.29	438.13	0.00	0.00
9	12	0.00	0.00	178.82	308.21	0.00	0.00
10	15	0.00	0.00	475.57	741.60	0.00	0.00
10	16	0.00	0.00	462.35	726.97	0.00	0.00
10	17	0.00	0.00	521.73	824.95	0.00	0.00
10	18	0.00	0.00	508.96	802.92	0.00	0.00
11	19	0.00	0.00	481.00	773.57	-0.00	-0.00
11	20	0.00	0.00	415.74	767.76	0.00	0.00
11	21	0.00	0.00	419.25	704.00	0.00	0.00
11	22	0.00	0.00	271.95	445.65	-0.00	0.00
12	23	0.00	0.00	356.45	580.36	0.00	0.00
12	24	0.00	0.00	473.82	757.12	0.00	0.00

PROFIELGEGEVENS Balk **[N] [mm]** t.b.v. profiel:1 B*H 250*2960

Algemeen

Materiaal : C30/37

Project.....: 21038 - Herman Gorterstraat

Doorsnede

breedte : 250 hoogte : 2960 zwaartepunt tov onderkant : 1480
 Fictieve dikte : 230.5

Betonkwaliteit element : C30/37 Kruipcoëf. : 2.470
 Staalkwaliteit hoofwapening : 500 ϵ_{uk} : 2.50
 Staalkwaliteit beugels : 500

Betondekking

	Boven	Onder
Milieu	XC1	XC1
Hoofdwapening	2de laag	2de laag
Nominale dekking	17	17
Toegepaste dekking	45	45
Beugel / Verdeelwapening	1ste laag	1ste laag
Nominale dekking	15	15
Toegepaste dekking	35	35

Wapening

	Boven	Onder
Diameter nuttige hoogte	12.0	12.0

Beugels

Beugeldiameter : 10
 Min. hoek betondrukdiagonaal θ : 21.8 z berekenen via: MRd

PROFIELGEGEVENS Balk**[N] [mm]**

t.b.v. profiel:2 B*H 250*300

Algemeen

Materiaal : C30/37

Doorsnede

breedte : 250 hoogte : 300 zwaartepunt tov onderkant : 150
 Fictieve dikte : 136.4

Betonkwaliteit element : C30/37 Kruipcoëf. : 2.470
 Staalkwaliteit hoofwapening : 500 ϵ_{uk} : 2.50
 Staalkwaliteit beugels : 500

Betondekking

	Boven	Onder
Milieu	XC1	XC1
Hoofdwapening	2de laag	2de laag
Nominale dekking	17	17
Toegepaste dekking	43	43
Beugel / Verdeelwapening	1ste laag	1ste laag
Nominale dekking	15	15
Toegepaste dekking	35	35

Wapening

	Boven	Onder
Diameter nuttige hoogte	12.0	12.0

Beugels

Beugeldiameter : 8
 Min. hoek betondrukdiagonaal θ : 21.8 z berekenen via: MRd

PROFIELGEGEVENS Balk**[N] [mm]**

t.b.v. profiel:3 B*H 250*1200

Algemeen

Materiaal : C30/37

Project.....: 21038 - Herman Gorterstraat

Doorsnede

breedte : 250 hoogte : 1200 zwaartepunt tov onderkant : 600
 Fictieve dikte : 206.9

Betonkwaliteit element : C30/37 Kruipcoëf. : 2.470
 Staalkwaliteit hoofwapening : 500 ϵ_{uk} : 2.50
 Staalkwaliteit beugels : 500

Betondekking

	Boven	Onder
Milieu	XC1	XC1
Hoofdwapening	2de laag	2de laag
Nominale dekking	17	17
Toegepaste dekking	45	45
Beugel / Verdeelwapening	1ste laag	1ste laag
Nominale dekking	15	15
Toegepaste dekking	35	35

Wapening

	Boven	Onder
Diameter nuttige hoogte	12.0	12.0

Beugels

Beugeldiameter : 10
 Min. hoek betondrukdiagonaal θ : 21.8 z berekenen via: MRd

PROFIELGEGEVENS Balk**[N] [mm]**

t.b.v. profiel:4 B*H 250*1850

Algemeen

Materiaal : C30/37

Doorsnede

breedte : 250 hoogte : 1850 zwaartepunt tov onderkant : 925
 Fictieve dikte : 220.2

Betonkwaliteit element : C30/37 Kruipcoëf. : 2.470
 Staalkwaliteit hoofwapening : 500 ϵ_{uk} : 2.50
 Staalkwaliteit beugels : 500

Betondekking

	Boven	Onder
Milieu	XC1	XC1
Hoofdwapening	2de laag	2de laag
Nominale dekking	17	17
Toegepaste dekking	45	45
Beugel / Verdeelwapening	1ste laag	1ste laag
Nominale dekking	15	15
Toegepaste dekking	35	35

Wapening

	Boven	Onder
Diameter nuttige hoogte	12.0	12.0

Beugels

Beugeldiameter : 10
 Min. hoek betondrukdiagonaal θ : 21.8 z berekenen via: MRd

PROFIELGEGEVENS Balk**[N] [mm]**

t.b.v. profiel:5 B*H 600*600

Algemeen

Materiaal : C30/37

Project.....: 21038 - Herman Gorterstraat

Doorsnede

breedte : 600 hoogte : 600 zwaartepunt tov onderkant : 300
 Fictieve dikte : 300.0

Betonkwaliteit element : C30/37 Kruipcoëf. : 2.470
 Staalkwaliteit hoofwapening : 500 ϵ_{uk} : 2.50
 Staalkwaliteit beugels : 500

Betondekking

		Boven	Onder
Milieu	:	XC3	XC3
Hoofdwapening	:	2de laag	2de laag
Nominale dekking	:	30	30
Toegepaste dekking	:	43	43
Beugel / Verdeelwapening	:	1ste laag	1ste laag
Nominale dekking	:	30	30
Toegepaste dekking	:	35	35

Wapening

		Boven	Onder
Diameter nuttige hoogte	:	12.0	20.0

Beugels

Beugeldiameter : 8
 Min. hoek betondrukdiagonaal θ : 21.8 z berekenen via: MRd

Hoofdwapening Fysisch lineair

Balk 1:wand as 5

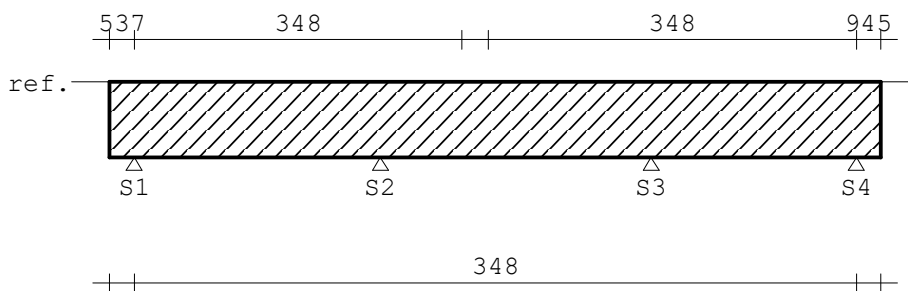

MEd dekkingslijn Fysisch lineair

Balk 1:wand as 5

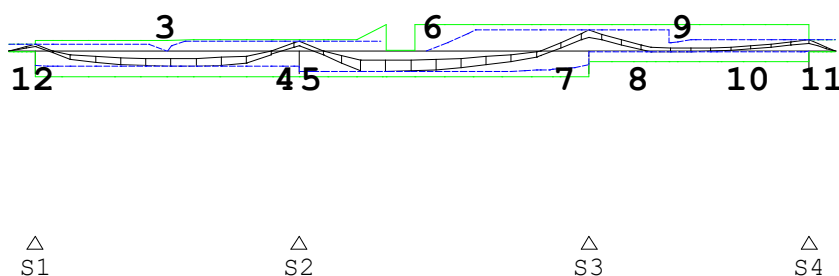

Hoofdwapening

Balk 1:wand as 5

Geb.	Vanaf [mm]	Tot [mm]	M_{Ed} [kNm]	M_{Rd} [kNm]	z [mm]	B/O	A_b [mm ²]	A_a [mm ²]	Opm.
1	S1-300	S1+0	44.71	44.75	240	Bov	537*	537	1,2
2	S1+0	S1+202	44.71	70.83	585	Bov	348*	348	2,54
3	S1+142	S2-183	-105.96	-175.69	1162	Ond	348*	348	2,54
4	S2-316	S2+0	66.43	75.58	625	Bov	348*	348	2,54

Project.....: 21038 - Herman Gorterstraat

Hoofdwapening

Balk 1:wand as 5

Geb.	Vanaf [mm]	Tot [mm]	M _{Ed} [kNm]	M _{Rd} [kNm]	z [mm]	B/O	A _b [mm ²]	A _a [mm ²]	Opm.
5	S2+0	S2+273	66.43	75.58	625	Bov	348*	348	2,54
6	S2+152	S3-417	-140.40	-177.86	1126	Ond	348*	348	2,54,68
7	S3-556	S3+0	142.84	177.86	1126	Bov	348*	348	2,54,68
8	S3+0	S3+1108	142.84	177.86	1126	Bov	348*	348	2,54,68
9	S3+652	S4-1038	-7.57	-72.89	602	Ond	348*	348	2,54
10	S3+1108	S4+0	78.82	177.86	1126	Bov	348*	348	2,54,68
11	S4+0	S4+300	78.82	78.86	240	Bov	945*	945	1,2

Opmerkingen

[1] * = Eisen met betrekking tot minimum wapening zijn toegepast, zie nationale bijlage art. 9.2.1.1(1).

[2] Benodigde wapening en inwendige hefboomsarm zijn bepaald volgens gedrongen ligger detaillering, zie nationale bijlage art. 6.1(10).

Alle maten zijn zonder verschuiving van de m-lijn en verankering

[54] * = Eisen met betrekking tot minimum wapening ten behoeve van gecontroleerde scheurvorming zijn toegepast volgens art. 7.3.2.

[68] MRd als gevolg van de gedrongen ligger berekening (NB. 6.1(10)) is groter dan MRd volgens 6.1(P). De momentweerstand en inwendige hefboomsarm volgens 6.1(P) zijn maatgevend en daarom alsnog toegepast.

Scheurvorming volgens artikel 7.3.4

Balk 1:wand as 5

Geb.	Pos. [mm]	Zijde	M _{E,freq} [kNm]	s _{r,max} [mm]	ε _{sm} -ε _{cm} [%]	w _k [mm]	k _x	w _{max} [mm]	U.C.	Opm.
1	S1+0	Bov	33.11	274	0.169	0.046	2.00	0.800	0.06	
2	S1+0	Bov	33.11	312	0.259	0.081	2.00	0.800	0.10	
3	S2-1381	Ond	-70.36	312	0.549	0.171	2.00	0.800	0.21	
4	S2+0	Bov	49.21	312	0.384	0.120	2.00	0.800	0.15	
6	S2+952	Ond	-90.11	312	0.704	0.220	2.00	0.800	0.27	
7	S3+0	Bov	105.59	312	0.825	0.257	2.00	0.800	0.32	
10	S4+0	Bov	58.22	312	0.455	0.142	2.00	0.800	0.18	
11	S4+0	Bov	58.22	221	0.171	0.038	2.00	0.800	0.05	

DWARSKRACHTEN

Fysisch lineair

Balk 1:wand as 5 Fundamentele combinatie

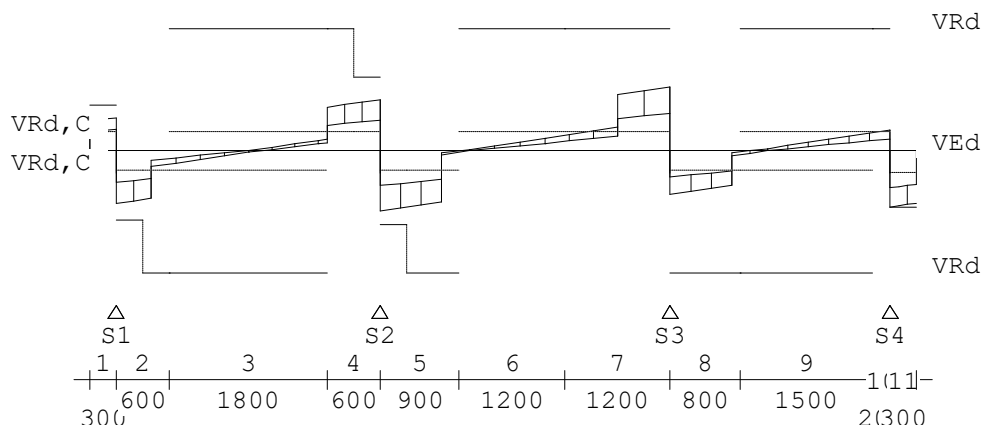

Project.....: 21038 - Herman Gorterstraat

Wring- en dwarskrachtwapening

Balk 1:wand as 5

Geb.	Vanaf [mm]	Tot [mm]	Beugels	Lengte [mm]	<Wringing >		<Dwarskr.>		V _{Ed} [kN]	T _{Ed} [kNm]	Opm.
					A _{langs} [mm ²]	A _{bg1} [mm ² /m]	A _{bg1} [mm ²]	A _{opg} [mm ²]			
1	S1-300	S1+0	Ø10-150	300	0	0	606	0	158.0	0	6,59
2	S1+0	S1+600	Ø10-300	600	0	0	402	0	255.8	0	6,59
3	S1+600	S2-600	Ø10-300	1800	0	0	219	0	64.6	0	58
4	S2-600	S2+0	Ø10-300	600	0	0	363	0	246.7	0	6,58
5	S2+0	S2+900	Ø10-300	900	0	0	429	0	291.3	0	6,59
6	S2+900	S3-1200	Ø10-300	1200	0	0	219	0	73.3	0	58
7	S3-1200	S3+0	Ø10-300	1200	0	0	274	0	308.2	0	6,58
8	S3+0	S3+800	Ø10-300	800	0	0	219	0	210.4	0	6,58
9	S3+800	S4-200	Ø10-300	1500	0	0	219	0	85.4	0	58
10	S4-200	S4+0	Ø10-300	200	0	0	219	0	98.2	0	6,58
11	S4+0	S4+300	Ø10-100	300	0	0	1507	0	272.4	0	6,59

Opmerkingen

[6] 9.2.2 (4) 50% van de dwarskrachtwapening moet uit beugels bestaan.

[58] 6.2.3: Z is berekend m.b.v. 0.9d

[59] 6.2.3: Z is berekend m.b.v. de gedrongen ligger berekening art 6.1 (10)

Wring- en dwarskrachten

Balk 1:wand as 5

Geb.	Vanaf [mm]	Tot [mm]	θ [°]	V _{Rd} [kN]	V _{Ed} V _{Rd,C} V _{Rd,Max}			T _{Ed} T _{Rd,C} T _{Rd,Max}			V _{opg}	Opm.
					-----kN-----	-----kN-----	-----kN-----	-----kNm-----	-----kNm-----	-----kNm-----		
1	S1-300	S1+0	21.8	218	158	93	218	0	45	121	0	6,59
2	S1+0	S1+600	21.8	333	256	93	533	0	45	121	0	6,59
3	S1+600	S2-600	21.8	589	65	93	941	0	45	121	0	58
4	S2-600	S2+0	21.8	356	247	93	569	0	45	121	0	6,58
5	S2+0	S2+900	21.8	356	291	93	569	0	45	121	0	6,59
6	S2+900	S3-1200	21.8	589	73	93	941	0	45	121	0	58
7	S3-1200	S3+0	21.8	589	308	93	941	0	45	121	0	6,58
8	S3+0	S3+800	21.8	589	210	93	941	0	45	121	0	6,58
9	S3+800	S4-200	21.8	589	85	93	941	0	45	121	0	58
10	S4-200	S4+0	21.8	589	98	93	941	0	45	121	0	6,58
11	S4+0	S4+300	30.0	274	272	105	274	0	45	152	0	6,59

Project.....: 21038 - Herman Gorterstraat

Schuifspanningen

Balk 1:wand as 5

Geb.	Vanaf [mm]	Tot [mm]	θ [°]	V_{Ed} [kN]	$v_{Rd,C}$	$v_{Rd,S}$	$v_{Ed} < v_{Rd} < v_{Rd,Max}$ [N/mm ²]	Opm.
------	---------------	-------------	-----------------	------------------	------------	------------	--	------

Opmerkingen

[6] 9.2.2 (4) 50% van de dwarskrachtwapening moet uit beugels bestaan.

[58] 6.2.3: Z is berekend m.b.v. 0.9d

[59] 6.2.3: Z is berekend m.b.v. de gedrongen ligger berekening art 6.1 (10)

Hoofdwapening Fysisch lineair

Balk 2:wand as 4

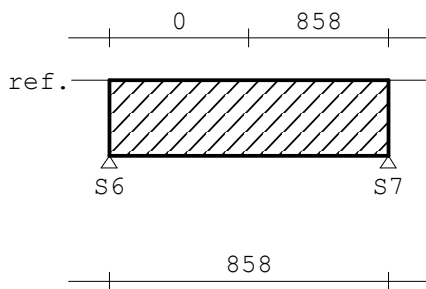

MEd dekkingslijn Fysisch lineair

Balk 2:wand as 4

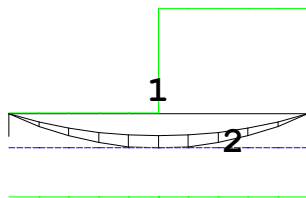

△
S6

△
S7

Hoofdwapening

Balk 2:wand as 4

Geb.	Vanaf [mm]	Tot [mm]	M_{Ed} [kNm]	M_{Rd} [kNm]	z B/O [mm]	A_b [mm ²]	A_a [mm ²]	Opm.	
1	S6+0	S7-0	-232.89	-568.99	1908	Ond	858*	858	2,54
2	S6+1700	S7-0	0.02	721.10	2418	Bov	858*	858	2,54

Opmerkingen

[2] Benodigde wapening en inwendige hefboomsarm zijn bepaald volgens gedrongen ligger detaillering, zie nationale bijlage art. 6.1(10).

Alle maten zijn zonder verschuiving van de m-lijn en verankering

[54] * = Eisen met betrekking tot minimum wapening ten behoeve van gecontroleerde scheurvorming zijn toegepast volgens art. 7.3.2.

Scheurvorming volgens artikel 7.3.4

Balk 2:wand as 4

Geb.	Pos. Zijde [mm]	$M_{E,freq}$ [kNm]	$s_{r,max}$ [mm]	$\epsilon_{sm}-\epsilon_{cm}$ [%]	w_k [mm]	k_x	w_{max} [mm]	U.C.	Opm.
1	S6+1700	Ond	-171.95	228	0.215	0.049	2.00	0.800	0.06

Project.....: 21038 - Herman Gorterstraat

DWARSKRACHTEN Fysisch lineair Balk 2:wand as 4 Fundamentele combinatie

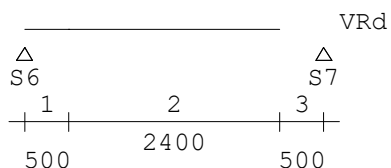
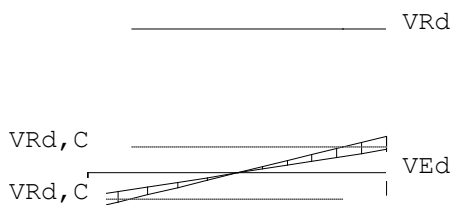

Wring- en dwarskrachtwapening

Balk 2:wand as 4

Geb.	Vanaf [mm]	Tot [mm]	Beugels	Lengte [mm]	<Wringing > <Dwarskr.>				V_{Ed} [kN]	T_{Ed} [kNm]	Opm.
					A_{lang} [mm ²]	A_{bg1} [mm ² /m]	A_{bg2} [mm ²]	A_{opg} [mm ²]			
1	S6+0	S6+500	Ø10-300	500	1	0	219	0	273.5	0	6,59
2	S6+500	S7-500	Ø10-300	2400	0	0	219	0	192.9	0	59
3	S7-500	S7-0	Ø10-300	500	1	0	219	0	273.5	0	6,59

Opmerkingen

[6] 9.2.2 (4) 50% van de dwarskrachtwapening moet uit beugels bestaan.

[59] 6.2.3: Z is berekend m.b.v. de gedrongen ligger berekening art 6.1 (10)

Wring- en dwarskrachten

Balk 2:wand as 4

Geb.	Vanaf [mm]	Tot [mm]	θ [°]	V_{Rd} [kN]	V_{Ed} [kN]	$V_{Rd,C}$ [kN]	$V_{Rd,Max}$ [kN]	T_{Ed} [kNm]	$T_{Rd,C}$ [kNm]	$T_{Rd,Max}$ [kNm]	V_{opg} [kN]	Opm.
1	S6+0	S6+500	21.8	1086	273	198	1737	0	119	322	0	6,59
2	S6+500	S7-500	21.8	1086	193	198	1737	0	119	322	0	59
3	S7-500	S7-0	21.8	1086	274	198	1737	0	119	322	0	6,59

Opmerkingen

[6] 9.2.2 (4) 50% van de dwarskrachtwapening moet uit beugels bestaan.

[59] 6.2.3: Z is berekend m.b.v. de gedrongen ligger berekening art 6.1 (10)

Hoofdwapening Fysisch lineair

Balk 3:wand as 2

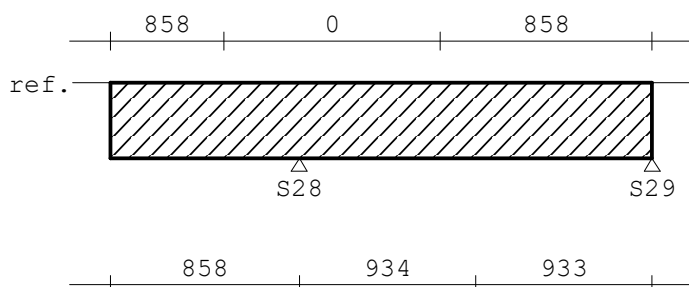

Project.....: 21038 - Herman Gorterstraat

MEd dekkingslijn Fysisch lineair

Balk 3:wand as 2

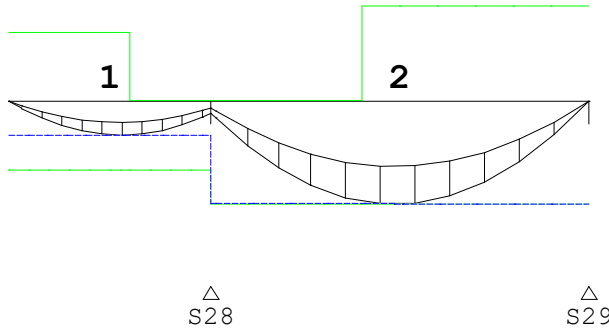

Hoofdwapening

Balk 3:wand as 2

Geb.	Vanaf [mm]	Tot [mm]	M _{Ed} [kNm]	M _{Rd} [kNm]	z B/O [mm]	A _b [mm ²]	A _a [mm ²]	Opm.	
1	S28-2299	S28+0	-233.57	-470.48	1577	Ond	858*	858	2,54
2	S28+0	S29-0	-706.29	-706.67	2178	Ond	934*	934	1,2

Opmerkingen

[1] * = Eisen met betrekking tot minimum wapening zijn toegepast, zie nationale bijlage art. 9.2.1.1(1).

[2] Benodigde wapening en inwendige hefboomsarm zijn bepaald volgens gedrongen ligger detaillering, zie nationale bijlage art. 6.1(10).

Alle maten zijn zonder verschuiving van de m-lijn en verankering

[54] * = Eisen met betrekking tot minimum wapening ten behoeve van gecontroleerde scheurvorming zijn toegepast volgens art. 7.3.2.

Scheurvorming volgens artikel 7.3.4

Balk 3:wand as 2

Geb.	Pos. [mm]	Zijde	M _{E;freq} [kNm]	s _{r,max} [mm]	ε _{sm} -ε _{cm} [%]	w _k [mm]	k _x	w _{max} [mm]	U.C.	Opm.
1	S28-1025	Ond	-171.98	228	0.215	0.049	2.00	0.800	0.06	
2	S28+2083	Ond	-520.61	222	0.765	0.170	2.00	0.800	0.21	

DWARSKRACHTEN Fysisch lineair

Balk 3:wand as 2 Fundamentele combinatie

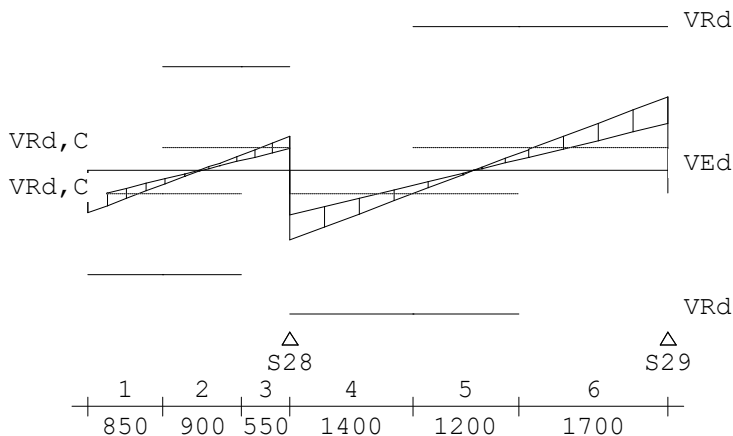

Project.....: 21038 - Herman Gorterstraat

Wring- en dwarskrachtwapening

Balk 3:wand as 2

Geb.	Vanaf	Tot	Beugels	Lengte	<Wringing >		<Dwarskr.>				
	[mm]	[mm]		[mm]	A_{lang}	A_{bg1}	A_{bg1}	A_{opg}	V_{Ed}	T_{Ed}	Opm.
					[mm ²]	[mm ² /m]	[mm ²]	[mm ²]	[kN]	[kNm]	
1	S28-2300	S28-1450	Ø10-300	850	2	0	219	0	365.6	0	6,59
2	S28-1450	S28-550	Ø10-300	900	0	0	219	0	135.8	0	59
3	S28-550	S28+0	Ø10-300	550	2	0	219	0	293.9	0	6,59
4	S28+0	S28+1400	Ø10-300	1400	2	0	253	0	598.0	0	6,59
5	S28+1400	S29-1700	Ø10-300	1200	0	0	219	0	195.6	0	59
6	S29-1700	S29-0	Ø10-300	1700	2	0	269	0	636.4	0	6,59

Opmerkingen

[6] 9.2.2 (4) 50% van de dwarskrachtwapening moet uit beugels bestaan.

[59] 6.2.3: Z is berekend m.b.v. de gedrongen ligger berekening art 6.1 (10)

Wring- en dwarskrachten

Balk 3:wand as 2

Geb.	Vanaf	Tot	θ	V_{Rd}	V_{Ed}	$V_{Rd,C}$	$V_{Rd,Max}$	T_{Ed}	$T_{Rd,C}$	$T_{Rd,Max}$	V_{opg}	Opm.
	[mm]	[mm]	[°]	[kN]	-----kN-----			-----kNm-----				
1	S28-2300	S28-1450	21.8	898	366	198	1436	0	119	322	0	6,59
2	S28-1450	S28-550	21.8	898	136	198	1436	0	119	322	0	59
3	S28-550	S28+0	21.8	898	294	198	1436	0	119	322	0	6,59
4	S28+0	S28+1400	21.8	1239	598	198	1983	0	119	322	0	6,59
5	S28+1400	S29-1700	21.8	1240	196	198	1983	0	119	322	0	59
6	S29-1700	S29-0	21.8	1239	636	198	1983	0	119	322	0	6,59

Opmerkingen

[6] 9.2.2 (4) 50% van de dwarskrachtwapening moet uit beugels bestaan.

[59] 6.2.3: Z is berekend m.b.v. de gedrongen ligger berekening art 6.1 (10)

Hoofdwapening Fysisch lineair

Balk 4:wand as 1

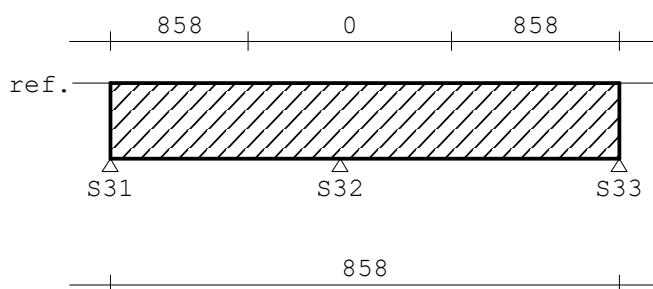

Project.....: 21038 - Herman Gorterstraat

MEd dekkingslijn Fysisch lineair

Balk 4:wand as 1

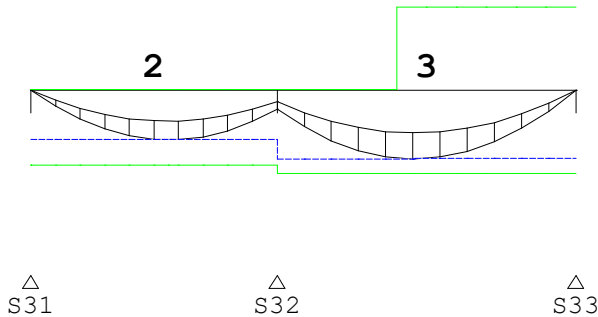

Hoofdwapening

Balk 4:wand as 1

Geb.	Vanaf [mm]	Tot [mm]	M_{Ed} [kNm]	M_{Rd} [kNm]	z B/O [mm]	A_b [mm ²]	A_a [mm ²]	Opm.
1	S31+0	S31+1	0.03	0.79	2 Bov	858*	858	2,54
2	S31+1	S32+0	-342.38	-515.21	1727 Ond	858*	858	2,54
3	S32+0	S33-0	-470.54	-568.99	1907 Ond	858*	858	2,54

Opmerkingen

[2] Benodigde wapening en inwendige hefboomsarm zijn bepaald volgens gedrongen ligger detaillering, zie nationale bijlage art. 6.1(10).

Alle maten zijn zonder verschuiving van de m-lijn en verankering

[54] * = Eisen met betrekking tot minimum wapening ten behoeve van gecontroleerde scheurvorming zijn toegepast volgens art. 7.3.2.

Scheurvorming volgens artikel 7.3.4

Balk 4:wand as 1

Geb.	Pos. [mm]	Zijde	$M_{E, freq}$ [kNm]	$s_{r, max}$ [mm]	$\epsilon_{sm} - \epsilon_{cm}$ [%]	w_k [mm]	k_x	w_{max} [mm]	U.C.	Opm.
2	S32-1231	Ond	-251.96	228	0.315	0.072	2.00	0.800	0.09	
3	S32+1561	Ond	-346.36	228	0.471	0.108	2.00	0.800	0.13	

DWARSKRACHTEN Fysisch lineair

Balk 4:wand as 1 Fundamentele combinatie

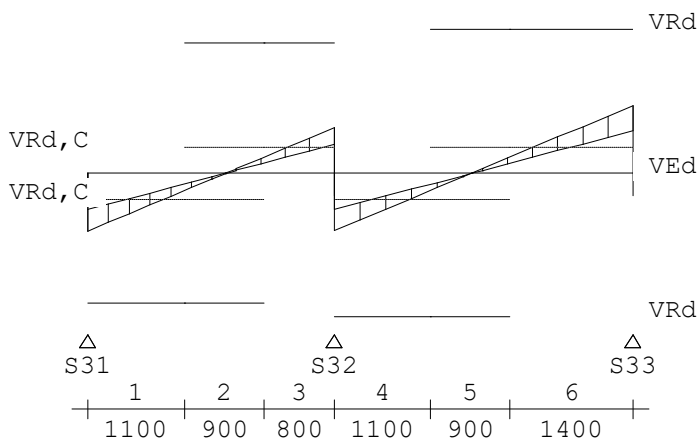

Project.....: 21038 - Herman Gorterstraat

Wring- en dwarskrachtwapening

Balk 4:wand as 1

Geb.	Vanaf [mm]	Tot [mm]	Beugels	Lengte [mm]	<Wringing >		<Dwarskr.>			Opm.	
					A_{lang} [mm ²]	A_{bg1} [mm ² /m]	A_{bg1} [mm ²]	A_{opg} [mm ²]	V_{Ed} [kN]		T_{Ed} [kNm]
1	S31+0	S31+1100	Ø10-300	1100	1	0	232	0	435.8	0	6,59
2	S31+1100	S32-800	Ø10-300	900	0	0	219	0	129.6	0	59
3	S32-800	S32+0	Ø10-300	800	1	0	219	0	341.9	0	6,59
4	S32+0	S32+1100	Ø10-300	1100	1	0	219	0	433.7	0	6,59
5	S32+1100	S33-1400	Ø10-300	900	0	0	219	0	127.5	0	59
6	S33-1400	S33-0	Ø10-300	1400	1	0	246	0	511.0	0	6,59

Opmerkingen

[6] 9.2.2 (4) 50% van de dwarskrachtwapening moet uit beugels bestaan.

[59] 6.2.3: Z is berekend m.b.v. de gedrongen ligger berekening art 6.1 (10)

Wring- en dwarskrachten

Balk 4:wand as 1

Geb.	Vanaf [mm]	Tot [mm]	θ [°]	V_{Rd} [kN]	V_{Ed}	$V_{Rd,C}$			T_{Ed}	$T_{Rd,C}$		V_{opg}	Opm.
						-----kN-----	-----kN-----	-----kN-----		-----kNm-----	-----kNm-----		
1	S31+0	S31+1100	21.8	983	436	198	1573	0	119	322	0	6,59	
2	S31+1100	S32-800	21.8	983	130	198	1573	0	119	322	0	59	
3	S32-800	S32+0	21.8	983	342	198	1573	0	119	322	0	6,59	
4	S32+0	S32+1100	21.8	1086	434	198	1737	0	119	322	0	6,59	
5	S32+1100	S33-1400	21.8	1086	128	198	1737	0	119	322	0	59	
6	S33-1400	S33-0	21.8	1086	511	198	1737	0	119	322	0	6,59	

Opmerkingen

[6] 9.2.2 (4) 50% van de dwarskrachtwapening moet uit beugels bestaan.

[59] 6.2.3: Z is berekend m.b.v. de gedrongen ligger berekening art 6.1 (10)

Hoofdwapening Fysisch lineair

Balk 5:wand as A

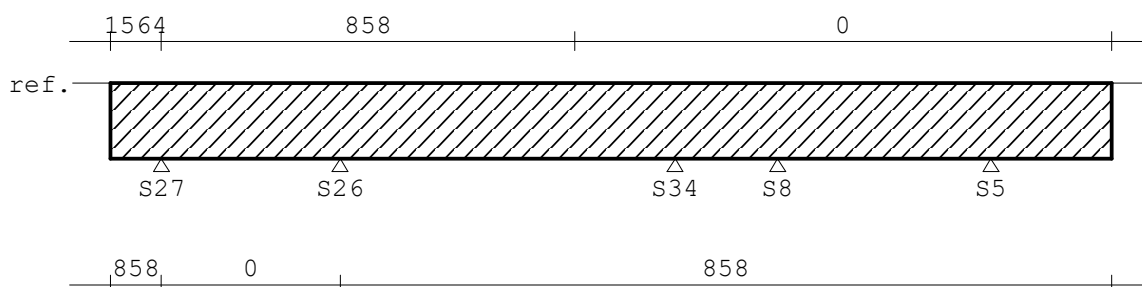

Project.....: 21038 - Herman Gorterstraat

MEd dekkingslijn Fysisch lineair

Balk 5:wand as A

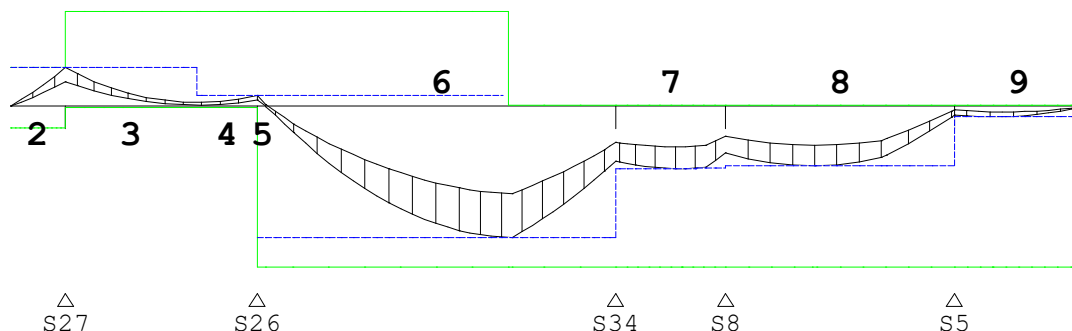
**Hoofdwapening**

Balk 5:wand as A

Geb.	Vanaf [mm]	Tot [mm]	M_{Ed} [kNm]	M_{Rd} [kNm]	z B/O [mm]	A_b [mm ²]	A_a [mm ²]	Opm.	
1	S27-620	S27-619	-0.02	-147.91	496	Ond	858*	858	2,54
2	S27-619	S27+0	269.57	269.65	496	Bov	1564*	1564	1,2
3	S27+0	S26-686	269.57	658.36	2207	Bov	858*	858	2,54
4	S26-686	S26+0	76.03	658.36	2207	Bov	858*	858	2,54
5	S26+0	S26+134	76.03	658.36	2207	Bov	858*	858	2,54
6	S26+102	S34+0	-908.34	-1111.11	2853	Ond	858*	858	2,54,68
7	S34+0	S8+0	-430.47	-1111.11	2853	Ond	858*	858	2,54,68
8	S8+0	S5+0	-411.71	-1111.11	2853	Ond	858*	858	2,54,68
9	S5+0	S5+1470	-72.75	-1111.11	2853	Ond	858*	858	2,54,68

Opmerkingen

[1] * = Eisen met betrekking tot minimum wapening zijn toegepast, zie nationale bijlage art. 9.2.1.1(1).

[2] Benodigde wapening en inwendige hefboomsarm zijn bepaald volgens gedrongen ligger detaillering, zie nationale bijlage art. 6.1(10).

Alle maten zijn zonder verschuiving van de m-lijn en verankering

[54] * = Eisen met betrekking tot minimum wapening ten behoeve van gecontroleerde scheurvorming zijn toegepast volgens art. 7.3.2.

[68] **MRd als gevolg van de gedrongen ligger berekening (NB. 6.1(10)) is groter dan MRd volgens 6.1(P). De momentweerstand en inwendige hefboomsarm volgens 6.1(P) zijn maatgevend en daarom alsnog toegepast.**

Scheurvorming volgens artikel 7.3.4

Balk 5:wand as A

Geb.	Pos. [mm]	Zijde	$M_{E,freq}$ [kNm]	$s_{r,max}$ [mm]	$\epsilon_{sm} - \epsilon_{cm}$ [%]	w_k [mm]	k_x	w_{max} [mm]	U.C.	Opm.
2	S27+0	Bov	198.73	211	0.138	0.029	2.00	0.800	0.04	
3	S27+0	Bov	198.73	228	0.248	0.057	2.00	0.800	0.07	
4	S26+0	Bov	53.75	228	0.067	0.015	2.00	0.800	0.02	
6	S34-1180	Ond	-672.63	228	1.151	0.263	2.00	0.800	0.33	
7	S8-493	Ond	-317.98	228	0.412	0.094	2.00	0.800	0.12	
8	S8+990	Ond	-304.49	228	0.384	0.088	2.00	0.800	0.11	
9	S5+429	Ond	-53.89	228	0.067	0.015	2.00	0.800	0.02	

Project.....: 21038 - Herman Gorterstraat

DWARSKRACHTEN Fysisch lineair Balk 5:wand as A Fundamentele combinatie

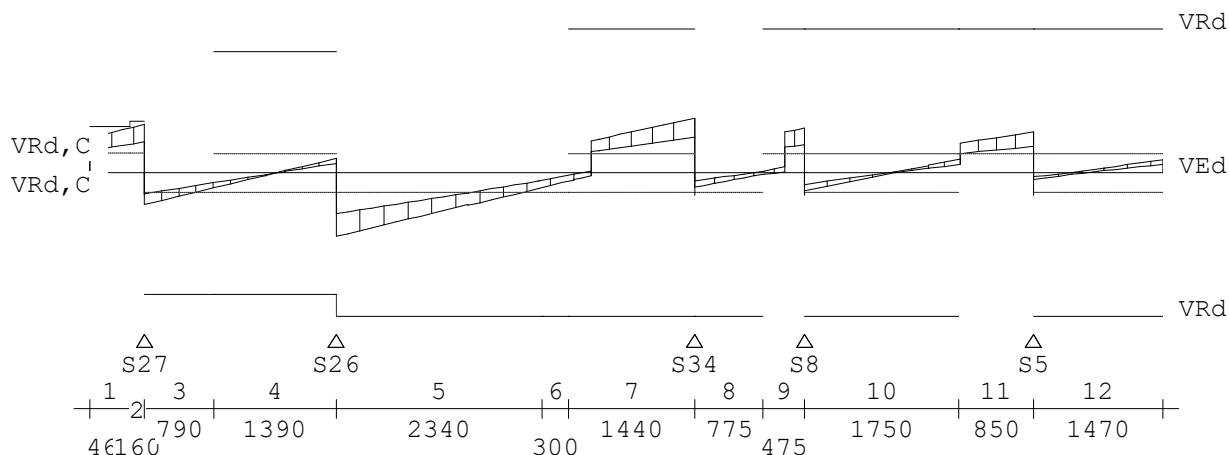

Wring- en dwarskrachtwapening Balk 5:wand as A

Geb.	Vanaf [mm]	Tot [mm]	Beugels	Lengte [mm]	<Wringing >			<Dwarskr.>		
					A_{lang} [mm ²]	A_{bg1} [mm ² /m]	A_{opg} [mm ²]	V_{Ed} [kN]	T_{Ed} [kNm]	Opm.
1	S27-620	S27-160	Ø10-150	460	1	0	1010	0	467.3	0 6,59
2	S27-160	S27+0	Ø10-100	160	1	0	1213	0	502.6	0 6,59
3	S27+0	S27+790	Ø10-300	790	1	0	219	0	329.7	0 6,59
4	S27+790	S26+0	Ø10-300	1390	0	0	219	0	155.4	0 59
5	S26+0	S34-1740	Ø10-300	2340	1	0	232	0	659.5	0 6,58
6	S34-1740	S34-1440	Ø10-300	300	0	0	219	0	154.4	0 58
7	S34-1440	S34+0	Ø10-300	1440	1	0	219	0	567.1	0 6,58
8	S34+0	S8-475	Ø10-300	775	0	0	219	0	147.2	0 58
9	S8-475	S8+0	Ø10-300	475	1	0	219	0	466.1	0 6,58
10	S8+0	S5-850	Ø10-300	1750	0	0	219	0	182.4	0 58
11	S5-850	S5+0	Ø10-300	850	0	0	219	0	423.8	0 6,58
12	S5+0	S5+1470	Ø10-300	1470	0	0	219	0	139.4	0 58

Opmerkingen

- [6] 9.2.2 (4) 50% van de dwarskrachtwapening moet uit beugels bestaan.
- [58] 6.2.3: Z is berekend m.b.v. 0.9d
- [59] 6.2.3: Z is berekend m.b.v. de gedrongen ligger berekening art 6.1 (10)

Wring- en dwarskrachten Balk 5:wand as A

Geb.	Vanaf [mm]	Tot [mm]	θ [°]	V_{Rd} [kN]	V_{Ed}	$V_{Rd,C}$	$V_{Rd,Max}$	T_{Ed}	$T_{Rd,C}$	$T_{Rd,Max}$	V_{opg}	Opm.
					-----kN-----			-----kNm-----				
1	S27-620	S27-160	25.0	484	467	205	502	0	119	357	0	6,59
2	S27-160	S27+0	27.5	536	503	205	536	0	119	382	0	6,59
3	S27+0	S27+790	21.8	1256	330	198	2010	0	119	322	0	6,59
4	S27+790	S26+0	21.8	1257	155	198	2010	0	119	322	0	59
5	S26+0	S34-1740	21.8	1490	660	198	2383	0	119	322	0	6,58
6	S34-1740	S34-1440	21.8	1490	154	198	2383	0	119	322	0	58
7	S34-1440	S34+0	21.8	1490	567	198	2383	0	119	322	0	6,58
8	S34+0	S8-475	21.8	1490	147	198	2383	0	119	322	0	58
9	S8-475	S8+0	21.8	1490	466	198	2383	0	119	322	0	6,58
10	S8+0	S5-850	21.8	1490	182	198	2383	0	119	322	0	58
11	S5-850	S5+0	21.8	1490	424	198	2383	0	119	322	0	6,58
12	S5+0	S5+1470	21.8	1490	139	198	2383	0	119	322	0	58

Project.....: 21038 - Herman Gorterstraat

Schuifspanningen

Balk 5:wand as A

Geb.	Vanaf [mm]	Tot [mm]	θ [°]	V_{Ed} [kN]	$v_{Rd,C}$	$v_{Rd,S}$	$V_{Ed} < v_{Rd} < v_{Rd,Max}$ [N/mm ²]	Opm.
------	---------------	-------------	-----------------	------------------	------------	------------	--	------

Opmerkingen

[6] 9.2.2 (4) 50% van de dwarskrachtwapening moet uit beugels bestaan.

[58] 6.2.3: Z is berekend m.b.v. 0.9d

[59] 6.2.3: Z is berekend m.b.v. de gedrongen ligger berekening art 6.1 (10)

Hoofdwapening Fysisch lineair

Balk 6:wand as B

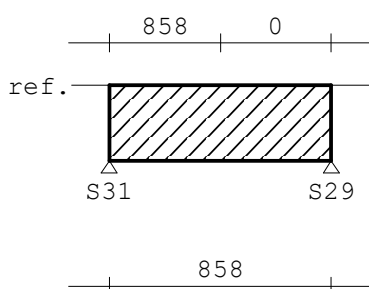

MEd dekkingslijn Fysisch lineair

Balk 6:wand as B

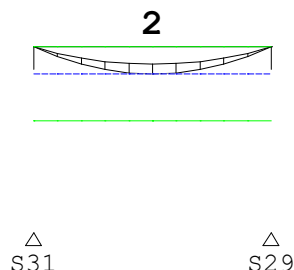

Hoofdwapening

Balk 6:wand as B

Geb.	Vanaf [mm]	Tot [mm]	M_{Ed} [kNm]	M_{Rd} [kNm]	z B/O [mm]	A_b [mm ²]	A_a [mm ²]	Opm.
1	S31+0	S31+1	0.02	0.78	2 Bov	858*	858	2,54
2	S31+1	S29+0	-184.06	-506.26	1697 Ond	858*	858	2,54

Opmerkingen

[2] Benodigde wapening en inwendige hefboomsarm zijn bepaald volgens gedrongen ligger detaillering, zie nationale bijlage art. 6.1(10).

Alle maten zijn zonder verschuiving van de m-lijn en verankering

[54] * = Eisen met betrekking tot minimum wapening ten behoeve van gecontroleerde scheurvorming zijn toegepast volgens art. 7.3.2.

Scheurvorming volgens artikel 7.3.4

Balk 6:wand as B

Geb.	Pos. Zijde [mm]	$M_{E,freq}$ [kNm]	$s_{r,max}$ [mm]	$\epsilon_{sm}-\epsilon_{cm}$ [%]	w_k [mm]	k_x	w_{max} [mm]	U.C.	Opm.
2	S31+1350	Ond	-135.78	228	0.170	0.039	2.00	0.800	0.05

Project.....: 21038 - Herman Gorterstraat

DWARSKRACHTEN Fysisch lineair Balk 6:wand as B Fundamentele combinatie

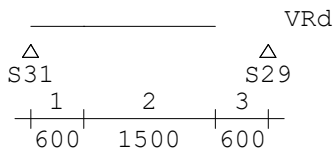
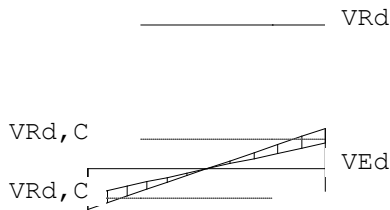

Wring- en dwarskrachtwapening

Balk 6:wand as B

Geb.	Vanaf	Tot	Beugels	Lengte <Wringing > <Dwarskr.>	A_{lang}	A_{bg1}	A_{bg1}	A_{opg}	V_{Ed}	T_{Ed}	Opm.
	[mm]	[mm]		[mm]	[mm ²]	[mm ² /m]	[mm ²]		[kN]	[kNm]	
1	S31+0	S31+600	Ø10-300	600	2	0	219	0	272.1	0	6,59
2	S31+600	S29-600	Ø10-300	1500	0	0	219	0	150.9	0	59
3	S29-600	S29+0	Ø10-300	600	2	0	219	0	272.0	0	6,59

Opmerkingen

[6] 9.2.2 (4) 50% van de dwarskrachtwapening moet uit beugels bestaan.

[59] 6.2.3: Z is berekend m.b.v. de gedrongen ligger berekening art 6.1 (10)

Wring- en dwarskrachten

Balk 6:wand as B

Geb.	Vanaf	Tot	θ	V_{Rd}	V_{Ed}	$V_{Rd,C}$	$V_{Rd,Max}$	T_{Ed}	$T_{Rd,C}$	$T_{Rd,Max}$	V_{opg}	Opm.
	[mm]	[mm]	[°]	[kN]								
				-----kN-----				-----kNm-----				
1	S31+0	S31+600	21.8	966	272	198	1545	0	119	322	0	6,59
2	S31+600	S29-600	21.8	966	151	198	1545	0	119	322	0	59
3	S29-600	S29+0	21.8	966	272	198	1545	0	119	322	0	6,59

Opmerkingen

[6] 9.2.2 (4) 50% van de dwarskrachtwapening moet uit beugels bestaan.

[59] 6.2.3: Z is berekend m.b.v. de gedrongen ligger berekening art 6.1 (10)

Hoofdwapening Fysisch lineair

Balk 7:wand as C

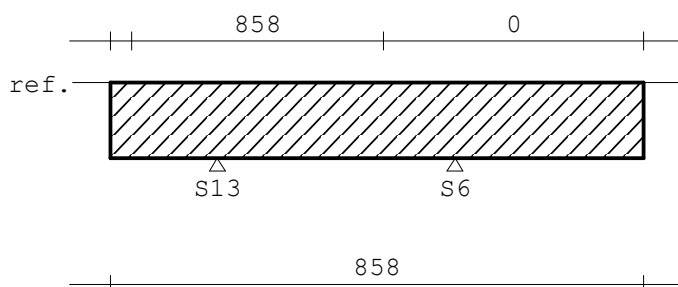

Project.....: 21038 - Herman Gorterstraat

MEd dekkingslijn Fysisch lineair

Balk 7:wand as C

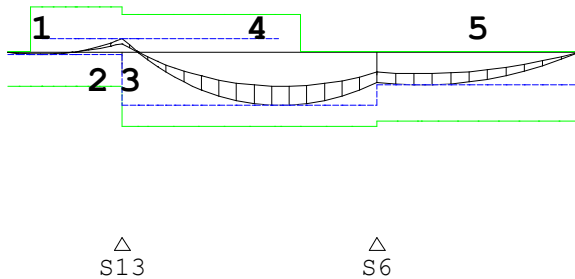

Hoofdwapening

Balk 7:wand as C

Geb.	Vanaf [mm]	Tot [mm]	M _{Ed} [kNm]	M _{Rd} [kNm]	z B/O [mm]		A _b [mm ²]	A _a [mm ²]	Opm.
1	S13-1300	S13-526	-19.63	-232.60	779	Ond	858*	858	2,54
2	S13-531	S13+0	90.76	310.14	1039	Bov	858*	858	2,54
3	S13+0	S13+179	90.76	253.84	851	Bov	858*	858	2,54
4	S13+177	S6-0	-367.18	-508.41	1704	Ond	858*	858	2,54
5	S6-0	S6+2300	-226.82	-470.58	1577	Ond	858*	858	2,54

Opmerkingen

[2] Benodigde wapening en inwendige hefboomsarm zijn bepaald volgens gedrongen ligger detaillering, zie nationale bijlage art. 6.1(10).

Alle maten zijn zonder verschuiving van de m-lijn en verankering

[54] * = Eisen met betrekking tot minimum wapening ten behoeve van gecontroleerde scheurvorming zijn toegepast volgens art. 7.3.2.

Scheurvorming volgens artikel 7.3.4

Balk 7:wand as C

Geb.	Pos. [mm]	Zijde	M _{E, freq} [kNm]	s _{r, max} [mm]	ε _{sm} -ε _{cm} [%]	w _k [mm]	k _x	w _{max} [mm]	U.C.	Opm.
1	S13-914	Ond	-14.46	228	0.018	0.004	2.00	0.800	0.01	
2	S13+0	Bov	66.87	228	0.084	0.019	2.00	0.800	0.02	
4	S6-1095	Ond	-270.86	228	0.339	0.077	2.00	0.800	0.10	
5	S6+506	Ond	-167.76	228	0.210	0.048	2.00	0.800	0.06	

DWARSKRACHTEN Fysisch lineair

Balk 7:wand as C Fundamentele combinatie

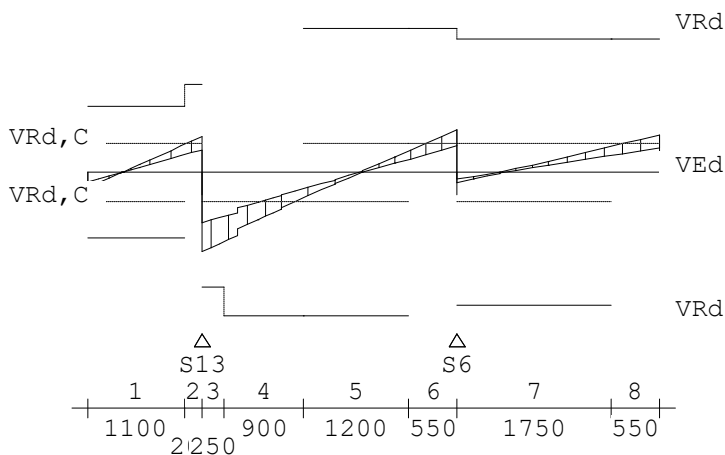

Project.....: 21038 - Herman Gorterstraat

Wring- en dwarskrachtwapening

Balk 7:wand as C

Geb.	Vanaf [mm]	Tot [mm]	Beugels	Lengte [mm]	<Wringing >		<Dwarskr.>		V _{Ed} [kN]	T _{Ed} [kNm]	Opm.
					A _{lang} [mm ²]	A _{bg1} [mm ² /m]	A _{bg1} [mm ²]	A _{opg} [mm ²]			
1	S13-1300	S13-200	Ø10-300	1100	0	0	219	0	187.9	0	59
2	S13-200	S13+0	Ø10-300	200	1	0	219	0	240.7	0	6,59
3	S13+0	S13+250	Ø10-150	250	1	0	576	0	533.4	0	6,59
4	S13+250	S13+1150	Ø10-300	900	1	0	252	0	467.4	0	6,59
5	S13+1150	S6-550	Ø10-300	1200	0	0	219	0	172.1	0	59
6	S6-550	S6-0	Ø10-300	550	1	0	219	0	288.4	0	6,59
7	S6-0	S6+1750	Ø10-300	1750	0	0	219	0	174.9	0	59
8	S6+1750	S6+2300	Ø10-300	550	0	0	219	0	252.4	0	6,59

Opmerkingen

[6] 9.2.2 (4) 50% van de dwarskrachtwapening moet uit beugels bestaan.

[59] 6.2.3: Z is berekend m.b.v. de gedrongen ligger berekening art 6.1 (10)

Wring- en dwarskrachten

Balk 7:wand as C

Geb.	Vanaf [mm]	Tot [mm]	θ [°]	V _{Rd} [kN]	V _{Ed} V _{Rd,C} V _{Rd,Max}			T _{Ed} T _{Rd,C} T _{Rd,Max}			V _{opg}	Opm.
					-----kN-----	-----kN-----	-----kN-----	-----kNm-----	-----kNm-----	-----kNm-----		
1	S13-1300	S13-200	21.8	592	188	198	710	0	119	322	0	59
2	S13-200	S13+0	21.8	592	241	198	947	0	119	322	0	6,59
3	S13+0	S13+250	21.8	775	533	198	775	0	119	322	0	6,59
4	S13+250	S13+1150	21.8	970	467	198	1552	0	119	322	0	6,59
5	S13+1150	S6-550	21.8	970	172	198	1552	0	119	322	0	59
6	S6-550	S6-0	21.8	970	288	198	1552	0	119	322	0	6,59
7	S6-0	S6+1750	21.8	898	175	198	1436	0	119	322	0	59
8	S6+1750	S6+2300	21.8	898	252	198	1436	0	119	322	0	6,59

Opmerkingen

[6] 9.2.2 (4) 50% van de dwarskrachtwapening moet uit beugels bestaan.

[59] 6.2.3: Z is berekend m.b.v. de gedrongen ligger berekening art 6.1 (10)

Hoofdwapening Fysisch lineair

Balk 8:wand as E

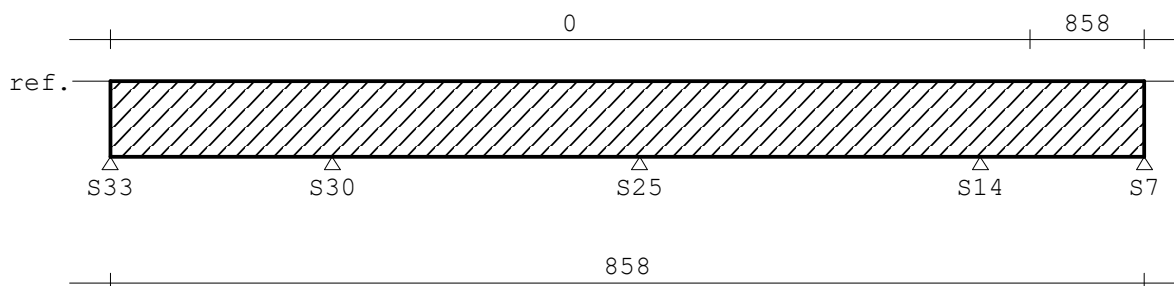

Project.....: 21038 - Herman Gorterstraat

MEd dekkingslijn Fysisch lineair

Balk 8:wand as E

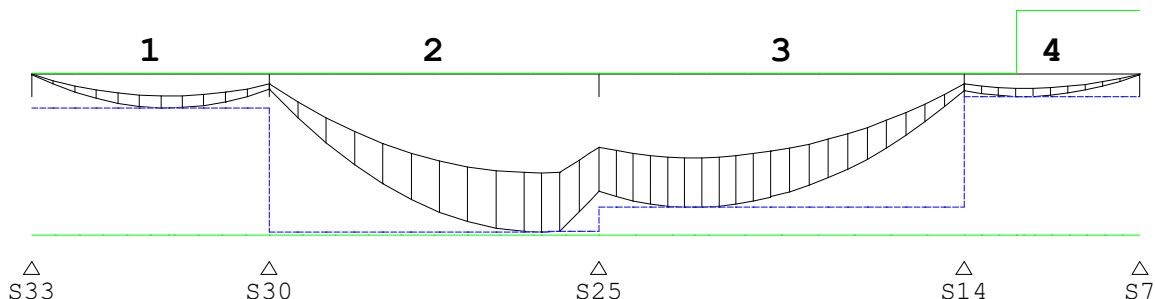
**Hoofdwapening**

Balk 8:wand as E

Geb.	Vanaf [mm]	Tot [mm]	M_{Ed} [kNm]	M_{Rd} [kNm]	z [mm]	B/O	A_b [mm ²]	A_a [mm ²]	Opm.
1	S33+0	S30+0	-232.38	-1111.11	2853	Ond	858*	858	2,54,68
2	S30+0	S25+0	-1090.34	-1111.11	2853	Ond	858*	858	2,54,68
3	S25+0	S14+0	-921.76	-1111.11	2853	Ond	858*	858	2,54,68
4	S14+0	S7+0	-153.23	-1111.11	2853	Ond	858*	858	2,54,68

Opmerkingen

[2] Benodigde wapening en inwendige hefboomsarm zijn bepaald volgens gedrongen ligger detaillering, zie nationale bijlage art. 6.1(10).

Alle maten zijn zonder verschuiving van de m-lijn en verankering

[54] * = Eisen met betrekking tot minimum wapening ten behoeve van gecontroleerde scheurvorming zijn toegepast volgens art. 7.3.2.

[68] **MRd als gevolg van de gedrongen ligger berekening (NB. 6.1(10)) is groter dan MRd volgens 6.1(P). De momentweerstand en inwendige hefboomsarm volgens 6.1(P) zijn maatgevend en daarom alsnog toegepast.**

Scheurvorming volgens artikel 7.3.4

Balk 8:wand as E

Geb.	Pos. [mm]	Zijde	$M_{E,freq}$ [kNm]	$s_{r,max}$ [mm]	$\epsilon_{sm}-\epsilon_{cm}$ [%]	w_k [mm]	k_x	w_{max} [mm]	U.C.	Opm.
1	S30-1146	Ond	-171.57	228	0.214	0.049	2.00	0.800	0.06	
2	S25-655	Ond	-802.63	228	1.421	0.325	2.00	0.800	0.41	
3	S25+1080	Ond	-678.68	228	1.163	0.266	2.00	0.800	0.33	
4	S14+684	Ond	-112.79	228	0.141	0.032	2.00	0.800	0.04	

Project.....: 21038 - Herman Gorterstraat

DWARSKRACHTEN Fysisch lineair Balk 8:wand as E Fundamentele combinatie

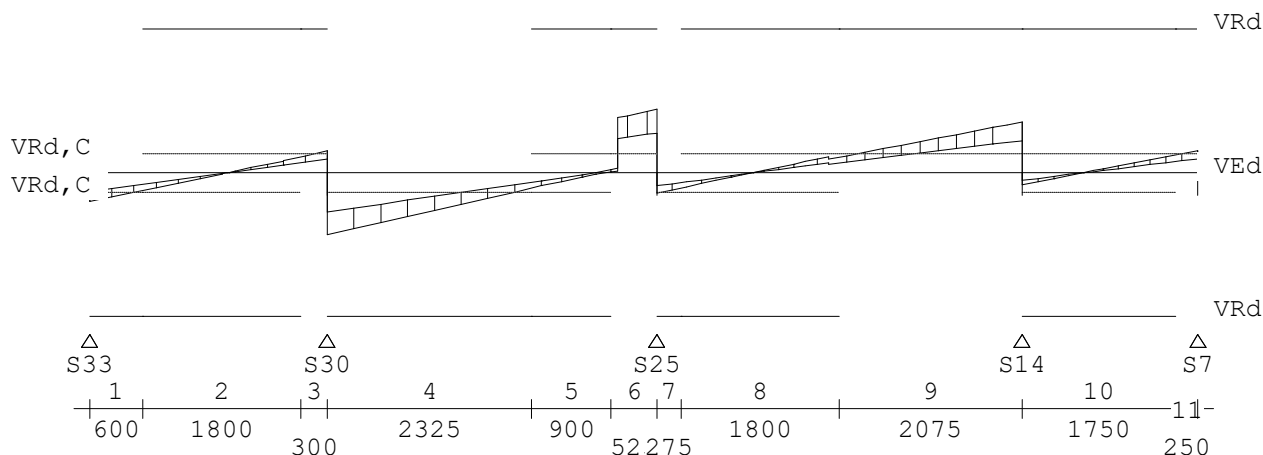

Wring- en dwarskrachtwapening Balk 8:wand as E

Geb.	Vanaf [mm]	Tot [mm]	Beugels	Lengte [mm]	<Wringing >			<Dwarskr.>		
					A_{lang} [mm ²]	A_{bg1} [mm ² /m]	A_{opg} [mm ²]	V_{Ed} [kN]	T_{Ed} [kNm]	Opm.
1	S33+0	S33+600	Ø10-300	600	1	0	219	0	298.4	0 6,58
2	S33+600	S30-300	Ø10-300	1800	0	0	219	0	183.0	0 58
3	S30-300	S30+0	Ø10-300	300	1	0	219	0	227.5	0 6,58
4	S30+0	S25-1425	Ø10-300	2325	1	0	225	0	639.4	0 6,58
5	S25-1425	S25-525	Ø10-300	900	0	0	219	0	156.4	0 58
6	S25-525	S25+0	Ø10-300	525	2	0	231	0	657.6	0 6,58
7	S25+0	S25+275	Ø10-300	275	2	0	219	0	207.1	0 6,58
8	S25+275	S25+2075	Ø10-300	1800	0	0	219	0	167.4	0 58
9	S25+2075	S14+0	Ø10-300	2075	2	0	219	0	529.1	0 6,58
10	S14+0	S7-250	Ø10-300	1750	0	0	219	0	188.1	0 58
11	S7-250	S7+0	Ø10-300	250	2	0	219	0	232.3	0 6,58

Opmerkingen

[6] 9.2.2 (4) 50% van de dwarskrachtwapening moet uit beugels bestaan.

[58] 6.2.3: z is berekend m.b.v. 0.9d

Wring- en dwarskrachten Balk 8:wand as E

Geb.	Vanaf [mm]	Tot [mm]	θ [°]	V_{Rd} [kN]	V_{Ed}	$V_{Rd,C}$	$V_{Rd,Max}$	T_{Ed}	$T_{Rd,C}$	$T_{Rd,Max}$	V_{opg}	Opm.
				-----kN-----			-----kNm-----					
1	S33+0	S33+600	21.8	1490	298	198	2383	0	119	322	0	6,58
2	S33+600	S30-300	21.8	1490	183	198	2383	0	119	322	0	58
3	S30-300	S30+0	21.8	1490	227	198	2383	0	119	322	0	6,58
4	S30+0	S25-1425	21.8	1490	639	198	2383	0	119	322	0	6,58
5	S25-1425	S25-525	21.8	1490	156	198	2383	0	119	322	0	58
6	S25-525	S25+0	21.8	1490	658	198	2383	0	119	322	0	6,58
7	S25+0	S25+275	21.8	1490	207	198	2383	0	119	322	0	6,58
8	S25+275	S25+2075	21.8	1490	167	198	2383	0	119	322	0	58
9	S25+2075	S14+0	21.8	1490	529	198	2383	0	119	322	0	6,58
10	S14+0	S7-250	21.8	1490	188	198	2383	0	119	322	0	58
11	S7-250	S7+0	21.8	1490	232	198	2383	0	119	322	0	6,58

Project.....: 21038 - Herman Gorterstraat

Schuifspanningen

Balk 8:wand as E

Geb.	Vanaf [mm]	Tot [mm]	θ [°]	V_{Ed} [kN]	$v_{Rd,C}$	$v_{Rd,S}$	$V_{Ed} < v_{Rd} < v_{Rd,Max}$ [N/mm ²]	Opm.
------	---------------	-------------	-----------------	------------------	------------	------------	--	------

Opmerkingen

[6] 9.2.2 (4) 50% van de dwarskrachtwapening moet uit beugels bestaan.

[58] 6.2.3: Z is berekend m.b.v. 0.9d

Hoofdwapening Fysisch lineair

Balk 9:wand as 4'

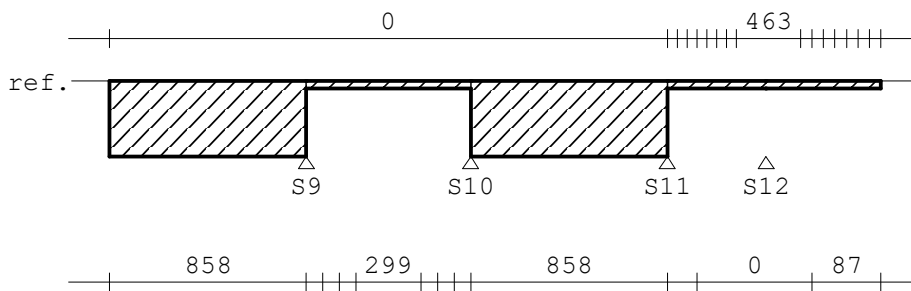

MEd dekkingslijn Fysisch lineair

Balk 9:wand as 4'

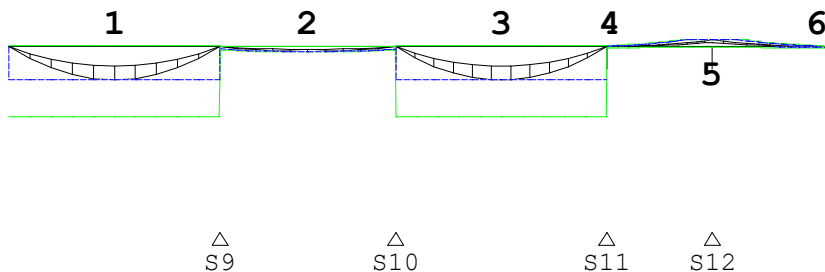

Hoofdwapening

Balk 9:wand as 4'

Geb.	Vanaf [mm]	Tot [mm]	M_{Ed} [kNm]	M_{Rd} [kNm]	z [mm]	B/O	A_b [mm ²]	A_a [mm ²]	Opm.
1	S9-2400	S9+0	-226.80	-479.52	1608	Ond	858*	858	2,54
2	S9+0	S10+0	-32.17	-32.18	237	Ond	299	299	
3	S10+0	S11+0	-226.80	-479.52	1608	Ond	858*	858	2,54
5	S11+0	S12+1177	47.37	47.37	229	Bov	463	463	
6	S12+971	S12+1400	-1.23	-7.78	245	Ond	87*	87	54

Opmerkingen

[2] Benodigde wapening en inwendige hefboomsarm zijn bepaald volgens gedrongen ligger detaillering, zie nationale bijlage art. 6.1(10).

Alle maten zijn zonder verschuiving van de m-lijn en verankering

[54] * = Eisen met betrekking tot minimum wapening ten behoeve van gecontroleerde scheurvorming zijn toegepast volgens art. 7.3.2.

Project.....: 21038 - Herman Gorterstraat

Scheurvorming volgens artikel 7.3.4

Balk 9:wand as 4'

Geb.	Pos. [mm]	Zijde	$M_E; freq$ [kNm]	$S_{r, max}$ [mm]	$\epsilon_{sm} - \epsilon_{cm}$ [%]	w_k [mm]	k_x	w_{max} [mm]	U.C.	Opm.
1	S9-1200	Ond	-165.24	228	0.207	0.047	2.00	0.800	0.06	
2	S9+1000	Ond	-22.69	286	1.195	0.342	2.00	0.800	0.43	
3	S10+1200	Ond	-165.24	228	0.207	0.047	2.00	0.800	0.06	
5	S12+0	Bov	34.87	232	1.363	0.317	2.00	0.800	0.40	
6	S12+1205	Ond	-0.52	350	0.074	0.026	2.00	0.800	0.03	

DWARSKRACHTEN Fysisch lineair

Balk 9:wand as 4' Fundamentele combinatie

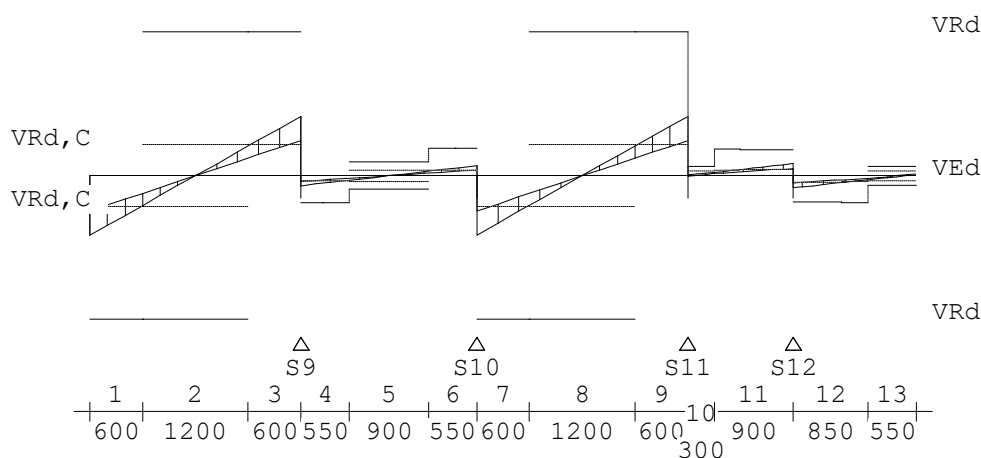

Wring- en dwarskrachtwapening

Balk 9:wand as 4'

Geb.	Vanaf [mm]	Tot [mm]	Beugels	Lengte [mm]	<Wringing >				<Dwarskr.>	V_{Ed} [kN]	T_{Ed} [kNm]	Opm.
					A_{lang} [mm ²]	A_{bgl} [mm ² /m]	A_{bgl} [mm ²]	A_{opg} [mm ²]				
1	S9-2400	S9-1800	Ø10-300	600	0	0	219	0	377.1	0	6,59	
2	S9-1800	S9-600	Ø10-300	1200	0	0	219	0	188.1	0	59	
3	S9-600	S9+0	Ø10-300	600	0	0	219	0	377.1	0	6,59	
4	S9+0	S9+550	Ø8-150	550	0	0	248	0	64.2	0	6	
5	S9+550	S10-550	Ø8-300	900	0	0	219	0	28.8	0		
6	S10-550	S10+0	Ø8-150	550	0	0	248	0	64.2	0	6	
7	S10+0	S10+600	Ø10-300	600	0	0	219	0	377.1	0	6,59	
8	S10+600	S11-600	Ø10-300	1200	0	0	219	0	188.1	0	59	
9	S11-600	S11+0	Ø10-300	600	0	0	219	0	377.1	0	6,59	
10	S11+0	S11+300	Ø8-300	300	0	0	219	0	20.7	0		
11	S11+300	S12+0	Ø8-150	900	0	0	306	0	76.5	0	6	
12	S12+0	S12+850	Ø8-150	850	0	0	310	0	77.3	0	6	
13	S12+850	S12+1400	Ø8-300	550	0	0	219	0	24.3	0		

Project.....: 21038 - Herman Gorterstraat

Dwarskrachtwapening

Balk 9:wand as 4'

Geb.	Vanaf [mm]	Tot [mm]	Beugels	Lengte [mm]	A_{sw} [mm ² /m]	V_{Ed} [kN]	A_{opg} [mm ²]	Opm.
------	---------------	-------------	---------	----------------	----------------------------------	------------------	---------------------------------	------

Opmerkingen

[6] 9.2.2 (4) 50% van de dwarskrachtwapening moet uit beugels bestaan.

[59] 6.2.3: Z is berekend m.b.v. de gedrongen ligger berekening art 6.1 (10)

Wring- en dwarskrachten

Balk 9:wand as 4'

Geb.	Vanaf [mm]	Tot [mm]	θ [°]	V_{Rd} [kN]	V_{Ed}	$V_{Rd,C}$	$V_{Rd,Max}$	T_{Ed}	$T_{Rd,C}$	$T_{Rd,Max}$	V_{opg}	Opm.
				-----kN-----			-----kNm-----					
1	S9-2400	S9-1800	21.8	915	377	198	1464	0	119	322	0	6,59
2	S9-1800	S9-600	21.8	915	188	198	1464	0	119	322	0	59
3	S9-600	S9+0	21.8	915	377	198	1464	0	119	322	0	6,59
4	S9+0	S9+550	21.8	174	64	33	217	0	8	22	0	6
5	S9+550	S10-550	21.8	86	29	35	216	0	8	22	0	
6	S10-550	S10+0	21.8	174	64	33	217	0	8	22	0	6
7	S10+0	S10+600	21.8	915	377	198	1464	0	119	322	0	6,59
8	S10+600	S11-600	21.8	915	188	198	1464	0	119	322	0	59
9	S11-600	S11+0	21.8	915	377	198	1464	0	119	322	0	6,59
10	S11+0	S11+300	21.8	59	21	31	147	0	8	22	0	
11	S11+300	S12+0	21.8	167	77	40	209	0	8	22	0	6
12	S12+0	S12+850	21.8	167	77	40	209	0	8	22	0	6
13	S12+850	S12+1400	21.8	59	24	31	147	0	8	22	0	

Opmerkingen

[6] 9.2.2 (4) 50% van de dwarskrachtwapening moet uit beugels bestaan.

[59] 6.2.3: Z is berekend m.b.v. de gedrongen ligger berekening art 6.1 (10)

Hoofdwapening Fysisch lineair

Balk 10:wand as 3

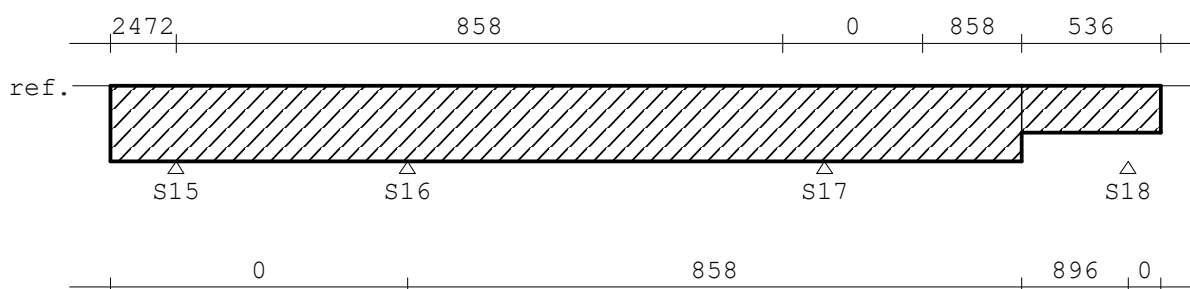

Project.....: 21038 - Herman Gorterstraat

MEd dekkingslijn Fysisch lineair

Balk 10:wand as 3

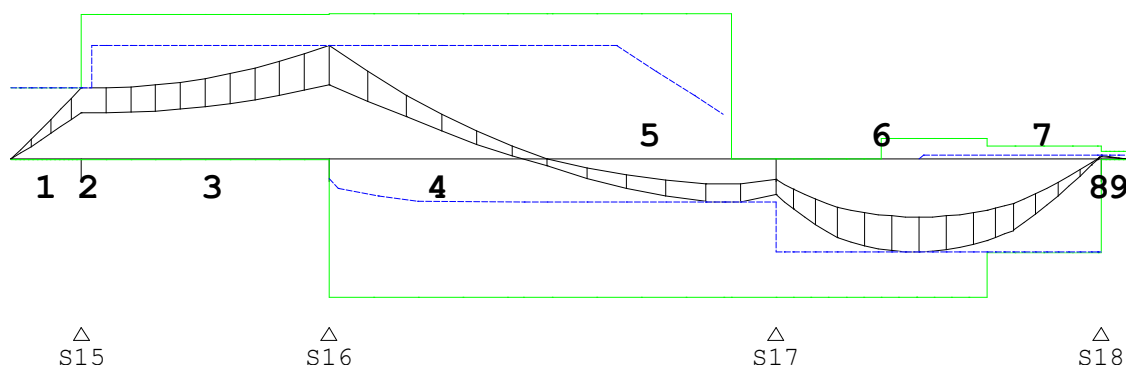
**Hoofdwapening**

Balk 10:wand as 3

Geb.	Vanaf [mm]	Tot [mm]	M_{Ed} [kNm]	M_{Rd} [kNm]	z B/O [mm]	A_b [mm ²]	A_a [mm ²]	Opm.	
1	S15-800	S15+0	550.01	550.12	640	Bov	2472*	2472	1,2
2	S15+0	S15+177	550.01	1111.11	2853	Bov	858*	858	2,54,68
3	S15+177	S16+0	875.64	1111.11	2853	Bov	858*	858	2,54,68
4	S16+0	S16+2481	875.64	1111.11	2853	Bov	858*	858	2,54,68
5	S16+2212	S17+0	-332.57	-1061.34	2847	Ond	858*	858	2,54
6	S17+0	S18-1300	-711.97	-1061.34	2847	Ond	858*	858	2,54
7	S18-1300	S18-37	-711.91	-711.91	1750	Ond	896	896	2,68
8	S18-45	S18+0	29.13	99.59	534	Bov	536*	536	2,54
9	S18+0	S18+400	29.13	59.64	320	Bov	536*	536	2,54

Opmerkingen

[1] * = Eisen met betrekking tot minimum wapening zijn toegepast, zie nationale bijlage art. 9.2.1.1(1).

[2] Benodigde wapening en inwendige hefboomsarm zijn bepaald volgens gedrongen ligger detaillering, zie nationale bijlage art. 6.1(10).

Alle maten zijn zonder verschuiving van de m-lijn en verankering

[54] * = Eisen met betrekking tot minimum wapening ten behoeve van gecontroleerde scheurvorming zijn toegepast volgens art. 7.3.2.

[68] **MRd als gevolg van de gedrongen ligger berekening (NB. 6.1(10)) is groter dan MRd volgens 6.1(P). De momentweerstand en inwendige hefboomsarm volgens 6.1(P) zijn maatgevend en daarom alsnog toegepast.**

[93] De wapening bij de doorsnede overgang is niet getoetst vlg. NEN-EN 1992-1-1 art.9.9.

Scheurvorming volgens artikel 7.3.4

Balk 10:wand as 3

Geb.	Pos. [mm]	Zijde	$M_{E,freq}$ [kNm]	$s_{r,max}$ [mm]	$\epsilon_{sm} - \epsilon_{cm}$ [%]	w_k [mm]	k_x	w_{max} [mm]	U.C.	Opm.
1	S15+0	Bov	406.23	190	0.191	0.036	2.00	0.800	0.05	
2	S15+0	Bov	406.23	228	0.596	0.136	2.00	0.800	0.17	
3	S16+0	Bov	647.16	228	1.097	0.251	2.00	0.800	0.31	
5	S17-594	Ond	-239.14	228	0.299	0.068	2.00	0.800	0.09	
6	S17+1602	Ond	-523.92	228	0.841	0.192	2.00	0.800	0.24	
7	S18-1300	Ond	-459.30	225	1.256	0.283	2.00	0.800	0.35	
8	S18+0	Bov	21.58	274	0.070	0.019	2.00	0.800	0.02	

Project.....: 21038 - Herman Gorterstraat

DWARSKRACHTEN Fysisch lineair Balk 10:wand as 3 Fundamentele combinatie

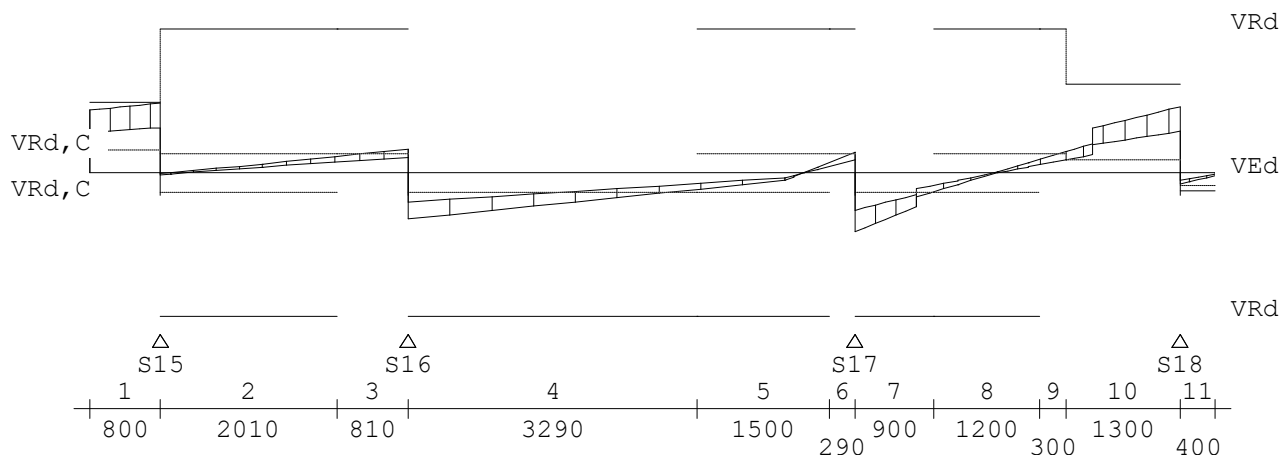

Wring- en dwarskrachtwapening

Balk 10:wand as 3

Geb.	Vanaf [mm]	Tot [mm]	Beugels	Lengte [mm]	<Wringing >			<Dwarskr.>		
					$A_{l\text{angs}}$ [mm ²]	A_{bgl} [mm ² /m]	A_{opg} [mm ²]	V_{Ed} [kN]	T_{Ed} [kNm]	Opm.
1	S15-800	S15+0	Ø10-100	800	0	0	1504	0	724.7	0 6,59
2	S15+0	S16-810	Ø10-300	2010	0	0	219	0	171.4	0 58
3	S16-810	S16+0	Ø10-300	810	0	0	219	0	247.3	0 6,58
4	S16+0	S17-1790	Ø10-300	3290	0	0	219	0	479.1	0 6,58
5	S17-1790	S17-290	Ø10-300	1500	0	0	219	0	170.9	0 58
6	S17-290	S17+0	Ø10-300	290	0	0	219	0	214.8	0 6,58
7	S17+0	S17+900	Ø10-300	900	0	0	219	0	607.9	0 6,58
8	S17+900	S18-1600	Ø10-300	1200	0	0	219	0	193.4	0 58
9	S18-1600	S18-1300	Ø10-300	300	0	0	219	0	219.9	0 6,58
10	S18-1300	S18+0	Ø10-300	1300	0	0	390	0	685.7	0 6,58
11	S18+0	S18+400	Ø10-300	400	0	0	219	0	115.9	0 59

Opmerkingen

- [6] 9.2.2 (4) 50% van de dwarskrachtwapening moet uit beugels bestaan.
- [58] 6.2.3: Z is berekend m.b.v. 0.9d
- [59] 6.2.3: Z is berekend m.b.v. de gedrongen ligger berekening art 6.1 (10)

Wring- en dwarskrachten

Balk 10:wand as 3

Geb.	Vanaf [mm]	Tot [mm]	θ [°]	V_{Rd} [kN]	V_{Ed}	$V_{Rd,C}$	$V_{Rd,Max}$	T_{Ed}	$T_{Rd,C}$	$T_{Rd,Max}$	V_{Opg}	Opm.
				-----kN-----			-----kNm-----					
1	S15-800	S15+0	30.0	732	725	239	732	0	119	404	0	6,59
2	S15+0	S16-810	21.8	1490	171	198	2383	0	119	322	0	58
3	S16-810	S16+0	21.8	1490	247	198	2383	0	119	322	0	6,58
4	S16+0	S17-1790	21.8	1490	479	198	2383	0	119	322	0	6,58
5	S17-1790	S17-290	21.8	1490	171	198	2383	0	119	322	0	58
6	S17-290	S17+0	21.8	1490	215	198	2383	0	119	322	0	6,58
7	S17+0	S17+900	21.8	1490	608	198	2383	0	119	322	0	6,58
8	S17+900	S18-1600	21.8	1490	193	198	2383	0	119	322	0	58
9	S18-1600	S18-1300	21.8	1490	220	198	2383	0	119	322	0	6,58
10	S18-1300	S18+0	21.8	922	686	133	1474	0	72	195	0	6,58
11	S18+0	S18+400	21.8	182	116	133	291	0	72	195	0	59

Project.....: 21038 - Herman Gorterstraat

Schuifspanningen

Balk 10:wand as 3

Geb.	Vanaf [mm]	Tot [mm]	θ [°]	V_{Ed} [kN]	$v_{Rd,C}$	$v_{Rd,S}$	$v_{Ed} < v_{Rd} < v_{Rd,Max}$ [N/mm ²]	Opm.
------	---------------	-------------	-----------------	------------------	------------	------------	--	------

Opmerkingen

[6] 9.2.2 (4) 50% van de dwarskrachtwapening moet uit beugels bestaan.

[58] 6.2.3: Z is berekend m.b.v. 0.9d

[59] 6.2.3: Z is berekend m.b.v. de gedrongen ligger berekening art 6.1 (10)

Hoofdwapening Fysisch lineair

Balk 11:wand as 3'

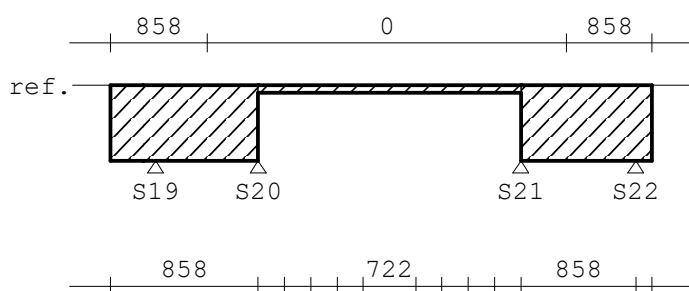

MEd dekkingslijn Fysisch lineair

Balk 11:wand as 3'

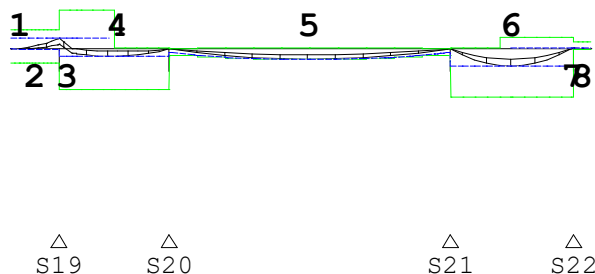

Hoofdwapening

Balk 11:wand as 3'

Geb.	Vanaf [mm]	Tot [mm]	M_{Ed} [kNm]	M_{Rd} [kNm]	z [mm]	B/O	A_b [mm ²]	A_a [mm ²]	Opm.
1	S19-550	S19-348	-1.76	-98.41	330	Ond	858*	858	2,54
2	S19-550	S19+0	72.29	131.21	440	Bov	858*	858	2,54
3	S19+0	S19+196	72.29	266.90	894	Bov	858*	858	2,54
4	S19+79	S20+0	-50.50	-279.40	936	Ond	858*	858	2,54
5	S20+0	S21+0	-69.30	-69.30	218	Ond	722	722	
6	S21+0	S22-29	-114.59	-327.18	1097	Ond	858*	858	2,54
7	S22-29	S22+0	9.75	81.79	274	Bov	858*	858	2,54
8	S22+0	S22+200	9.75	47.71	159	Bov	858*	858	2,54

Project.....: 21038 - Herman Gorterstraat

Hoofdwapening

Balk 11:wand as 3'

Geb.	Pos. [mm]	M_{Ed} [kNm]	M_{Rd} [kNm]	z B/O [mm]	A_b [mm ²]	A_a [mm ²]	Basiswapening +Bijlegwapening	Opm.
------	--------------	-------------------	-------------------	---------------	-----------------------------	-----------------------------	----------------------------------	------

Opmerkingen

[2] Benodigde wapening en inwendige hefboomsarm zijn bepaald volgens gedrongen ligger detaillering, zie nationale bijlage art. 6.1(10).

Alle maten zijn zonder verschuiving van de m-lijn en verankering

[54] * = Eisen met betrekking tot minimum wapening ten behoeve van gecontroleerde scheurvorming zijn toegepast volgens art. 7.3.2.

Scheurvorming volgens artikel 7.3.4

Balk 11:wand as 3'

Geb.	Pos. [mm]	Zijde	$M_{E;freq}$ [kNm]	$s_{r,max}$ [mm]	$\epsilon_{sm}-\epsilon_{cm}$ [%]	w_k [mm]	k_x	w_{max} [mm]	U.C.	Opm.
2	S19+0	Bov	53.55	228	0.067	0.015	2.00	0.800	0.02	
4	S19+597	Ond	-27.23	228	0.034	0.008	2.00	0.800	0.01	
5	S20+1600	Ond	-49.12	198	1.330	0.264	2.00	0.800	0.33	
6	S21+686	Ond	-84.17	228	0.105	0.024	2.00	0.800	0.03	
7	S22+0	Bov	7.16	228	0.009	0.002	2.00	0.800	0.00	

DWARSKRACHTEN

Fysisch lineair

Balk 11:wand as 3'

Fundamentele combinatie

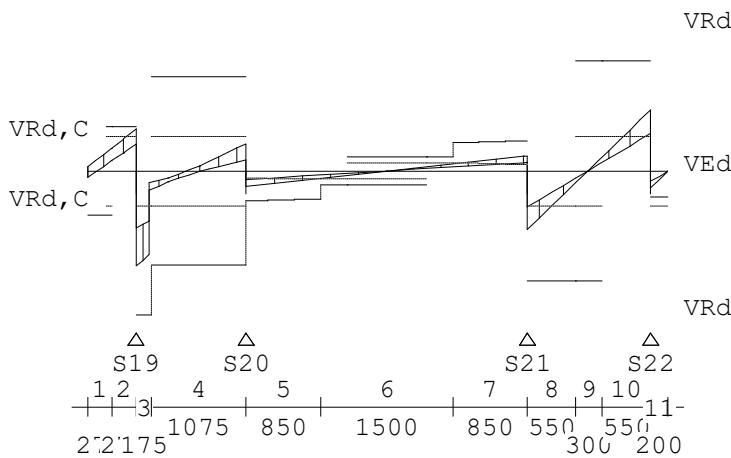

Wring- en dwarskrachtwapening

Balk 11:wand as 3'

Geb.	Vanaf [mm]	Tot [mm]	Beugels	Lengte [mm]	<Wringing >			<Dwarskr.>		Opm.
					A_{lang} [mm ²]	A_{bg1} [mm ² /m]	A_{opg} [mm ²]	V_{Ed} [kN]	T_{Ed} [kNm]	
1	S19-550	S19-275	Ø10-300	275	0	0	219	0	130.3	0 59
2	S19-275	S19+0	Ø10-300	275	0	0	498	0	238.1	0 6,59
3	S19+0	S19+175	Ø10-150	175	0	0	552	0	536.6	0 6,59
4	S19+175	S20+0	Ø10-300	1075	0	0	219	0	153.9	0 59
5	S20+0	S20+850	Ø8-150	850	0	0	342	0	86.5	0 6
6	S20+850	S21-850	Ø8-300	1500	0	0	219	0	40.5	0
7	S21-850	S21+0	Ø8-150	850	0	0	340	0	85.8	0 6
8	S21+0	S21+550	Ø10-300	550	0	0	279	0	332.8	0 6,59
9	S21+550	S22-550	Ø10-300	300	0	0	219	0	78.6	0 59
10	S22-550	S22+0	Ø10-300	550	0	0	291	0	346.7	0 6,59
11	S22+0	S22+200	Ø10-300	200	0	0	219	0	96.0	0 59

Project.....: 21038 - Herman Gorterstraat

Dwarskrachtwapening

Balk 11:wand as 3'

Geb.	Vanaf [mm]	Tot [mm]	Beugels	Lengte [mm]	A_{sw} [mm ² /m]	V_{Ed} [kN]	A_{opg} [mm ²]	Opm.
------	---------------	-------------	---------	----------------	----------------------------------	------------------	---------------------------------	------

Opmerkingen

[6] 9.2.2 (4) 50% van de dwarskrachtwapening moet uit beugels bestaan.

[59] 6.2.3: Z is berekend m.b.v. de gedrongen ligger berekening art 6.1 (10)

Wring- en dwarskrachten

Balk 11:wand as 3'

Geb.	Vanaf [mm]	Tot [mm]	θ [°]	V_{Rd} [kN]	V_{Ed}	$V_{Rd,C}$	$V_{Rd,Max}$	T_{Ed}	$T_{Rd,C}$	$T_{Rd,Max}$	V_{opg}	Opm.
					-----kN-----			-----kNm-----				
1	S19-550	S19-275	21.8	250	130	198	401	0	119	322	0	59
2	S19-275	S19+0	21.8	250	238	198	401	0	119	322	0	6,59
3	S19+0	S19+175	21.8	815	537	198	815	0	119	322	0	6,59
4	S19+175	S20+0	21.8	533	154	198	853	0	119	322	0	59
5	S20+0	S20+850	21.8	169	86	38	211	0	8	22	0	6
6	S20+850	S21-850	21.8	80	40	46	199	0	8	22	0	
7	S21-850	S21+0	21.8	169	86	38	211	0	8	22	0	6
8	S21+0	S21+550	21.8	624	333	198	999	0	119	322	0	6,59
9	S21+550	S22-550	21.8	624	79	198	999	0	119	322	0	59
10	S22-550	S22+0	21.8	624	347	198	999	0	119	322	0	6,59
11	S22+0	S22+200	21.8	91	96	198	146	0	119	322	0	59

Opmerkingen

[6] 9.2.2 (4) 50% van de dwarskrachtwapening moet uit beugels bestaan.

[59] 6.2.3: Z is berekend m.b.v. de gedrongen ligger berekening art 6.1 (10)

Hoofdwapening Fysisch lineair

Balk 12:wand as 3''

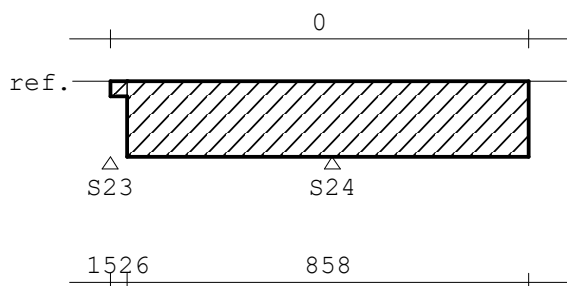

MEd dekkingslijn Fysisch lineair

Balk 12:wand as 3''

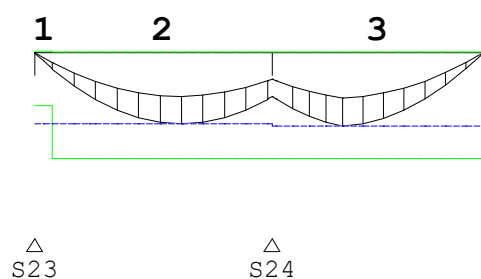

Project.....: 21038 - Herman Gorterstraat

Hoofdwapening

Balk 12:wand as 3''

Geb.	Vanaf [mm]	Tot [mm]	M _{Ed} [kNm]	M _{Rd} [kNm]	z B/O [mm]	A _b [mm ²]	A _a [mm ²]	Opm.
1	S23+0	S23+200	-358.65	-358.65	517	Ond	1528	1527
2	S23+200	S24+0	-484.93	-721.07	2417	Ond	858*	858 2,54
3	S24+0	S24+2400	-500.85	-721.07	2417	Ond	858*	858 2,54

Opmerkingen

[2] Benodigde wapening en inwendige hefboomsarm zijn bepaald volgens gedrongen ligger detaillering, zie nationale bijlage art. 6.1(10).

Alle maten zijn zonder verschuiving van de m-lijn en verankering

[54] * = Eisen met betrekking tot minimum wapening ten behoeve van gecontroleerde scheurvorming zijn toegepast volgens art. 7.3.2.

[93] **De wapening bij de doorsnede overgang is niet getoetst vlg. NEN-EN 1992-1-1 art.9.9.**

Scheurvorming volgens artikel 7.3.4

Balk 12:wand as 3''

Geb.	Pos. [mm]	Zijde	M _{E,freq} [kNm]	s _{r,max} [mm]	ε _{sm} -ε _{cm} [%]	w _k [mm]	k _x	w _{max} [mm]	U.C.	Opm.
1	S23+200	Ond	-80.34	323	0.310	0.100	1.17	0.350	0.29	
2	S24-1035	Ond	-356.19	228	0.491	0.112	2.00	0.800	0.14	
3	S24+800	Ond	-367.98	228	0.516	0.118	2.00	0.800	0.15	

DWARSKRACHTEN

Fysisch lineair Balk 12:wand as 3'' Fundamentele combinatie

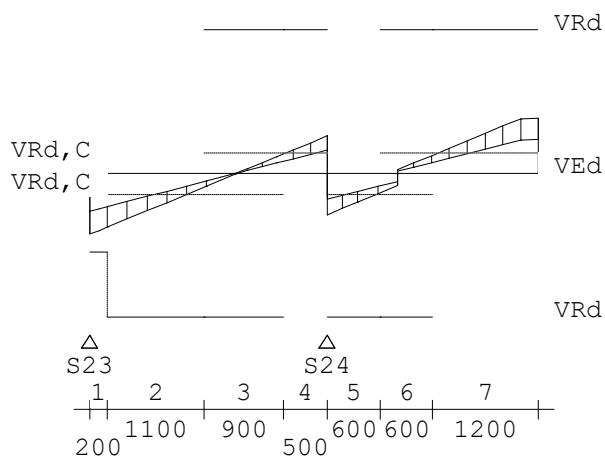

Wring- en dwarskrachtwapening

Balk 12:wand as 3''

Geb.	Vanaf [mm]	Tot [mm]	Beugels	Lengte [mm]	<Wringing >				V _{Ed} [kN]	T _{Ed} [kNm]	Opm.
					A _{lang} [mm ²]	A _{bg1} [mm ² /m]	A _{opg} [mm ²]				
1	S23+0	S23+200	2Ø8-150 (2s)	200	0	0	1030	0	579.3	0 6,8	
2	S23+200	S23+1300	Ø10-300	1100	0	0	219	0	511.8	0 6,59	
3	S23+1300	S24-500	Ø10-300	900	0	0	219	0	186.4	0 59	
4	S24-500	S24+0	Ø10-300	500	0	0	219	0	361.5	0 6,59	
5	S24+0	S24+600	Ø10-300	600	0	0	219	0	393.5	0 6,59	
6	S24+600	S24+1200	Ø10-300	600	0	0	219	0	183.4	0 59	
7	S24+1200	S24+2400	Ø10-300	1200	0	0	219	0	532.1	0 6,59	

Project.....: 21038 - Herman Gorterstraat

Dwarskrachtwapening

Balk 12:wand as 3''

Geb.	Vanaf [mm]	Tot [mm]	Beugels	Lengte [mm]	A_{sw} [mm ² /m]	V_{Ed} [kN]	A_{opg} [mm ²]	Opm.
------	---------------	-------------	---------	----------------	----------------------------------	------------------	---------------------------------	------

Opmerkingen

[6] 9.2.2 (4) 50% van de dwarskrachtwapening moet uit beugels bestaan.**[8] Er zijn meer dan 2 beugelsneden per doorsnede toegepast.**

[59] 6.2.3: Z is berekend m.b.v. de gedrongen ligger berekening art 6.1 (10)

Wring- en dwarskrachten

Balk 12:wand as 3''

Geb.	Vanaf [mm]	Tot [mm]	θ [°]	V_{Rd} [kN]	V_{Ed}	$V_{Rd,C}$	$V_{Rd,Max}$	T_{Ed}	$T_{Rd,C}$	$T_{Rd,Max}$	V_{opg}	Opm.
					-----kN-----			-----kNm-----				
1	S23+0	S23+200	21.8	754	579	152	1130	0	82	221	0	6,8
2	S23+200	S23+1300	21.8	1376	512	198	2201	0	119	322	0	6,59
3	S23+1300	S24-500	21.8	1376	186	198	2201	0	119	322	0	59
4	S24-500	S24+0	21.8	1376	361	198	2201	0	119	322	0	6,59
5	S24+0	S24+600	21.8	1376	394	198	2201	0	119	322	0	6,59
6	S24+600	S24+1200	21.8	1376	183	198	2201	0	119	322	0	59
7	S24+1200	S24+2400	21.8	1376	532	198	2201	0	119	322	0	6,59

Opmerkingen

[6] 9.2.2 (4) 50% van de dwarskrachtwapening moet uit beugels bestaan.**[8] Er zijn meer dan 2 beugelsneden per doorsnede toegepast.**

[59] 6.2.3: Z is berekend m.b.v. de gedrongen ligger berekening art 6.1 (10)

5.3

BIJLAGE 3 – WAND AS D, 1^E VERD. TS LIGGERS

BIJ

LA

GE



Technosoft Liggers release 6.76

17 mei 2023

Project.....: 21038 - Herman Gorterstraat

Onderdeel....: Wand as D

Constructeur.: 5.1, 2, e

Dimensies....: N m Pa

Datum.....: 15/09/2022

Bestand.....: J:\Dropbox (BREEDID)\Projecten 2021\21038 - Herman Gorterstraat\BREED ID\Calculations\5_Werkfase\wapening wanden + keldervloer\20230516_wand as D.dlw

Betrouwbaarheidsklasse : 2 Referentieperiode : 50
 Herverdelen van momenten : nee Maximale deellengte : 0.500
 Ouderdom bij belasten : 28 Relatieve vochtigheid : 50%
 Doorbuigingen(beton) zijn dmv gecorrigeerde stijfheden berekend.

Fysisch lineair : Er is gerekend met de e-modulus uit de materiaaltabel.
 Fys.NLE.kort : Er is gerekend met een gecorrigeerde e-modulus (korte duur).
 Deze e-mod. is berekend mbv de krachten uit de fysisch lineair berekening.

Toegepaste normen volgens Eurocode met Nederlandse NB

Belastingen	NEN-EN 1990:2002	C2:2010,A1:2019	NB:2019 (nl)
	NEN-EN 1991-1-1:2002	C1/C11:2019	NB:2019 (nl)
Beton	NEN-EN 1992-1-1:2011 (nl)	C2/A1:2015 (nl)	NB:2016 (nl)



Toevallige inklemmingen begin : 15% Toevallige inklemming eind : 15%
 Toevallige inklemmingen : 15% op tussensteunpunten met een scharnier.

GEOMETRIE

Ligger:1

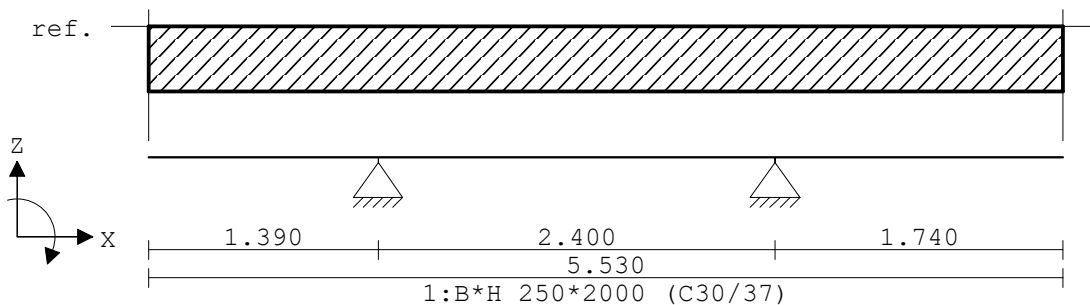

VELDLENGTEN

Ligger:1

Veld	Vanaf	Tot	Lengte
1	0.000	1.390	1.390
2	1.390	3.790	2.400
3	3.790	5.530	1.740

Project.....: 21038 - Herman Gorterstraat

Onderdeel....: Wand as D

MATERIALEN

Mt	Kwaliteit	E-modulus[N/mm2]	S.G.	Pois.	Uitz. coëff
1	C30/37	9465	25.0	0.20	1.0000e-05

MATERIALEN vervolg

Mt	Kwaliteit	Cement	Kruipfac.
1	C30/37	N	2.47

PROFIELEN [mm]

Prof.	Omschrijving	Materiaal	Oppervlak	Traagheid	Vormf.
1	B*H 250*2000	1:C30/37	5.0000e+05	1.6667e+11	0.00

PROFIELEN vervolg [mm]

Prof.	Staaftype	Breedte	Hoogte	e	Type	b1	h1	b2	h2
1	0:Normaal	250	2000	1000.0	0:RH				

PROFIELVORMEN [mm]

1 B*H 250*2000



BELASTINGGEVALLEN

B.G.	Omschrijving	Belast/onbelast	Ψ_0	Ψ_1	Ψ_2	e.g.
1	Permanent	2:Permanent EN1991				-1.00
2	Veranderlijk	1:Schaakbord EN1991	0.60	0.70	0.60	0.00

BELASTINGGEVALLEN

B.G.	Omschrijving	Type
1	Permanent	1 Permanente belasting
2	Veranderlijk	2 Ver. bel. pers. ed. (q_k)

VELDBELASTINGEN

Ligger:1 B.G:1 Permanent

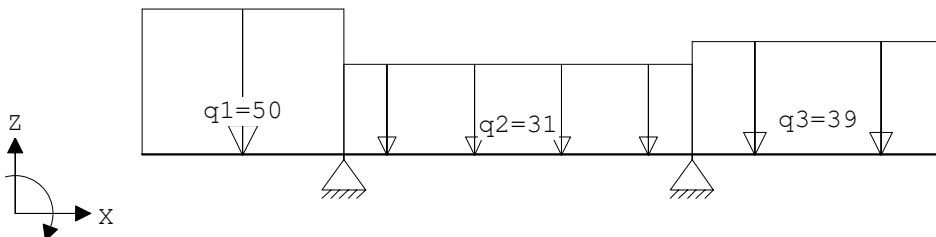

Project.....: 21038 - Herman Gorterstraat

Onderdeel....: Wand as D

VELDBELASTINGEN

Ligger:1 B.G:1 Permanent

Last Ref.	Type	Omschrijving	q1/p/m	q2	psi	Afstand	Lengte
1	1:q-last	q1	-50.000	-50.000		0.000	1.390
2	1:q-last	q2	-31.000	-31.000		1.390	2.400
3	1:q-last	q3	-39.000	-39.000		3.790	1.740

VELDBELASTINGEN

Ligger:1 B.G:2 Veranderlijk

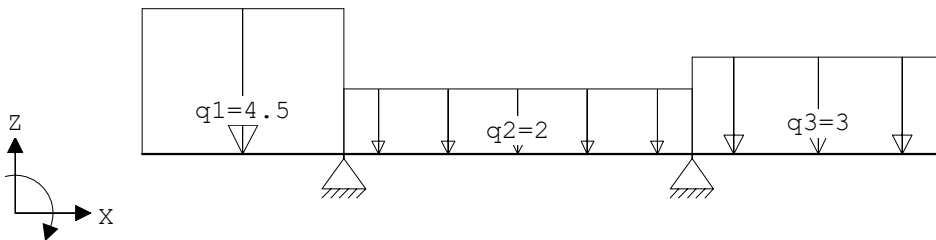

VELDBELASTINGEN

Ligger:1 B.G:2 Veranderlijk

Last Ref.	Type	Omschrijving	q1/p/m	q2	psi	Afstand	Lengte
1	1:q-last	q1	-4.500	-4.500		0.000	1.390
2	1:q-last	q2	-2.000	-2.000		1.390	2.400
3	1:q-last	q3	-3.000	-3.000		3.790	1.740

BELASTINGCOMBINATIES

BC Type	BG	Gen.	Factor	BG	Gen.	Factor	BG	Gen.	Factor	BG	Gen.	Factor
1	Fund.	1	Perm	1.35								
2	Fund.	1	Perm	1.35	2	psi0	1.50					
3	Fund.	1	Perm	1.20	2	Extr	1.50					
4	Fund.	1	Perm	0.90								
5	Fund.	1	Perm	0.90	2	psi0	1.50					
6	Fund.	1	Perm	0.90	2	Extr	1.50					
7	Kar.	1	Perm	1.00	2	Extr	1.00					
8	Freq.	1	Perm	1.00								
9	Freq.	1	Perm	1.00	2	psi1	1.00					
10	Quas.	1	Perm	1.00								
11	Quas.	1	Perm	1.00	2	psi2	1.00					
12	Blij.	1	Perm	1.00								

GUNSTIGE WERKING PERMANENTE BELASTINGEN

BC Velden met gunstige werking
1 Geen
2 Geen
3 Geen
4 Alle velden de factor:0.90
5 Alle velden de factor:0.90

Project.....: 21038 - Herman Gorterstraat

Onderdeel....: Wand as D

GUNSTIGE WERKING PERMANENTE BELASTINGEN

BC Velden met gunstige werking

6 Alle velden de factor:0.90

OMHULLENDE VAN DE FUNDAMENTELE COMBINATIES

MOMENTEN Fysisch lineair

Ligger:1 Fundamentele combinatie

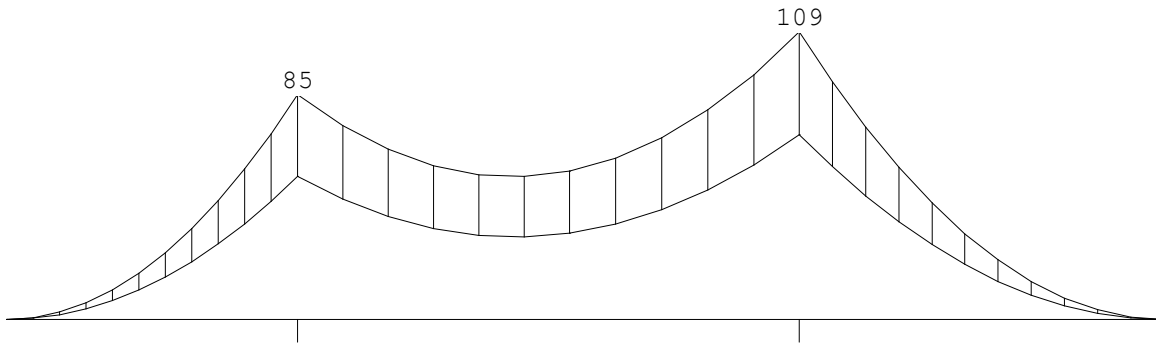

DWARSKRACHTEN Fysisch lineair

Ligger:1 Fundamentele combinatie

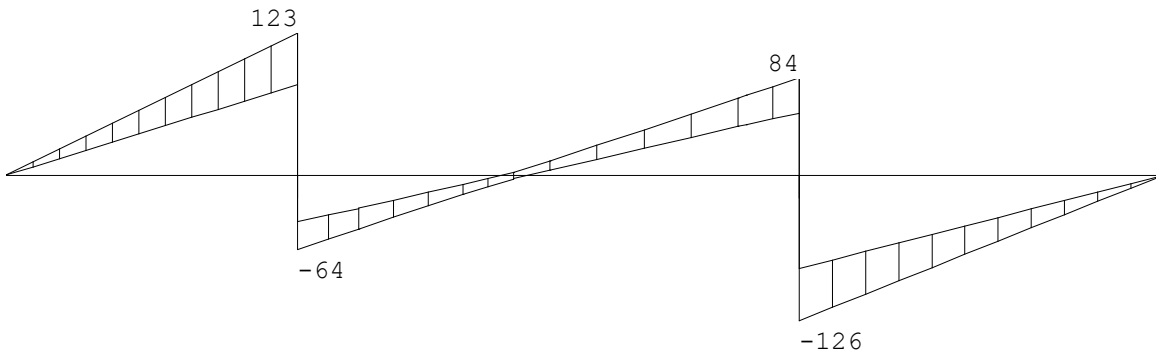

Fmin:119
Fmax:187

134
210

REACTIES Fysisch lineair

Ligger:1 Fundamentele combinatie

Stp	Fmin	Fmax	Mmin	Mmax
1	118.57	187.28	0.00	0.00
2	134.22	209.89	0.00	0.00

Project.....: 21038 - Herman Gorterstraat

Onderdeel....: Wand as D

Hoofdwapening Fysisch lineair

Ligger:1 Fundamentele combinatie

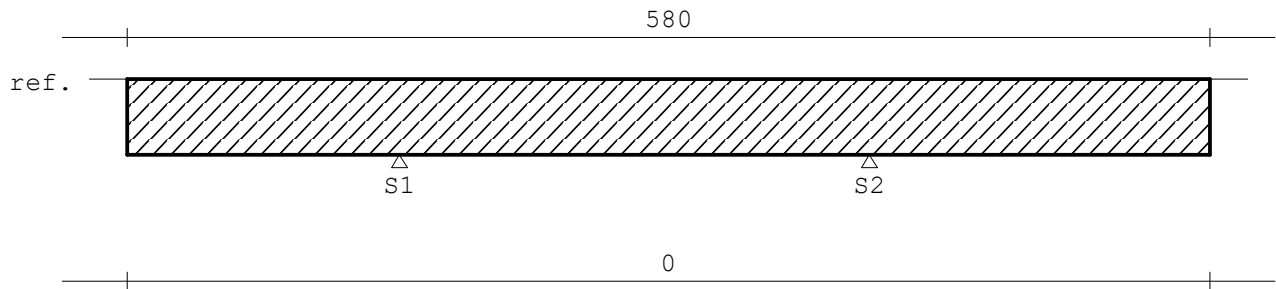

MEd dekkingslijn Fysisch lineair

Ligger:1 Fundamentele combinatie

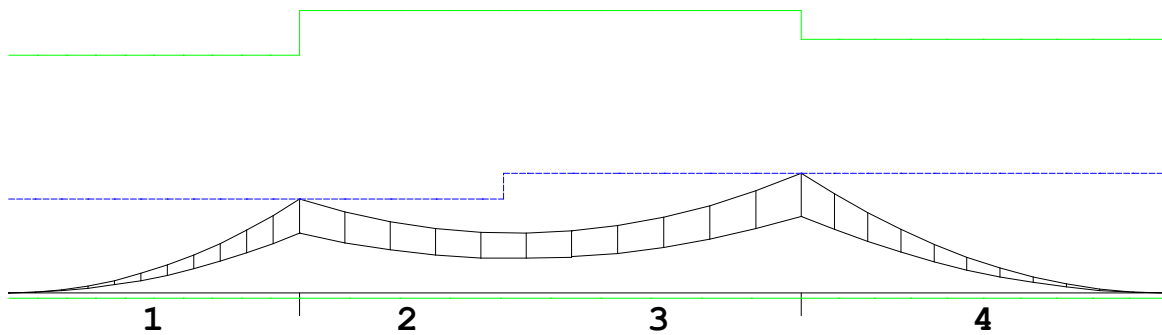

Hoofdwapening

Ligger:1

Geb.	Vanaf [mm]	Tot [mm]	M_{Ed} [kNm]	M_{Rd} [kNm]	z [mm]	B/O	A_b [mm ²]	A_a [mm ²]	Opm.
1	S1-1390	S1+0	85.42	217.21	1078	Bov	580*	580	2,54
2	S1+0	S1+1030	85.42	257.91	1280	Bov	580*	580	2,54
3	S1+1030	S2+0	109.33	257.91	1280	Bov	580*	580	2,54
4	S2+0	S2+1740	109.33	231.31	1148	Bov	580*	580	2,54

Opmerkingen

[2] Benodigde wapening en inwendige hefboomsarm zijn bepaald volgens gedrongen ligger detaillering, zie nationale bijlage art. 6.1(10).

Alle maten zijn zonder verschuiving van de m-lijn en verankering

[54] * = Eisen met betrekking tot minimum wapening ten behoeve van gecontroleerde scheurvorming zijn toegepast volgens art. 7.3.2.

Scheurvorming volgens artikel 7.3.4

Ligger:1

Geb.	Pos. [mm]	Zijde	$M_{E;freq}$ [kNm]	$s_{r,max}$ [mm]	$\epsilon_{sm} - \epsilon_{cm}$ [%]	w_k [mm]	k_x	w_{max} [mm]	U.C.	Opm.
1	S1+0	Bov	63.42	254	0.175	0.044	2.00	0.800	0.06	
3	S2+0	Bov	81.14	254	0.224	0.057	2.00	0.800	0.07	

Project.....: 21038 - Herman Gorterstraat

Onderdeel....: Wand as D

Dwarskrachtwapening

Ligger:1

Geb.	Vanaf [mm]	Tot [mm]	Beugels	Lengte [mm]	A_{sw} [mm ² /m]	V_{Ed} [kN]	A_{opg} [mm ²]	Opm.
1	S1-1390	S1+0	Ø8-300	1390	219	123		59
2	S1+0	S2+0	Ø8-300	2400	219	84		59
3	S2+0	S2+1740	Ø8-300	1740	219	125		59

Opmerkingen

[59] 6.2.3: Z is berekend m.b.v. de gedrongen ligger berekening art 6.1 (10)

Schuifspanningen

Ligger:1

Geb.	Vanaf [mm]	Tot [mm]	θ [°]	V_{Ed} [kN]	$v_{Rd,C}$	$v_{Rd,S}$	$v_{Ed} < v_{Rd} < v_{Rd,Max}$ [N/mm ²]			Opm.
1	S1-1390	S1+0	21.8	122.65	0.29	0.81	0.25	0.81	2.01	59
2	S1+0	S2+0	21.8	84.04	0.29	0.96	0.17	0.96	2.39	59
3	S2+0	S2+1740	21.8	125.45	0.29	0.86	0.26	0.86	2.14	59

Opmerkingen

[59] 6.2.3: Z is berekend m.b.v. de gedrongen ligger berekening art 6.1 (10)

5.4

BIJLAGE 4 – WAND AS A, 1^E VERD., TUSSEN AS 1-5

BIJ

LA

GE



Technosoft Liggers release 6.76 17 mei 2023
 Project.....: 21038 - Herman Gorterstraat
 Onderdeel....: Wand as A
 Constructeur. **5.1, 2, e**
 Dimensies....: kN/m/rad
 Datum.....: 07/09/2022
 Bestand.....: J:\Dropbox (BREEDID)\Projecten 2021\21038 - Herman
 Gorterstraat\BREED ID\Calculations\5_Werkfase\Wanden gew
 berek\wand as A (2).dlw

Betrouwbaarheidsklasse : 2 Referentieperiode : 50
 Herverdelen van momenten : nee Maximale deellengte : 0.500
 Ouderdom bij belasten : 28 Relatieve vochtigheid : 50%
 Doorbuigingen(beton) zijn dmv gecorrigeerde stijfheden berekend.

Fysisch lineair : Er is gerekend met de e-modulus uit de materiaaltabel.
 Fys.NLE.kort : Er is gerekend met een gecorrigeerde e-modulus (korte duur).
 Deze e-mod. is berekend mbv de krachten uit de fysisch lineair berekening.

Toegepaste normen volgens Eurocode met Nederlandse NB

Belastingen	NEN-EN 1990:2002	C2:2010,A1:2019	NB:2019(nl)
	NEN-EN 1991-1-1:2002	C1/C11:2019	NB:2019(nl)
Beton	NEN-EN 1992-1-1:2011(nl)	C2/A1:2015(nl)	NB:2016(nl)



LIGGER: 2

Toevallige inklemmingen begin : 15% Toevallige inklemming eind : 15%
 Toevallige inklemmingen : 15% op tussensteunpunten met een scharnier.

GEOMETRIE

Ligger:2

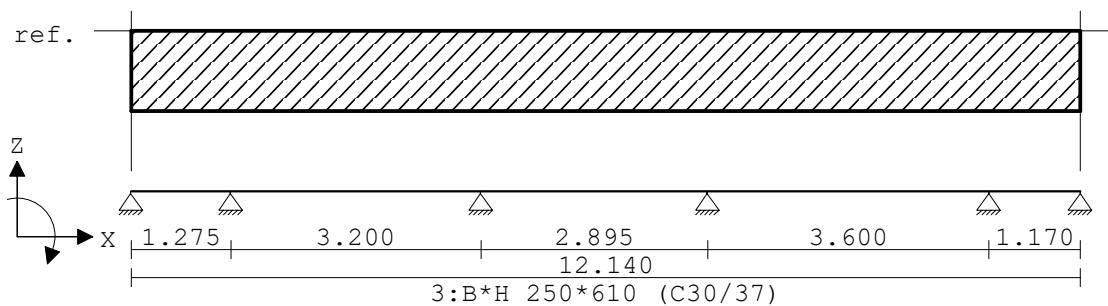

VELDLENGTEN

Ligger:2

Veld	Vanaf	Tot	Lengte
1	0.000	1.275	1.275
2	1.275	4.475	3.200
3	4.475	7.370	2.895
4	7.370	10.970	3.600
5	10.970	12.140	1.170

Project.....: 21038 - Herman Gorterstraat

Onderdeel....: Wand as A

MATERIALEN

Mt	Kwaliteit	E-modulus[N/mm2]	S.G.	Pois.	Uitz. coëff
1	C30/37	9465	25.0	0.20	1.0000e-05

MATERIALEN vervolg

Mt	Kwaliteit	Cement	Kruipfac.
1	C30/37	N	2.47

PROFIELEN [mm]

Prof.	Omschrijving	Materiaal	Oppervlak	Traagheid	Vormf.
1	B*H 250*610	1:C30/37	1.5250e+05	4.7288e+09	0.00
2	B*H 250*1600	1:C30/37	4.0000e+05	8.5333e+10	0.00
3	B*H 250*610	1:C30/37	1.5250e+05	4.7288e+09	0.00

PROFIELEN vervolg [mm]

Prof.	Staaftype	Breedte	Hoogte	e	Type	b1	h1	b2	h2
1	0:Normaal	250	610	305.0	0:RH				
2	0:Normaal	250	1600	800.0	0:RH				
3	0:Normaal	250	610	305.0	0:RH				



DOORSNEDEN

Ligger:2

sector	Vanaf	Tot	Lengte	Profiel begin	z-begin	Profiel eind	z-eind
1	0.000	12.140	12.140	3:B*H 250*610	0.000	3:B*H 250*610	0.000

sector	Vanaf	Tot	Lengte	Eindcode	Bedding	Br.[mm]
1	0.000	12.140	12.140	1:Vast		

PROFIELVORMEN [mm]

1	B*H 250*610	
2	B*H 250*1600	
3	B*H 250*610	

Project.....: 21038 - Herman Gorterstraat

Onderdeel....: Wand as A

BELASTINGGEVALLEN

B.G.	Omschrijving	Belast/onbelast	Ψ_0	Ψ_1	Ψ_2	e.g.
1	Permanent	2:Permanent EN1991				0.00
2	Veranderlijk	1:Schaakbord EN1991	0.40	0.50	0.30	0.00

BELASTINGGEVALLEN

B.G.	Omschrijving	Type
1	Permanent	1 Permanente belasting
2	Veranderlijk	2 Ver. bel. pers. ed. (q_k)

VELDBELASTINGEN

Ligger:2 B.G:1 Permanent

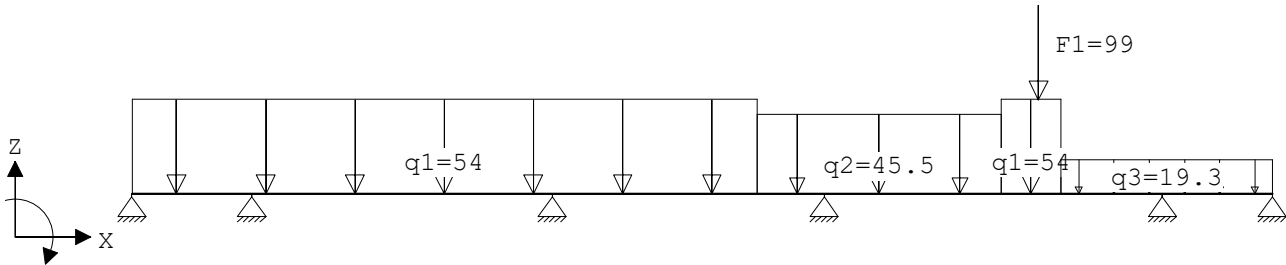

VELDBELASTINGEN

Ligger:2 B.G:1 Permanent

Last Ref.	Type	Omschrijving	q1/p/m	q2	psi	Afstand	Lengte
1	1:q-last	q1	-54.000	-54.000		0.000	6.650
2	1:q-last	q2	-45.500	-45.500		6.650	2.600
3	1:q-last	q1	-54.000	-54.000		9.250	0.640
4	1:q-last	q3	-19.300	-19.300		9.890	2.250
5	8:Puntlast	F1	-99.000			9.650	

VELDBELASTINGEN

Ligger:2 B.G:2 Veranderlijk

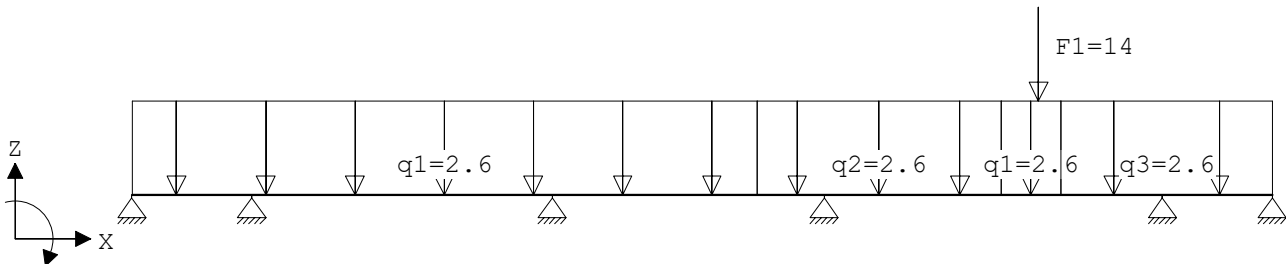

Project.....: 21038 - Herman Gorterstraat

Onderdeel....: Wand as A

VELDBELASTINGEN

Ligger:2 B.G:2 Veranderlijk

Last Ref.	Type	Omschrijving	q1/p/m	q2	psi	Afstand	Lengte
1	1:q-last	q1	-2.600	-2.600		0.000	6.650
2	1:q-last	q2	-2.600	-2.600		6.650	2.600
3	1:q-last	q1	-2.600	-2.600		9.250	0.640
4	1:q-last	q3	-2.600	-2.600		9.890	2.250
5	8:Puntlast	F1	-14.000			9.650	

BELASTINGCOMBINATIES

BC Type	BG	Gen.	Factor	BG	Gen.	Factor	BG	Gen.	Factor	BG	Gen.	Factor
1 Fund.	1	Perm	1.35									
2 Fund.	1	Perm	1.35	2	psi0	1.50						
3 Fund.	1	Perm	1.20	2	Extr	1.50						
4 Fund.	1	Perm	0.90									
5 Fund.	1	Perm	0.90	2	psi0	1.50						
6 Fund.	1	Perm	0.90	2	Extr	1.50						
7 Kar.	1	Perm	1.00	2	Extr	1.00						
8 Freq.	1	Perm	1.00									
9 Freq.	1	Perm	1.00	2	psi1	1.00						
10 Quas.	1	Perm	1.00									
11 Quas.	1	Perm	1.00	2	psi2	1.00						
12 Blij.	1	Perm	1.00									

GUNSTIGE WERKING PERMANENTE BELASTINGEN

BC Velden met gunstige werking
1 Geen
2 Geen
3 Geen
4 Alle velden de factor:0.90
5 Alle velden de factor:0.90
6 Alle velden de factor:0.90

Project.....: 21038 - Herman Gorterstraat

Onderdeel....: Wand as A

OMHULLENDE VAN DE FUNDAMENTELE COMBINATIES

MOMENTEN Fysisch lineair

Ligger:2 Fundamentele combinatie

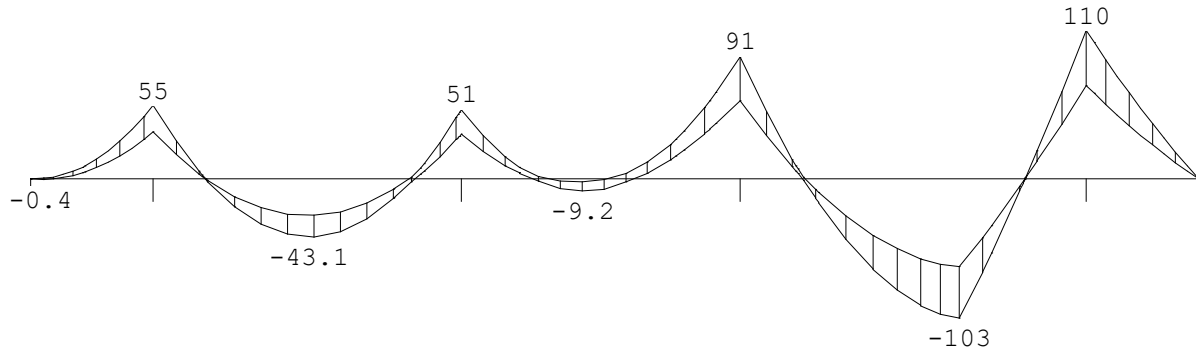

DWARSKRACHTEN Fysisch lineair

Ligger:2 Fundamentele combinatie

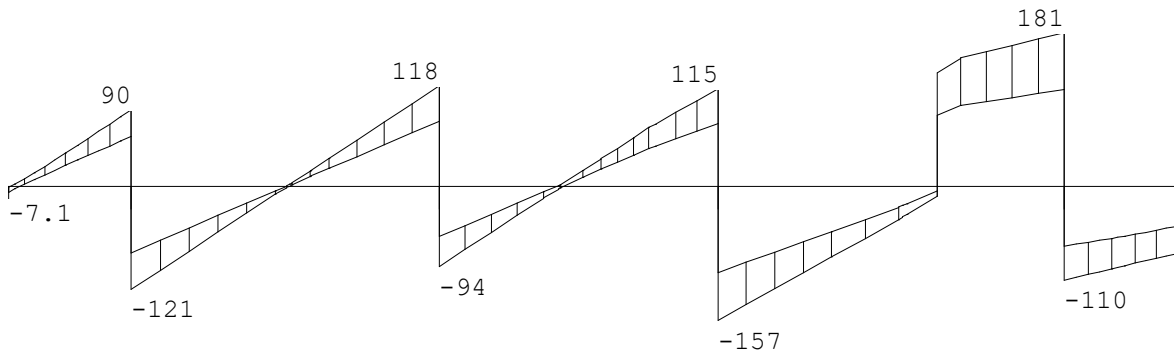

Fmin:0.46	137	138	175	184	-79
Fmax:7.1	211	213	272	291	-46.8

REACTIES Fysisch lineair

Ligger:2 Fundamentele combinatie

Stp	Fmin	Fmax	Mmin	Mmax
1	0.46	7.06	0.00	0.00
2	137.18	210.89	0.00	0.00
3	138.14	212.52	0.00	0.00
4	175.40	272.03	0.00	0.00
5	184.48	291.08	0.00	0.00
6	-78.68	-46.81	0.00	0.00

Project.....: 21038 - Herman Gorterstraat

Onderdeel....: Wand as A

Hoofdwapening Fysisch lineair

Ligger:2 Fundamentele combinatie

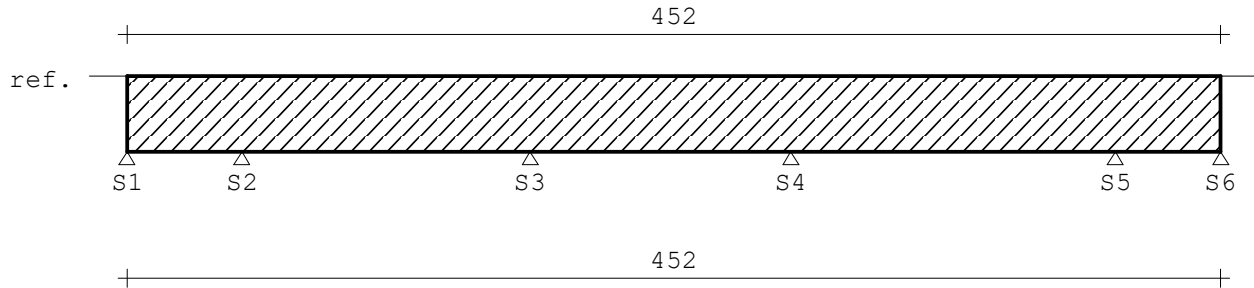

MEd dekkingslijn Fysisch lineair

Ligger:2 Fundamentele combinatie

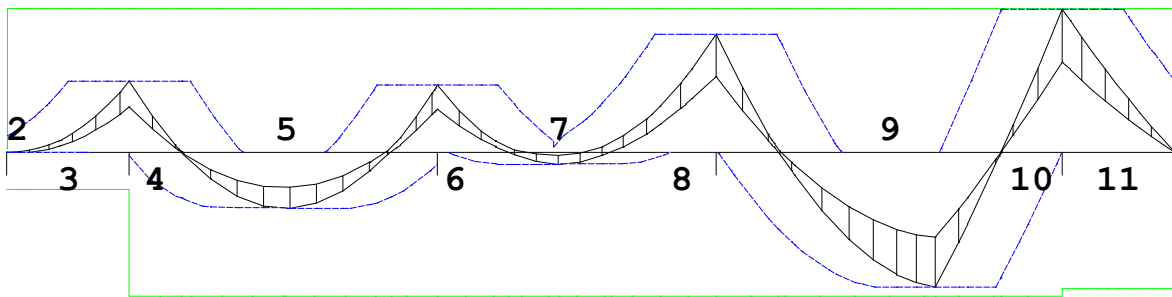

Hoofdwapening

Ligger:2

Geb.	Vanaf [mm]	Tot [mm]	M_{Ed} [kNm]	M_{Rd} [kNm]	z [mm]	B/O	A_b [mm ²]	A_a [mm ²]	Opm.
1	S1+0	S1+8	0.05	3.03	19	Bov	177*	452	2,54
1	S1+0	S1+8	0.05	3.03	19	Ond	0	452	
2	S1+0	S1+228	-0.36	-28.71	182	Bov	0	452	
2	S1+0	S1+228	-0.36	-28.71	182	Ond	177*	452	2,54
3	S1+19	S2+0	54.61	110.51	538	Bov	217	452	2,68
3	S1+19	S2+0	54.61	110.51	538	Ond	0	452	
4	S2+0	S2+548	54.61	110.51	538	Bov	217	452	
4	S2+0	S2+548	54.61	110.51	538	Ond	0	452	
5	S2+537	S3-479	-43.08	-110.51	538	Bov	0	452	
5	S2+537	S3-479	-43.08	-110.51	538	Ond	177*	452	54
6	S3-541	S3+909	51.39	110.51	538	Bov	203	452	
6	S3-541	S3+909	51.39	110.51	538	Ond	0	452	
7	S3+738	S4-1091	-9.16	-110.51	538	Bov	0	452	
7	S3+738	S4-1091	-9.16	-110.51	538	Ond	177*	452	54
8	S4-1381	S4+680	90.75	110.51	538	Bov	369	452	
8	S4-1381	S4+680	90.75	110.51	538	Ond	0	452	
9	S4+650	S5-635	-103.50	-110.51	538	Bov	0	452	
9	S4+650	S5-635	-103.50	-110.51	538	Ond	423	452	

Project.....: 21038 - Herman Gorterstraat

Onderdeel....: Wand as A

Hoofdwapening

Ligger:2

Geb.	Vanaf [mm]	Tot [mm]	M_{Ed} [kNm]	M_{Rd} [kNm]	z B/O [mm]	A_b [mm ²]	A_a [mm ²]	Opm.
10	S5-638	S5+0	109.97	110.51	538	Bov	450	452
10	S5-638	S5+0	109.97	110.51	538	Ond	0	452
11	S5+0	S6+0	109.97	110.51	538	Bov	450	452 2,68
11	S5+0	S6+0	109.97	110.51	538	Ond	0	452

Opmerkingen

[2] Benodigde wapening en inwendige hefboomsarm zijn bepaald volgens gedrongen ligger detaillering, zie nationale bijlage art. 6.1(10).

Alle maten zijn zonder verschuiving van de m-lijn en verankering

[54] * = Eisen met betrekking tot minimum wapening ten behoeve van gecontroleerde scheurvorming zijn toegepast volgens art. 7.3.2.

[68] MRd als gevolg van de gedrongen ligger berekening (NB. 6.1(10)) is groter dan MRd volgens 6.1(P). De momentweerstand en inwendige hefboomsarm volgens 6.1(P) zijn maatgevend en daarom alsnog toegepast.

Scheurvorming volgens artikel 7.3.4

Ligger:2

Geb.	Pos. [mm]	Zijde	$M_{E;freq}$ [kNm]	$s_{r,max}$ [mm]	$\epsilon_{sm} - \epsilon_{cm}$ [%]	w_k [mm]	k_x	w_{max} [mm]	U.C.	Opm.
2	S1+103	Ond	-0.18	284	0.002	0.001	2.00	0.800	0.00	
3	S2+0	Bov	40.59	284	0.511	0.145	2.00	0.800	0.18	
5	S3-1581	Ond	-32.03	284	0.403	0.115	2.00	0.800	0.14	
6	S3+0	Bov	38.21	284	0.481	0.137	2.00	0.800	0.17	
7	S3+1267	Ond	-6.43	284	0.081	0.023	2.00	0.800	0.03	
8	S4+0	Bov	67.54	284	0.989	0.281	2.00	0.800	0.35	
9	S5-1320	Ond	-77.14	284	1.190	0.339	2.00	0.800	0.42	
10	S5+0	Bov	81.95	284	1.291	0.367	2.00	0.800	0.46	

Dwarskrachtwapening

Ligger:2

Geb.	Vanaf [mm]	Tot [mm]	Beugels	Lengte [mm]	A_{sw} [mm ² /m]	V_{Ed} [kN]	A_{opg} [mm ²]	Opm.
1	S1+0	S2-487	Ø8-300	788	219	54	58	
2	S2-487	S2+0	Ø8-300	488	219	90	6,58	
3	S2+0	S2+850	Ø8-300	850	219	120	6	
4	S2+850	S3-850	Ø8-300	1500	219	57		
5	S3-850	S3+0	Ø8-300	850	219	118	6	
6	S3+0	S3+548	Ø8-300	548	219	94	6	
7	S3+548	S4-1148	Ø8-300	1200	219	53		
8	S4-1148	S4+0	Ø8-300	1148	219	114	6	
9	S4+0	S4+1800	Ø8-300	1800	269	157	6	
10	S4+1800	S5-1500	Ø8-300	300	219	44		
11	S5-1500	S5+0	Ø8-300	1500	309	181	6	

Project.....: 21038 - Herman Gorterstraat

Onderdeel....: Wand as A

Dwarskrachtwapening

Ligger:2

Geb.	Vanaf [mm]	Tot [mm]	Beugels	Lengte [mm]	A_{sw} [mm ² /m]	V_{Ed} [kN]	A_{opg} [mm ²]	Opm.
12	S5+0	S6+0	Ø8-300	1170	219	110		6,58

Opmerkingen

[6] 9.2.2 (4) 50% van de dwarskrachtwapening moet uit beugels bestaan.

[58] 6.2.3: Z is berekend m.b.v. 0.9d

Schuifspanningen

Ligger:2

Geb.	Vanaf [mm]	Tot [mm]	θ [°]	V_{Ed} [kN]	$V_{Rd,c}$	$V_{Rd,s}$	$V_{Ed} < V_{Rd} < V_{Rd,Max}$ [N/mm ²]	Opm.		
1	S1+0	S2-487	21.8	53.78	0.41	1.31	0.38	1.31	3.28	58
2	S2-487	S2+0	21.8	90.08	0.41	1.31	0.64	1.31	3.28	6,58
3	S2+0	S2+850	21.8	120.37	0.41	1.40	0.86	1.40	3.49	6
4	S2+850	S3-850	21.8	57.08	0.41	1.40	0.41	1.40	3.49	
5	S3-850	S3+0	21.8	118.10	0.41	1.40	0.84	1.40	3.49	6
6	S3+0	S3+548	21.8	93.98	0.41	1.40	0.67	1.40	3.49	6
7	S3+548	S4-1148	21.8	53.21	0.41	1.40	0.38	1.40	3.49	
8	S4-1148	S4+0	21.8	114.49	0.41	1.40	0.82	1.40	3.49	6
9	S4+0	S4+1800	21.8	157.17	0.41	1.40	1.12	1.40	3.49	6
10	S4+1800	S5-1500	21.8	43.79	0.41	1.40	0.31	1.40	3.49	
11	S5-1500	S5+0	21.8	180.85	0.41	1.40	1.29	1.40	3.49	6
12	S5+0	S6+0	21.8	110.06	0.41	1.31	0.78	1.31	3.28	6,58

Opmerkingen

[6] 9.2.2 (4) 50% van de dwarskrachtwapening moet uit beugels bestaan.

[58] 6.2.3: Z is berekend m.b.v. 0.9d

5.5

BIJLAGE 5 – WAND AS 4', 1^E VERD., TUSSEN AS C-D

BIJ

LA

GE



Technosoft Liggers release 6.76

17 mei 2023

Project.....: 21038 - Herman Gorterstraat

Onderdeel....: wand as 4'

Constructeur.: ing. 5.1, 2, e

Dimensies....: kN/m/rad

Datum.....: 28/09/2022

Bestand.....: J:\Dropbox (BREEDID)\Projecten 2021\21038 - Herman
Gorterstraat\BREED ID\Calculations\5_Werkfase\wapening
wanden + keldervloer\20230517_Wand as 4'.dlw

Betrouwbaarheidsklasse : 2 Referentieperiode : 50
Herverdelen van momenten : nee Maximale deellengte : 0.500
Ouderdom bij belasten : 28 Relatieve vochtigheid : 50%

Doorbuigingen(beton) zijn dmv gecorrigeerde stijfheden berekend.

Fysisch lineair : Er is gerekend met de e-modulus uit de materiaaltabel.
Fys.NLE.kort : Er is gerekend met een gecorrigeerde e-modulus (korte duur).
Deze e-mod. is berekend mbv de krachten uit de fysisch lineair berekening.

Toegepaste normen volgens Eurocode met Nederlandse NB

Belastingen	NEN-EN 1990:2002	C2:2010,A1:2019	NB:2019 (nl)
	NEN-EN 1991-1-1:2002	C1/C11:2019	NB:2019 (nl)
Beton	NEN-EN 1992-1-1:2011 (nl)	C2/A1:2015 (nl)	NB:2016 (nl)



Toevallige inklemmingen begin : 15% Toevallige inklemming eind : 15%
Toevallige inklemmingen : 15% op tussensteunpunten met een scharnier.

GEOMETRIE

Ligger:1

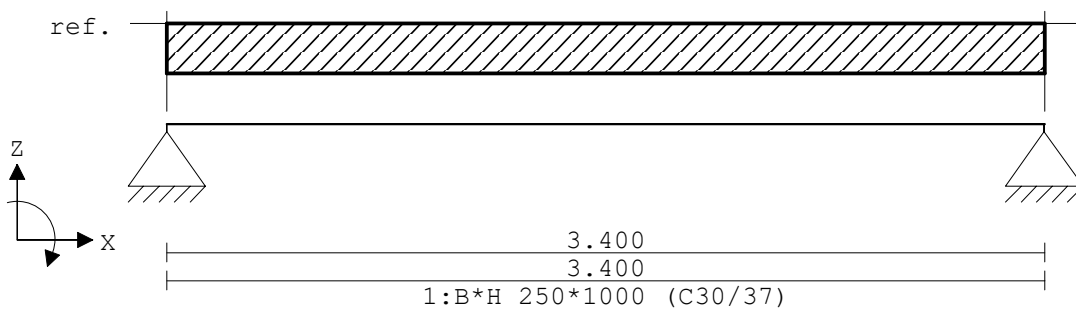

VELDLONGTEN

Ligger:1

Veld	Vanaf	Tot	Lengte
1	0.000	3.400	3.400

MATERIALEN

Mt	Kwaliteit	E-modulus [N/mm ²]	S.G.	Pois.	Uitz. coëff
1	C30/37	9465	25.0	0.20	1.0000e-05

Project.....: 21038 - Herman Gorterstraat
 Onderdeel....: wand as 4'

MATERIALEN vervolg

Mt	Kwaliteit	Cement	Kruipfac.
1	C30/37	N	2.47

PROFIELEN [mm]

Prof.	Omschrijving	Materiaal	Oppervlak	Traagheid	Vormf.
1	B*H 250*1000	1:C30/37	2.5000e+05	2.0833e+10	0.00

PROFIELEN vervolg [mm]

Prof.	Staaftype	Breedte	Hoogte	e	Type	b1	h1	b2	h2
1	0:Normaal	250	1000	500.0	0:RH				

PROFIELVORMEN [mm]

1 B*H 250*1000



BELASTINGGEVALLEN

B.G.	Omschrijving	Belast/onbelast	Ψ_0	Ψ_1	Ψ_2	e.g.
1	Permanente belasting	2:Permanent EN1991				0.00
2	Variabele belasting	1:Schaakbord EN1991	0.40	0.50	0.30	0.00

BELASTINGGEVALLEN

B.G.	Omschrijving	Type
1	Permanente belasting	1
2	Variabele belasting	2 Ver. bel. pers. ed. (q_k)

VELDBELASTINGEN

Ligger:1 B.G:1 Permanente belasting

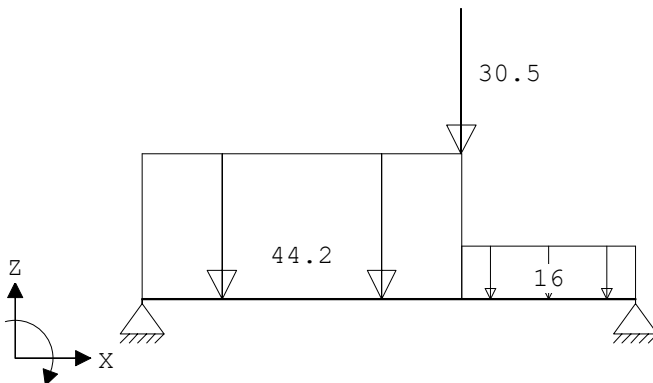

Project.....: 21038 - Herman Gorterstraat
 Onderdeel....: wand as 4'

VELDBELASTINGEN

Ligger:1 B.G:1 Permanente belasting

Last Ref.	Type	Omschrijving	q1/p/m	q2	psi	Afstand	Lengte
1	1:q-last		-44.200	-44.200		0.000	2.200
2	1:q-last		-16.000	-16.000		2.200	1.200
3	8:Puntlast		-30.500			2.200	

VELDBELASTINGEN

Ligger:1 B.G:2 Variabele belasting



VELDBELASTINGEN

Ligger:1 B.G:2 Variabele belasting

Last Ref.	Type	Omschrijving	q1/p/m	q2	psi	Afstand	Lengte
1	8:Puntlast		-2.600			2.200	

BELASTINGCOMBINATIES

BC Type	BG	Gen.	Factor	BG	Gen.	Factor	BG	Gen.	Factor	BG	Gen.	Factor
1 Fund.	1	Perm	1.20									
2 Fund.	1	Perm	1.35									
3 Fund.	1	Perm	1.35	2	psi0	1.50						
4 Fund.	1	Perm	1.20	2	Extr	1.50						
5 Fund.	1	Perm	0.90									
6 Fund.	1	Perm	0.90	2	psi0	1.50						
7 Fund.	1	Perm	0.90	2	Extr	1.50						
8 Kar.	1	Perm	1.00	2	Extr	1.00						
9 Freq.	1	Perm	1.00									
10 Freq.	1	Perm	1.00	2	psi1	1.00						
11 Quas.	1	Perm	1.00									
12 Quas.	1	Perm	1.00	2	psi2	1.00						
13 Blij.	1	Perm	1.00									

GUNSTIGE WERKING PERMANENTE BELASTINGEN

BC Velden met gunstige werking

- 1 Geen
- 2 Geen
- 3 Geen
- 4 Geen
- 5 Alle velden de factor:0.90
- 6 Alle velden de factor:0.90

Project.....: 21038 - Herman Gorterstraat

Onderdeel....: wand as 4'

GUNSTIGE WERKING PERMANENTE BELASTINGEN

BC Velden met gunstige werking

7 Alle velden de factor:0.90

OMHULLENDE VAN DE FUNDAMENTELE COMBINATIES

MOMENTEN Fysisch lineair

Ligger:1 Fundamentele combinatie

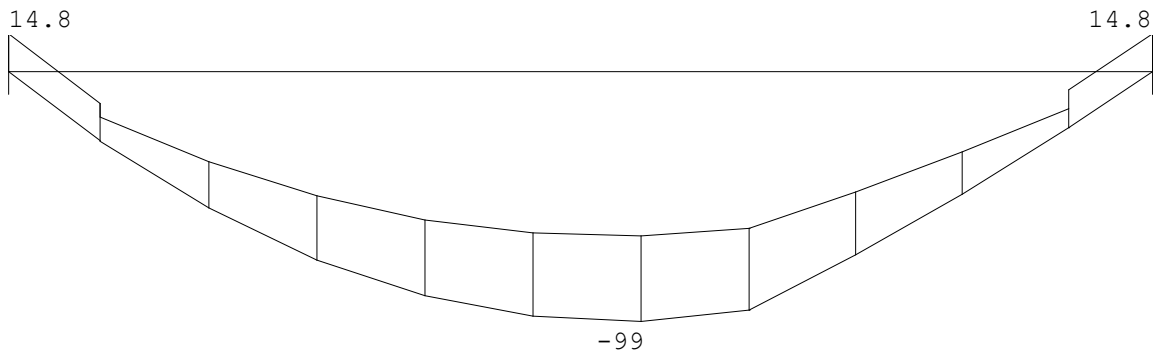

DWARSKRACHTEN Fysisch lineair

Ligger:1 Fundamentele combinatie

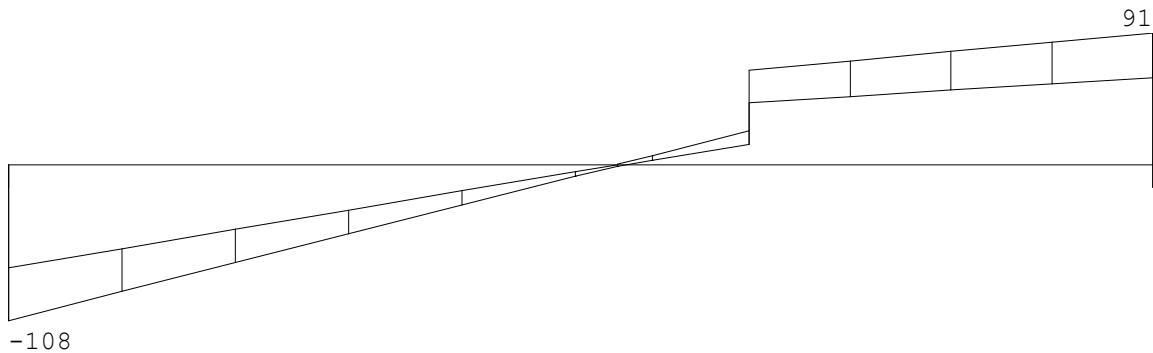

Fmin:72
Fmax:108

60
91

REACTIES Fysisch lineair

Ligger:1 Fundamentele combinatie

Stp	Fmin	Fmax	Mmin	Mmax
1	71.94	108.46	0.00	0.00
2	60.31	91.47	0.00	0.00

Project.....: 21038 - Herman Gorterstraat
 Onderdeel....: wand as 4'

Hoofdwapening Fysisch lineair

Ligger:1 Fundamentele combinatie

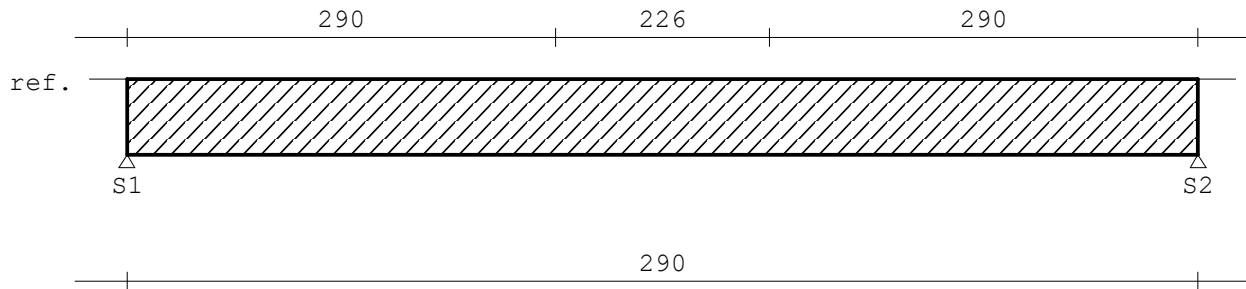

MEd dekkingslijn Fysisch lineair

Ligger:1 Fundamentele combinatie

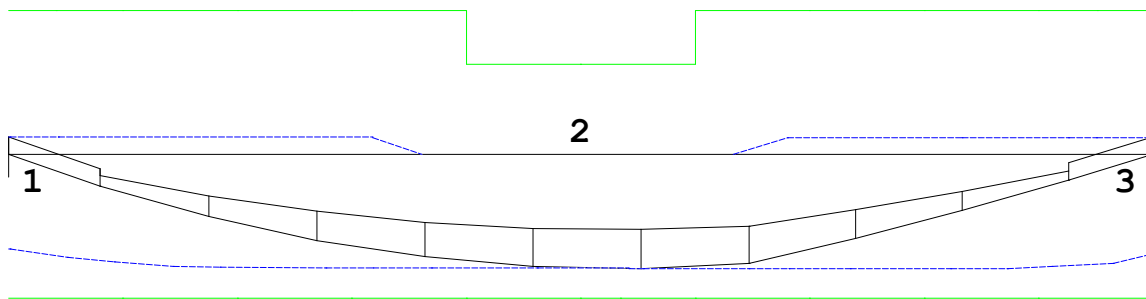

Hoofdwapening

Ligger:1

Geb.	Vanaf [mm]	Tot [mm]	M_{Ed} [kNm]	M_{Rd} [kNm]	z [mm]	B/O	A_b [mm ²]	A_a [mm ²]	Opm.
1	S1+0	S1+142	14.79	123.86	941	Bov	290*	290	54
1	S1+0	S1+142	14.79	123.86	941	Ond	0	290	
2	S1+0	S2+0	-98.57	-123.86	941	Bov	0	226	
2	S1+0	S2+0	-98.57	-123.86	941	Ond	290*	290	54
3	S2-165	S2+0	14.79	123.86	941	Bov	290*	290	54
3	S2-165	S2+0	14.79	123.86	941	Ond	0	290	

Opmerkingen

Alle maten zijn zonder verschuiving van de m-lijn en verankering

[54] * = Eisen met betrekking tot minimum wapening ten behoeve van gecontroleerde scheurvorming zijn toegepast volgens art. 7.3.2.

Scheurvorming volgens artikel 7.3.4

Ligger:1

Geb.	Pos. [mm]	Zijde	$M_E; freq$ [kNm]	$s_{r,max}$ [mm]	$\epsilon_{sm} - \epsilon_{cm}$ [%]	w_k [mm]	k_x	w_{max} [mm]	U.C.	Opm.
2	S2-1582	Ond	-73.11	283	0.841	0.239	1.67	0.667	0.36	

Project.....: 21038 - Herman Gorterstraat

Onderdeel....: wand as 4'

Dwarskrachtwapening

Ligger:1

Geb.	Vanaf [mm]	Tot [mm]	Beugels	Lengte [mm]	A_{sw} [mm ² /m]	V_{Ed} [kN]	A_{opg} [mm ²]	Opm.
1	S1+0	S1+500	Ø8-300	500	219	108		6
2	S1+500	S2-500	Ø8-300	2400	219	81		
3	S2-500	S2+0	Ø8-300	500	219	91		6

Opmerkingen

[6] 9.2.2 (4) 50% van de dwarskrachtwapening moet uit beugels bestaan.**Schuifspanningen**

Ligger:1

Geb.	Vanaf [mm]	Tot [mm]	θ [°]	V_{Ed} [kN]	$v_{Rd,C}$	$v_{Rd,S}$	$v_{Ed} < v_{Rd} < v_{Rd,Max}$ [N/mm ²]		Opm.	
1	S1+0	S1+500	21.8	108.28	0.34	1.43	0.45	1.43	3.57	6
2	S1+500	S2-500	21.8	80.60	0.34	1.43	0.34	1.43	3.57	
3	S2-500	S2+0	21.8	91.40	0.34	1.43	0.38	1.43	3.57	6

Opmerkingen

[6] 9.2.2 (4) 50% van de dwarskrachtwapening moet uit beugels bestaan.

5.6

BIJLAGE 6 – WAND AS 5, BG, TUSSEN AS A-C

BIJ

LA

GE



Technosoft Liggers release 6.76

17 mei 2023

Project.....: 21038 - Herman Gorterstraat

Onderdeel....: Wand as 5 BG tussen as A-C

Constructeur.: ing. **5.1, 2, e**

Dimensies....: kN/m/

Datum.....: 06/09/2022

Bestand.....: J:\Dropbox (BREEDID)\Projecten 2021\21038 - Herman
Gorterstraat\BREED ID\Calculations\5_Werkfase\wapening
wanden + keldervloer\20230516_balk as 5 BG.dlw

Betrouwbaarheidsklasse : 2 Referentieperiode : 50
 Herverdelen van momenten : nee Maximale deellengte : 0.500
 Ouderdom bij belasten : 28 Relatieve vochtigheid : 50%

Doorbuigingen(beton) zijn dmv gecorrigeerde stijfheden berekend.

Fysisch lineair : Er is gerekend met de e-modulus uit de materiaaltabel.
 Fys.NLE.kort : Er is gerekend met een gecorrigeerde e-modulus (korte duur).
 Deze e-mod. is berekend mbv de krachten uit de fysisch lineair berekening.

Toegepaste normen volgens Eurocode met Nederlandse NB

Belastingen	NEN-EN 1990:2002	C2:2010,A1:2019	NB:2019 (nl)
	NEN-EN 1991-1-1:2002	C1/C11:2019	NB:2019 (nl)
Beton	NEN-EN 1992-1-1:2011 (nl)	C2/A1:2015 (nl)	NB:2016 (nl)



GEOMETRIE

Ligger:1

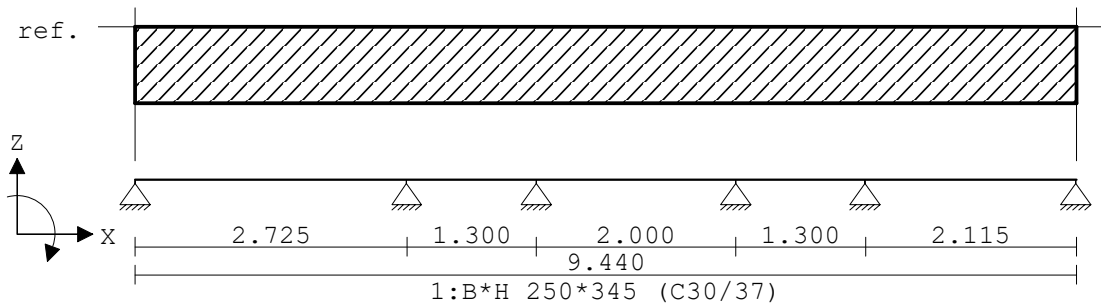

VELDLENGTEN

Ligger:1

Veld	Vanaf	Tot	Lengte
1	0.000	2.725	2.725
2	2.725	4.025	1.300
3	4.025	6.025	2.000
4	6.025	7.325	1.300
5	7.325	9.440	2.115

Project.....: 21038 - Herman Gorterstraat
 Onderdeel....: Wand as 5, BG, tussen as A-C

MATERIALEN

Mt	Kwaliteit	E-modulus[N/mm2]	S.G.	Pois.	Uitz. coëff
1	C30/37	9465	25.0	0.20	1.0000e-05

MATERIALEN vervolg

Mt	Kwaliteit	Cement	Kruipfac.
1	C30/37	N	2.47

PROFIELEN [mm]

Prof.	Omschrijving	Materiaal	Oppervlak	Traagheid	Vormf.
1	B*H 250*345	1:C30/37	8.6250e+04	8.5549e+08	0.00

PROFIELEN vervolg [mm]

Prof.	Staaftype	Breedte	Hoogte	e	Type	b1	h1	b2	h2
1	0:Normaal	250	345	172.5	0:RH				

DOORSNEDEN

Ligger:1

sector	Vanaf	Tot	Lengte	Profiel begin	z-begin	Profiel eind	z-eind
1	0.000	9.440	9.440	1:B*H 250*345	0.000	1:B*H 250*345	0.000

sector	Vanaf	Tot	Lengte	Eindcode	Bedding Br.[mm]
1	0.000	9.440	9.440	1:Vast	

PROFIELVORMEN [mm]

1 B*H 250*345



BELASTINGGEVALLEN

B.G.	Omschrijving	Belast/onbelast	Ψ_0	Ψ_1	Ψ_2	e.g.
1	Permanent	2:Permanent EN1991				0.00
2	Veranderlijk	1:Schaakbord EN1991	1.00	1.00	1.00	0.00

BELASTINGGEVALLEN

B.G.	Omschrijving	Type
1	Permanent	1 Permanente belasting
2	Veranderlijk	2 Ver. bel. pers. ed. (q_k)

Project.....: 21038 - Herman Gorterstraat
 Onderdeel....: Wand as 5, BG, tussen as A-C

VELDBELASTINGEN

Ligger:1 B.G:1 Permanent

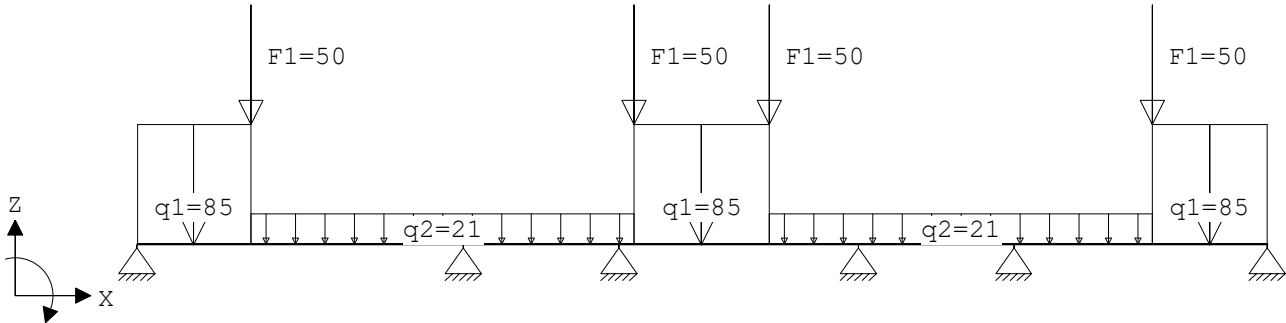

VELDBELASTINGEN

Ligger:1 B.G:1 Permanent

Last Ref.	Type	Omschrijving	q1/p/m	q2	psi	Afstand	Lengte
1	1:q-last	q1	-85.000	-85.000		0.000	0.950
2	1:q-last	q1	-85.000	-85.000		4.150	1.130
3	1:q-last	q1	-85.000	-85.000		8.480	0.960
4	1:q-last	q2	-21.000	-21.000		0.950	3.200
5	1:q-last	q2	-21.000	-21.000		5.280	3.200
6	8:Puntlast	F1	-50.000			0.950	
7	8:Puntlast	F1	-50.000			4.150	
8	8:Puntlast	F1	-50.000			5.280	
9	8:Puntlast	F1	-50.000			8.480	

VELDBELASTINGEN

Ligger:1 B.G:2 Veranderlijk

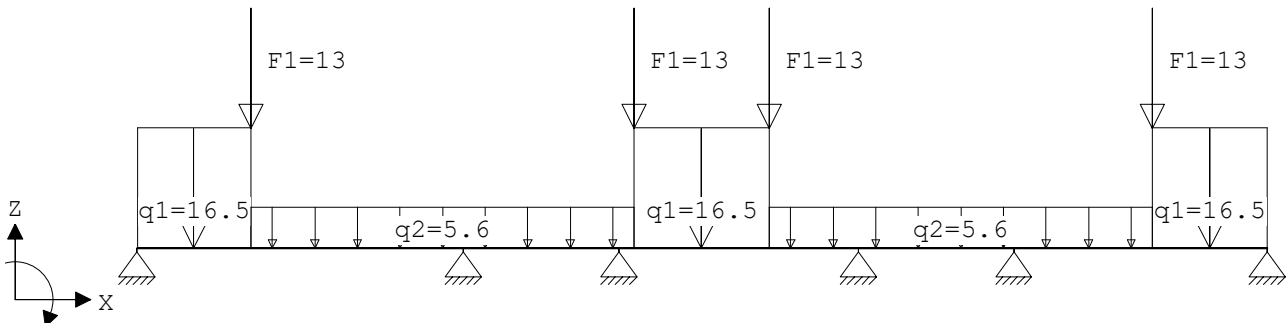

VELDBELASTINGEN

Ligger:1 B.G:2 Veranderlijk

Last Ref.	Type	Omschrijving	q1/p/m	q2	psi	Afstand	Lengte
1	1:q-last	q1	-16.500	-16.500		0.000	0.950
2	1:q-last	q1	-16.500	-16.500		4.150	1.130
3	1:q-last	q1	-16.500	-16.500		8.480	0.960
4	8:Puntlast	F1	-13.000			0.950	
5	8:Puntlast	F1	-13.000			4.150	
6	8:Puntlast	F1	-13.000			5.280	
7	8:Puntlast	F1	-13.000			8.480	
8	1:q-last	q2	-5.600	-5.600		0.950	3.200

Project.....: 21038 - Herman Gorterstraat
 Onderdeel....: Wand as 5, BG, tussen as A-C

VELDBELASTINGEN

Ligger:1 B.G:2 Veranderlijk

Last Ref.	Type	Omschrijving	q1/p/m	q2	psi	Afstand	Lengte
9	1:q-last	q2	-5.600	-5.600		5.280	3.200

BELASTINGCOMBINATIES

BC	Type	BG	Gen.	Factor	BG	Gen.	Factor	BG	Gen.	Factor	BG	Gen.	Factor
1	Fund.	1	Perm	1.35									
2	Fund.	1	Perm	1.35	2	psi0	1.50						
3	Fund.	1	Perm	1.20	2	Extr	1.50						
4	Fund.	1	Perm	0.90									
5	Fund.	1	Perm	0.90	2	psi0	1.50						
6	Fund.	1	Perm	0.90	2	Extr	1.50						
7	Kar.	1	Perm	1.00	2	Extr	1.00						
8	Freq.	1	Perm	1.00									
9	Freq.	1	Perm	1.00	2	psi1	1.00						
10	Quas.	1	Perm	1.00									
11	Quas.	1	Perm	1.00	2	psi2	1.00						
12	Blij.	1	Perm	1.00									

GUNSTIGE WERKING PERMANENTE BELASTINGEN

BC Velden met gunstige werking

- 1 Geen
- 2 Geen
- 3 Geen
- 4 Alle velden de factor:0.90
- 5 Alle velden de factor:0.90
- 6 Alle velden de factor:0.90

OMHULLENDE VAN DE FUNDAMENTELE COMBINATIES

MOMENTEN Fysisch lineair

Ligger:1 Fundamentele combinatie

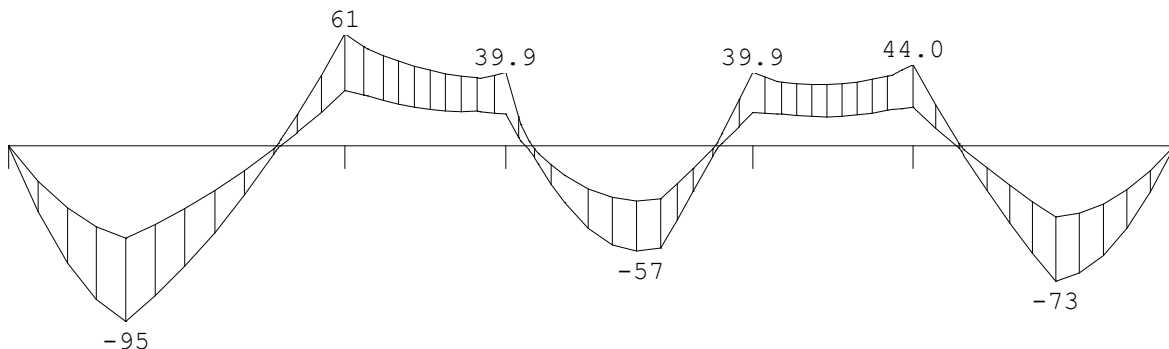

Project.....: 21038 - Herman Gorterstraat
 Onderdeel....: Wand as 5, BG, tussen as A-C

DWARSKRACHTEN Fysisch lineair Ligger:1 Fundamentele combinatie

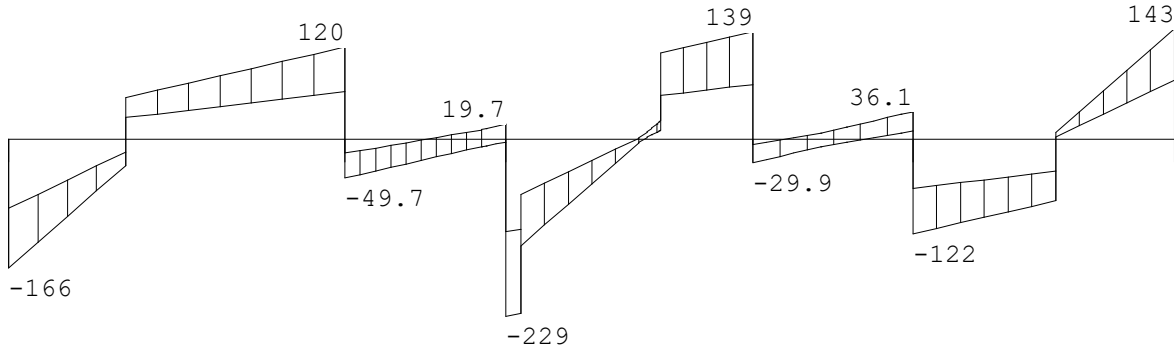

Fmin:89	80	115	78	74	76
Fmax:166	169	248	169	158	143

REACTIES Fysisch lineair Ligger:1 Fundamentele combinatie

Stp	Fmin	Fmax	Mmin	Mmax
1	88.70	165.88	0.00	0.00
2	79.53	169.29	0.00	0.00
3	114.75	248.46	0.00	0.00
4	77.51	168.97	0.00	0.00
5	73.78	157.64	0.00	0.00
6	76.50	142.94	0.00	0.00

Hoofdwapening Fysisch lineair Ligger:1 Fundamentele combinatie

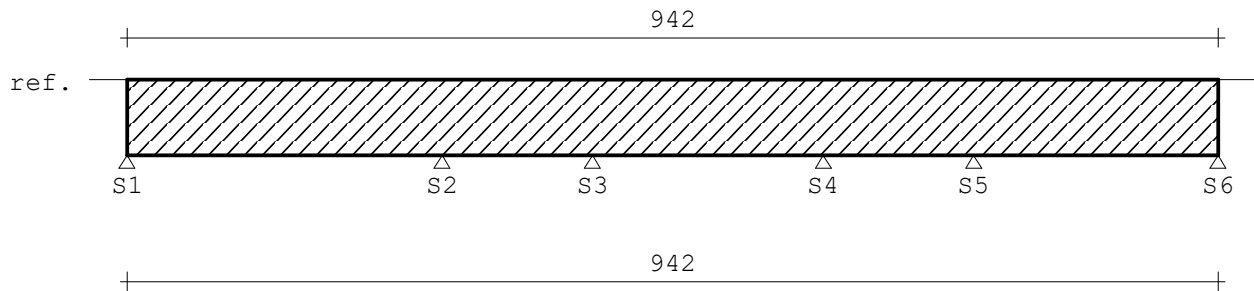

Project.....: 21038 - Herman Gorterstraat
 Onderdeel....: Wand as 5, BG, tussen as A-C

MED dekkingslijn Fysisch lineair

Ligger:1 Fundamentele combinatie

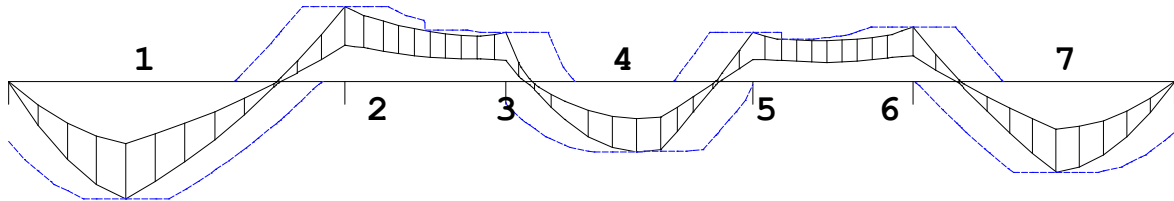

Hoofdwapening

Ligger:1

Geb.	Vanaf [mm]	Tot [mm]	M_{Ed} [kNm]	M_{Rd} [kNm]	z [mm]	B/O	A_b [mm ²]	A_a [mm ²]	Opm.
1	S1+0	S2-524	-94.63	-116.24	275	Bov	0	942	
1	S1+0	S2-524	-94.63	-116.24	275	Ond	758	943	
2	S2-557	S3-208	60.55	116.24	275	Bov	470	943	
2	S2-557	S3-208	60.55	116.24	275	Ond	0	942	
3	S3-208	S3+221	39.91	116.24	275	Bov	301	943	
3	S3-208	S3+221	39.91	116.24	275	Ond	0	942	
4	S3+162	S4-265	-56.83	-116.24	275	Bov	0	942	
4	S3+162	S4-265	-56.83	-116.24	275	Ond	439	943	
5	S4-304	S4+527	39.93	116.24	275	Bov	301	943	
5	S4-304	S4+527	39.93	116.24	275	Ond	0	942	
6	S4+527	S5+389	44.01	116.24	275	Bov	334	943	
6	S4+527	S5+389	44.01	116.24	275	Ond	0	942	
7	S5+353	S6+0	-72.94	-116.24	275	Bov	0	942	
7	S5+353	S6+0	-72.94	-116.24	275	Ond	574	943	

Opmerkingen

Alle maten zijn zonder verschuiving van de m-lijn en verankering

Scheurvorming volgens artikel 7.3.4

Ligger:1

Geb.	Pos. [mm]	Zijde	$M_{E,freq}$ [kNm]	$s_{r,max}$ [mm]	$\epsilon_{sm} - \epsilon_{cm}$ [‰]	w_k [mm]	k_x	w_{max} [mm]	U.C.	Opm.
1	S1+950	Ond	-68.63	158	1.160	0.184	1.67	0.667	0.28	
2	S2+0	Bov	43.81	158	0.680	0.108	1.67	0.667	0.16	
3	S3+0	Bov	28.80	158	0.390	0.062	1.67	0.667	0.09	
4	S4-909	Ond	-41.22	158	0.630	0.100	1.67	0.667	0.15	
5	S4+0	Bov	28.83	158	0.390	0.062	1.67	0.667	0.09	
6	S5+0	Bov	31.82	158	0.448	0.071	1.67	0.667	0.11	
7	S6-960	Ond	-52.90	158	0.856	0.136	1.67	0.667	0.20	

Project.....: 21038 - Herman Gorterstraat
 Onderdeel....: Wand as 5, BG, tussen as A-C

Dwarskrachtwapening

Ligger:1

Geb.	Vanaf [mm]	Tot [mm]	Beugels	Lengte [mm]	A _{sw} [mm ² /m]	V _{Ed} [kN]	A _{opg} [mm ²]	Opm.
1	S1+0	S2+0	Ø8-150	2725	553	165		6
2	S2+0	S3+0	Ø8-300	1300	219	50		
3	S3+0	S3+250	Ø8-100	250	764	229		6
4	S3+250	S3+850	Ø8-150	600	398	119		6
5	S3+850	S4-850	Ø8-300	300	219	36		
6	S4-850	S4+0	Ø8-150	850	464	139		6
7	S4+0	S5+0	Ø8-300	1300	219	36		
8	S5+0	S6+0	Ø8-150	2115	476	143		6

Opmerkingen

[6] 9.2.2 (4) 50% van de dwarskrachtwapening moet uit beugels bestaan.

Schuifspanningen

Ligger:1

Geb.	Vanaf [mm]	Tot [mm]	θ [°]	V _{Ed} [kN]	V _{Rd,c}	V _{Rd,s}	V _{Ed} < V _{Rd} < V _{Rd,Max} [N/mm ²]	Opm.
1	S1+0	S2+0	21.8	165.46	0.72	2.62	2.16 2.62	3.28 6
2	S2+0	S3+0	21.8	49.54	0.72	1.31	0.65 1.31	3.28
3	S3+0	S3+250	21.8	228.64	0.72	3.94	2.99 3.28	3.28 6
4	S3+250	S3+850	21.8	119.30	0.72	2.62	1.56 2.62	3.28 6
5	S3+850	S4-850	21.8	35.60	0.72	1.31	0.47 1.31	3.28
6	S4-850	S4+0	21.8	139.00	0.72	2.62	1.82 2.62	3.28 6
7	S4+0	S5+0	21.8	35.99	0.72	1.31	0.47 1.31	3.28
8	S5+0	S6+0	21.8	142.52	0.72	2.62	1.86 2.62	3.28 6

Opmerkingen

[6] 9.2.2 (4) 50% van de dwarskrachtwapening moet uit beugels bestaan.

Toetsing doorbuiging

Veld	Mtg	Lengte [m]	Type	w _{tot} [mm]	Zeeg [mm]	w [mm]	--Toel.1-- [mm]	Toel.2 *L	u.c. [mm]	
1	db	2.72	Quasi-Blijvend Eind	-3.9	0	-3.9	10.9	0.004	20.0	0.36
			Frequent Bijk				-2.0	5.5	0.002	15.0
2	db	1.30	Quasi-Blijvend Eind	0.6	0	0.6	5.2	0.004	20.0	0.12
			Frequent Bijk				0.4	2.6	0.002	15.0
3	db	2.00	Quasi-Blijvend Eind	-1.4	0	-1.4	8.0	0.004	20.0	0.18
			Frequent Bijk				-0.9	4.0	0.002	15.0
4	db	1.30	Quasi-Blijvend Eind	0.5	0	0.5	5.2	0.004	20.0	0.10
			Frequent Bijk				0.3	2.6	0.002	15.0
5	db	2.12	Quasi-Blijvend Eind	-1.9	0	-1.9	8.5	0.004	20.0	0.23
			Frequent Bijk				-1.1	4.2	0.002	15.0

Project.....: 21038 - Herman Gorterstraat
Onderdeel....: Wand as 5, BG, tussen as A-C

DOORBUIGINGEN w1 [mm]

Ligger:1 Blijvende combinatie

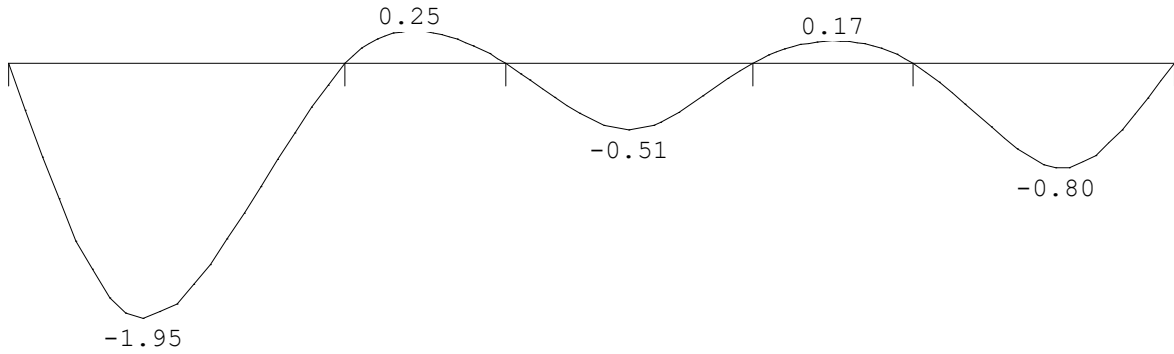

DOORBUIGINGEN w2 [mm]

Ligger:1 Quasi-blijvende combinatie

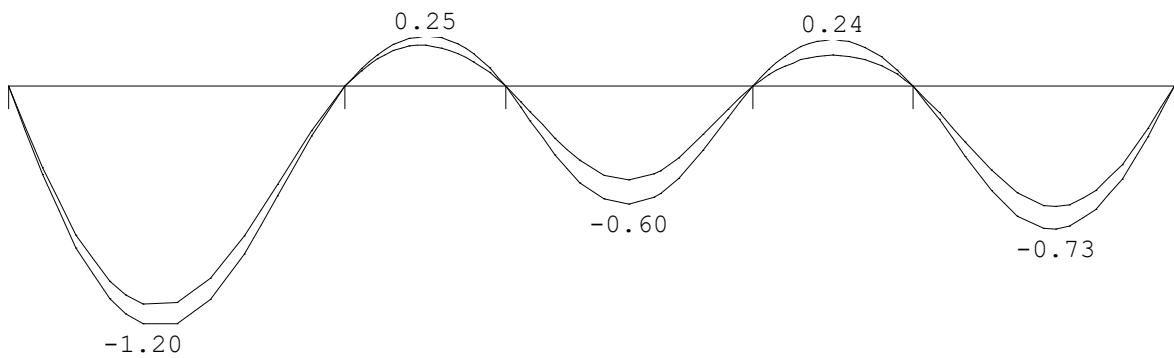

DOORBUIGINGEN wbij [mm]

Ligger:1 Karakteristieke combinatie

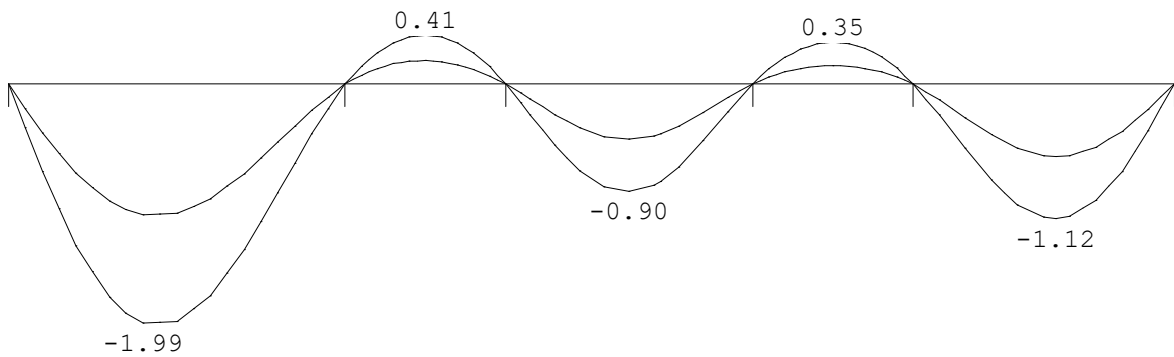

Project.....: 21038 - Herman Gorterstraat
 Onderdeel....: Wand as 5, BG, tussen as A-C

DOORBUIGINGEN W_{max} [mm]

Ligger:1 Karakteristieke combinatie

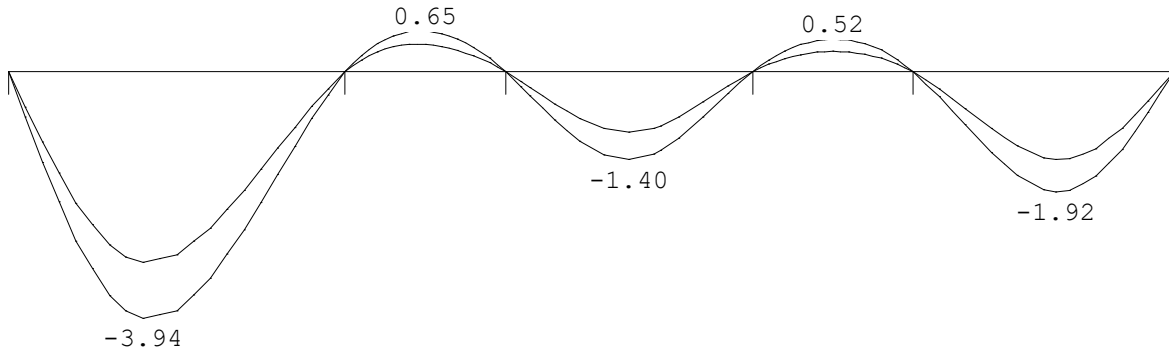

DOORBUIGINGEN

Karakteristieke combinatie

Veld	Zijde	positie [m]	l_{rep} [mm]	w_1 [mm]	w_2 [mm]	-- w_{bij} -- [mm] [lrep/]	w_{tot} [mm]	w_c [mm]	-- w_{max} -- [mm] [lrep/]	
1	Neg.	1.090	2725	-2.0	-1.2	-2.0	1369	-3.9	-3.9	691
2	Pos.	0.650	1300	0.2	0.3	0.4	3193	0.6	0.6	2005
3	Neg.	1.000	2000	-0.5	-0.6	-0.9	2228	-1.4	-1.4	1424
4	Pos.	0.650	1300	0.2	0.2	0.3	3730	0.5	0.5	2501
5	Neg.	1.155	2115	-0.8	-0.7	-1.1	1886	-1.9	-1.9	1101

DOORBUIGINGEN W_{bij} [mm]

Ligger:1 Frequente combinatie

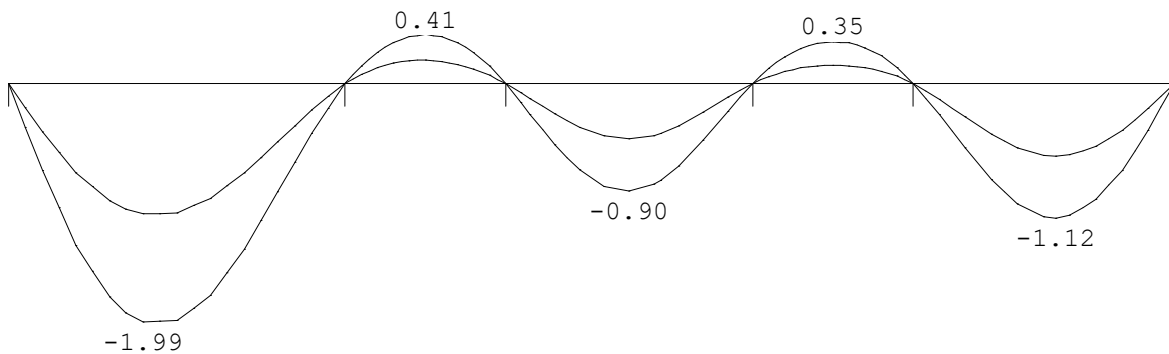

Project.....: 21038 - Herman Gorterstraat
 Onderdeel....: Wand as 5, BG, tussen as A-C

DOORBUIGINGEN W_{max} [mm]

Ligger:1 Frequente combinatie

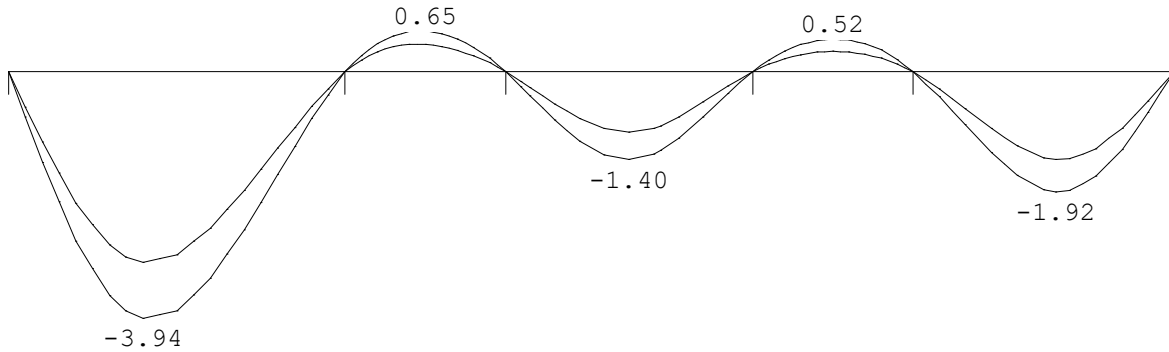

DOORBUIGINGEN

Frequente combinatie

Veld	Zijde	positie [m]	l_{rep} [mm]	w_1 [mm]	w_2 [mm]	w_{bij} [mm]	l_{rep} [mm]	w_{tot} [mm]	w_c [mm]	w_{max} [mm]	l_{rep} [mm]
1	Neg.	1.090	2725	-2.0	-1.2	-2.0	1369	-3.9	-3.9	691	
2	Pos.	0.650	1300	0.2	0.3	0.4	3193	0.6	0.6	2005	
3	Neg.	1.000	2000	-0.5	-0.6	-0.9	2228	-1.4	-1.4	1424	
4	Pos.	0.650	1300	0.2	0.2	0.3	3730	0.5	0.5	2501	
5	Neg.	1.155	2115	-0.8	-0.7	-1.1	1886	-1.9	-1.9	1101	

DOORBUIGINGEN w_{bij} [mm]

Ligger:1 Quasi-blijvende combinatie

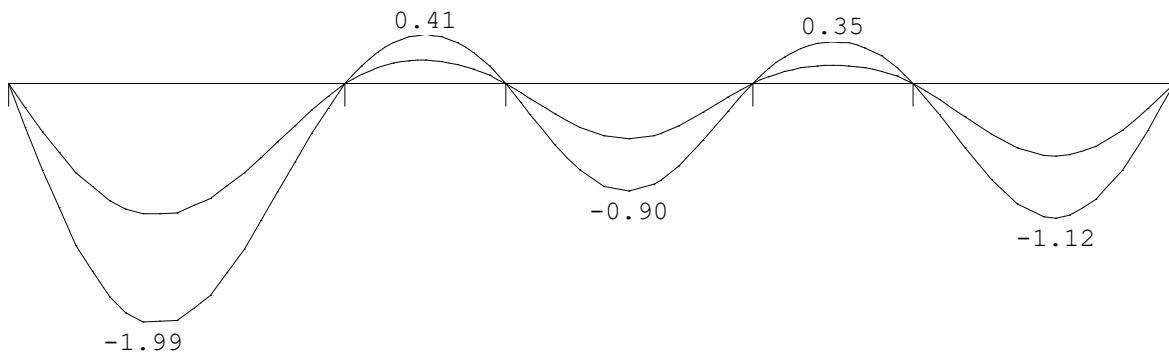

Project.....: 21038 - Herman Gorterstraat
 Onderdeel....: Wand as 5, BG, tussen as A-C

DOORBUIGINGEN Wmax [mm]

Ligger:1 Quasi-blijvende combinatie

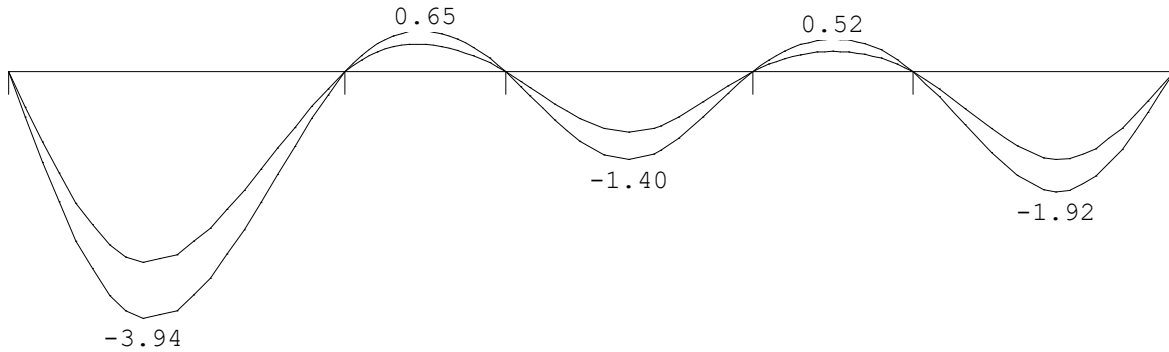

DOORBUIGINGEN

Quasi-blijvende combinatie

Veld	Zijde	positie [m]	l_{rep} [mm]	w_1 [mm]	w_2 [mm]	-- w_{bij} -- [mm] [lrep/]	w_{tot} [mm]	w_c [mm]	-- w_{max} -- [mm] [lrep/]
1	Neg.	1.090	2725	-2.0	-1.2	-2.0	1369	-3.9	-3.9 691
2	Pos.	0.650	1300	0.2	0.3	0.4	3193	0.6	0.6 2005
3	Neg.	1.000	2000	-0.5	-0.6	-0.9	2228	-1.4	-1.4 1424
4	Pos.	0.650	1300	0.2	0.2	0.3	3730	0.5	0.5 2501
5	Neg.	1.155	2115	-0.8	-0.7	-1.1	1886	-1.9	-1.9 1101

5.7

BIJLAGE 7 – WAND AS 5, 1^E VERD., TUSSEN AS A-C

BIJ

LA

GE



Technosoft Liggers release 6.76 17 mei 2023
 Project.....: 21038 - Herman Gorterstraat
 Onderdeel....: Wan 5
 Constructeur.: ir. **5.1, 2, e**
 Dimensies....: kN/m/rad
 Datum.....: 08/12/2021
 Bestand.....: J:\Dropbox (BREEDID)\Projecten 2021\21038 - Herman
 Gorterstraat\BREED ID\Calculations\5_Werkfase\wapening
 wanden + keldervloer\20230511_balk dak as 4 + 1e as 5.dlw

Betrouwbaarheidsklasse : 2 Referentieperiode : 50
 Herverdelen van momenten : nee Maximale deellengte : 0.000
 Ouderdom bij belasten : 28 Relatieve vochtigheid : 50%
 Doorbuigingen(beton) zijn dmv gecorrigeerde stijfheden berekend.

Fysisch lineair : Er is gerekend met de e-modulus uit de materiaaltabel.
 Fys.NLE.kort : Er is gerekend met een gecorrigeerde e-modulus (korte duur).
 Deze e-mod. is berekend mbv de krachten uit de fysisch lineair berekening.

Toegepaste normen volgens Eurocode met Nederlandse NB

Belastingen	NEN-EN 1990:2002	C2:2010,A1:2019	NB:2019(nl)
	NEN-EN 1991-1-1:2002	C1/C11:2019	NB:2019(nl)
Beton	NEN-EN 1992-1-1:2011(nl)	C2/A1:2015(nl)	NB:2016(nl)



LIGGER:6 balk 1e verd. stram 5

Toevallige inklemmingen begin : 15% Toevallige inklemming eind : 15%

GEOMETRIE

Ligger:6 balk 1e verd. stram 5

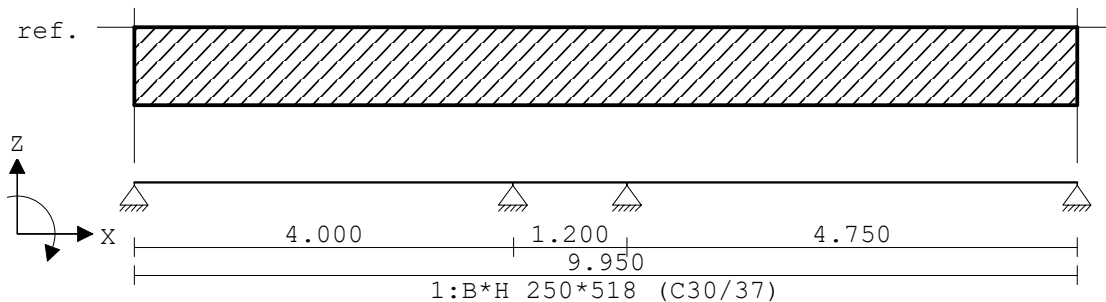

VELDLENGHTEN

Ligger:6 balk 1e verd. stram 5

Veld	Vanaf	Tot	Lengte
1	0.000	4.000	4.000
2	4.000	5.200	1.200
3	5.200	9.950	4.750

Project.....: 21038 - Herman Gorterstraat

Onderdeel....: Wand as 5

MATERIALEN

Mt	Kwaliteit	E-modulus[N/mm2]	S.G.	Pois.	Uitz. coëff
1	C30/37	9465	25.0	0.20	1.0000e-05

MATERIALEN vervolg

Mt	Kwaliteit	Cement	Kruipfac.
1	C30/37	N	2.47

PROFIELEN [mm]

Prof.	Omschrijving	Materiaal	Oppervlak	Traagheid	Vormf.
1	B*H 250*518	1:C30/37	1.2950e+05	2.8957e+09	0.00
2	B*H 800*452	1:C30/37	3.6160e+05	6.1564e+09	0.00

PROFIELEN vervolg [mm]

Prof.	Staaftype	Breedte	Hoogte	e	Type	b1	h1	b2	h2
1	0:Normaal	250	518	259.0	0:RH				
2	0:Normaal	800	452	226.0	0:RH				

DOORSNEDEN

Ligger:6 balk 1e verd. stram 5

sector	Vanaf	Tot	Lengte	Profiel begin	z-begin	Profiel eind	z-eind
1	0.000	9.950	9.950	1:B*H 250*518	0.000	1:B*H 250*518	0.000

sector	Vanaf	Tot	Lengte	Eindcode	Bedding Br. [mm]
1	0.000	9.950	9.950	1:Vast	

PROFIELVORMEN [mm]

1 B*H 250*518



2 B*H 800*452



BELASTINGGEVALLEN

B.G.	Omschrijving	Belast/onbelast	ψ_0	ψ_1	ψ_2	e.g.
1	Permanent	2:Permanent EN1991				-1.00
2	Veranderlijk	1:Schaakbord EN1991	0.40	0.70	0.60	0.00

Project.....: 21038 - Herman Gorterstraat

Onderdeel....: Wand as 5

BELASTINGCOMBINATIES

BC Type	BG Gen. Factor	BG Gen. Factor	BG Gen. Factor	BG Gen. Factor
9 Freq.	1 Perm	1.00	2 psi1	1.00
10 Quas.	1 Perm	1.00		
11 Quas.	1 Perm	1.00	2 psi2	1.00
12 Blij.	1 Perm	1.00		

GUNSTIGE WERKING PERMANENTE BELASTINGEN

- BC Velden met gunstige werking
- 1 Geen
 - 2 Geen
 - 3 Geen
 - 4 Alle velden de factor:0.90
 - 5 Alle velden de factor:0.90
 - 6 Alle velden de factor:0.90

OMHULLENDE VAN DE FUNDAMENTELE COMBINATIES

MOMENTEN Fysisch lineair Ligger:6 balk 1e verd. stram 5 Fundamentele combinatie

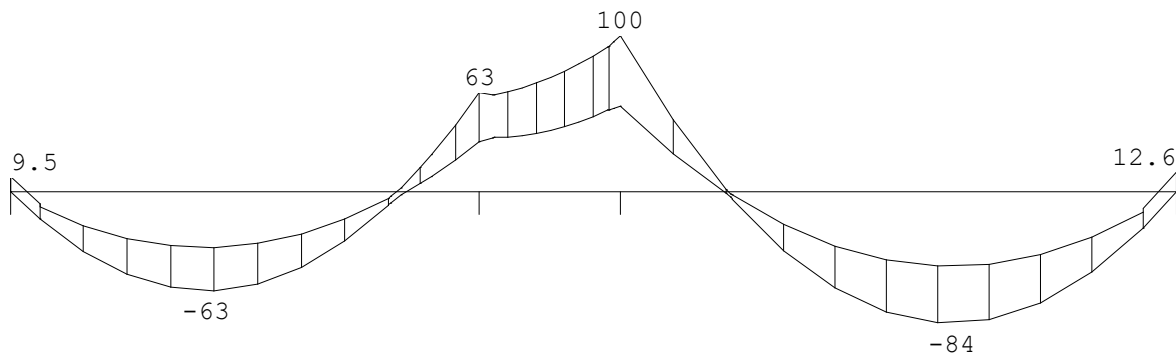

DWARSKRACHTEN Fysisch lineair Ligger:6 balk 1e verd. stram 5 Fundamentele combinatie

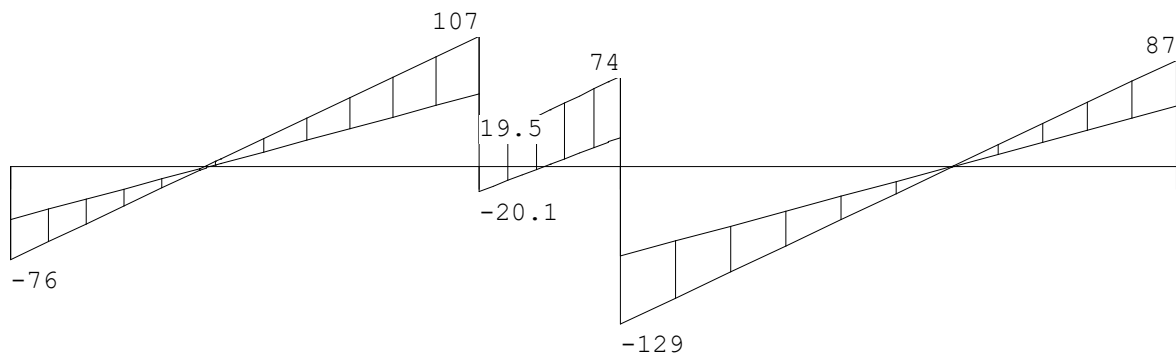

Fmin:43.0
Fmax:76

41.0 97
126 203

49.6
87

Project.....: 21038 - Herman Gorterstraat

Onderdeel....: Wand as 5

REACTIES Fysisch lineair Ligger:6 balk 1e verd. stram 5 Fundamentele combinatie

Stp	Fmin	Fmax	Mmin	Mmax
1	43.01	75.85	0.00	0.00
2	40.95	126.04	0.00	0.00
3	96.99	202.89	0.00	0.00
4	49.63	87.38	0.00	0.00

Hoofdwapening Fysisch lineair Ligger:6 balk 1e verd. stram 5 Fundamentele combinatie

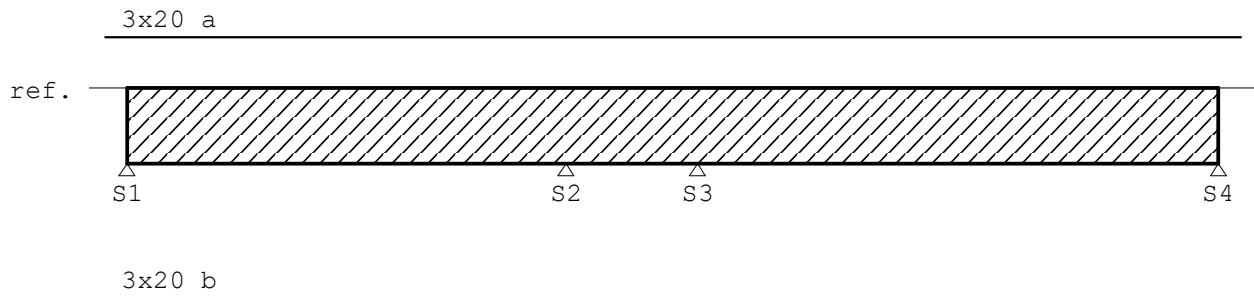

MEd dekkingslijn Fysisch lineair Ligger:6 balk 1e verd. stram 5 Fundamentele combinatie

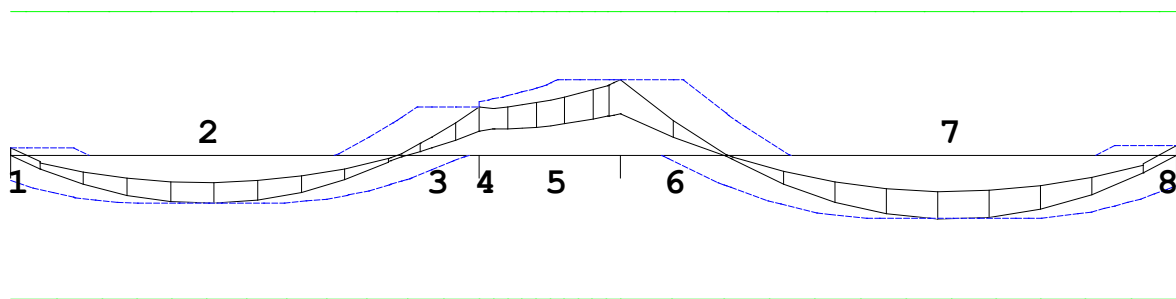

Hoofdwapening

Ligger:6 balk 1e verd. stram 5

Geb.	Pos. [mm]	M _{Ed} [kNm]	M _{Rd} [kNm]	z B/O [mm]	A _b [mm ²]	A _a [mm ²]	Basiswapening +Bijlegwapening	Opm.
1	S1+0	9.50	189.26	442 Bov	151*	943	3x20	54
2	S1+1669	-63.31	-189.26	442 Ond	304	943	3x20	
3	S2-0	63.38	189.26	442 Bov	304	943	3x20	
4	S2+0	70.61	189.26	442 Bov	340	943	3x20	2,68
5	S3-0	99.56	189.26	442 Bov	486	943	3x20	2,68
6	S3-0	99.56	189.26	442 Bov	486	943	3x20	
7	S4-1923	-84.03	-189.26	442 Ond	407	943	3x20	
8	S4-0	12.60	189.26	442 Bov	151*	943	3x20	54

Project.....: 21038 - Herman Gorterstraat

Onderdeel....: Wand as 5

Hoofdwapening

Ligger:6 balk 1e verd. stram 5

Geb.	Pos. [mm]	M_{Ed} [kNm]	M_{Rd} [kNm]	z B/O [mm]	A_b [mm ²]	A_a [mm ²]	Basiswapening +Bijlegwapening	Opm.
------	--------------	-------------------	-------------------	---------------	-----------------------------	-----------------------------	----------------------------------	------

Opmerkingen

[2] Benodigde wapening en inwendige hefboomsarm zijn bepaald volgens gedrongen ligger detaillering, zie nationale bijlage art. 6.1(10).

[54] * = Eisen met betrekking tot minimum wapening ten behoeve van gecontroleerde scheurvorming zijn toegepast volgens art. 7.3.2.

[68] MRd als gevolg van de gedrongen ligger berekening (NB. 6.1(10)) is groter dan MRd volgens 6.1(P). De momentweerstand en inwendige hefboomsarm volgens 6.1(P) zijn maatgevend en daarom alsnog toegepast.

Scheurvorming volgens artikel 7.3.4

Ligger:6 balk 1e verd. stram 5

Geb.	Pos. [mm]	Zijde	$M_{E;freq}$ [kNm]	$s_{r,max}$ [mm]	$\epsilon_{sm}-\epsilon_{cm}$ [%]	w_k [mm]	k_x	w_{max} [mm]	U.C.	Opm.
1	S2-352	Bov	46.41	209	0.365	0.076	1.32	0.528	0.14	
1	S1+1669	Ond	-47.12	209	0.373	0.078	1.32	0.528	0.15	
2	S3-435	Bov	73.69	209	0.697	0.146	1.32	0.528	0.28	
3	S3+463	Bov	73.69	209	0.697	0.146	1.32	0.528	0.28	
3	S4-1923	Ond	-62.56	209	0.561	0.117	1.32	0.528	0.22	

Dwarskrachtwapening

Ligger:6 balk 1e verd. stram 5

Geb.	Vanaf [mm]	Tot [mm]	Beugels	Lengte [mm]	A_{sw} [mm ² /m]	V_{Ed} [kN]	A_{opg} [mm ²]	Opm.
1	S1+0	S1+200	Ø8-300	200	219	76		6
2	S1+200	S2-1100	Ø8-300	2700	219	67		
3	S2-1100	S2+0	Ø8-300	1100	222	107		6
4	S2+0	S3-300	Ø8-300	900	219	60		58
5	S3-300	S3-0	Ø8-300	300	219	74		6,58
6	S3-0	S3+1475	Ø8-300	1475	268	129		6
7	S3+1475	S4-575	Ø8-300	2700	219	62		
8	S4-575	S4+0	Ø8-300	575	219	87		6

Opmerkingen

[6] 9.2.2 (4) 50% van de dwarskrachtwapening moet uit beugels bestaan.

[58] 6.2.3: Z is berekend m.b.v. 0.9d

Schuifspanningen

Ligger:6 balk 1e verd. stram 5

Geb.	Vanaf [mm]	Tot [mm]	θ [°]	V_{Ed} [kN]	$V_{Rd,C}$	$V_{Rd,S}$	$V_{Ed} < V_{Rd} < V_{Rd,Max}$ [N/mm ²]	Opm.		
1	S1+0	S1+200	21.8	75.71	0.57	1.36	0.64	1.36	3.39	6
2	S1+200	S2-1100	21.8	66.63	0.57	1.36	0.56	1.36	3.39	

Project.....: 21038 - Herman Gorterstraat

Onderdeel....: Wand as 5

Schuifspanningen

Ligger:6 balk 1e verd. stram 5

Geb.	Vanaf [mm]	Tot [mm]	θ [°]	V_{Ed} [kN]	$V_{Rd,c}$	$V_{Rd,s}$	$V_{Ed} < V_{Rd} < V_{Rd,Max}$ [N/mm ²]			Opm.
3	S2-1100	S2+0	21.8	106.58	0.57	1.36	0.90	1.36	3.39	6
4	S2+0	S3-300	21.8	60.25	0.57	1.31	0.51	1.31	3.28	58
5	S3-300	S3-0	21.8	73.88	0.57	1.31	0.62	1.31	3.28	6,58
6	S3-0	S3+1475	21.8	128.73	0.57	1.36	1.08	1.36	3.39	6
7	S3+1475	S4-575	21.8	61.72	0.57	1.36	0.52	1.36	3.39	
8	S4-575	S4+0	21.8	87.25	0.57	1.36	0.73	1.36	3.39	6

Opmerkingen

[6] 9.2.2 (4) 50% van de dwarskrachtwapening moet uit beugels bestaan.

[58] 6.2.3: Z is berekend m.b.v. 0.9d

Toetsing doorbuiging

Veld	Mtg	Lengte [m]	Type	wtot [mm]	Zeeg [mm]	w [mm]	--Toel.1-- *L		Toel.2 u.c. [mm]	
1	db	4.00	Karakteristiek Eind	-1.3	8	6.7	16.0	0.004	20.0	0.42
	db		Frequent Bijk				-1.5	8.0	0.002	15.0
2	db	1.20	Karakteristiek Eind	0.4	2	2.8	4.8	0.004	20.0	0.58
	db		Frequent Bijk				0.2	2.4	0.002	15.0
3	db	4.75	Karakteristiek Eind	-3.1	10	6.3	19.0	0.004	20.0	0.33
	db		Frequent Bijk				-2.6	9.5	0.002	15.0

DOORBUIGINGEN w1 [mm] Ligger:6 balk 1e verd. stram 5 Blijvende combinatie

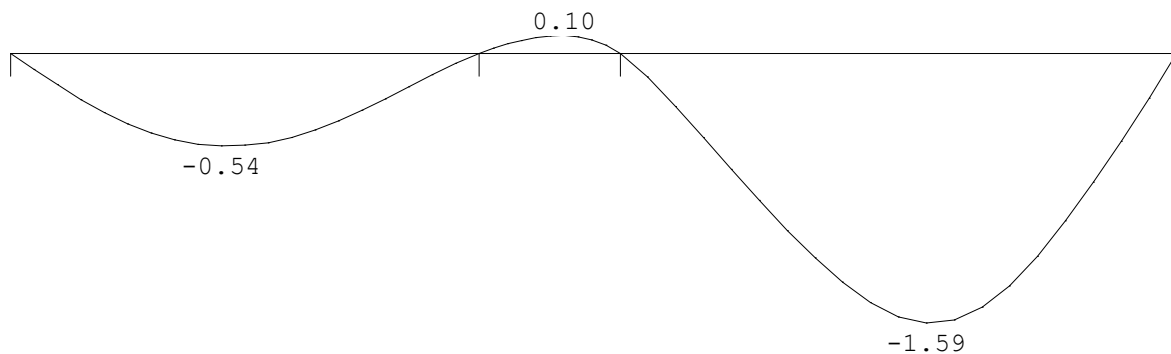

Project.....: 21038 - Herman Gorterstraat

Onderdeel....: Wand as 5

DOORBUIGINGEN w2 [mm] Ligger:6 balk 1e verd. stram 5 Quasi-blijvende combinatie

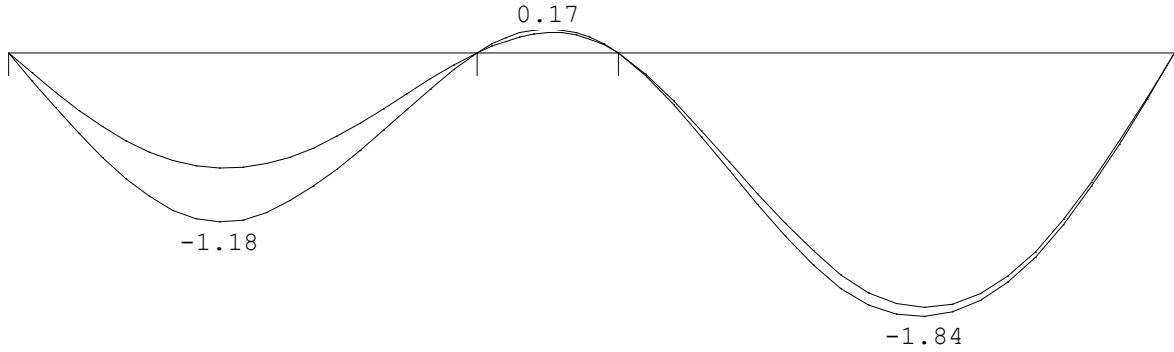

DOORBUIGINGEN w_{bij} [mm] Ligger:6 balk 1e verd. stram 5 Karakteristieke combinatie

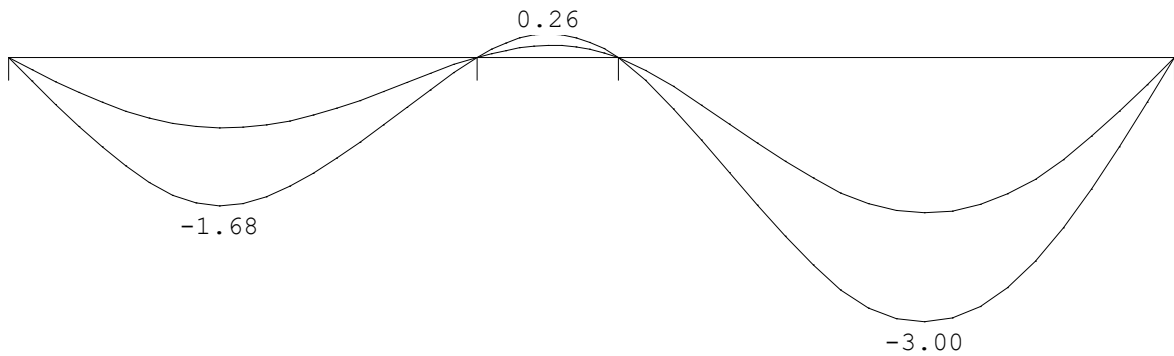

DOORBUIGINGEN w_{tot} [mm] Ligger:6 balk 1e verd. stram 5 Karakteristieke combinatie

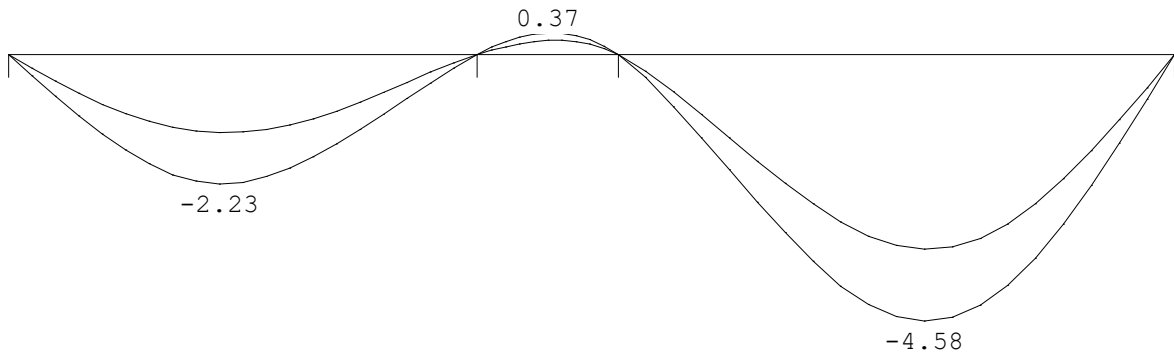

Project.....: 21038 - Herman Gorterstraat

Onderdeel....: Wand as 5

DOORBUIGINGEN w_{max} Ligger:6 balk 1e verd. stram 5 Karakteristieke combinatie

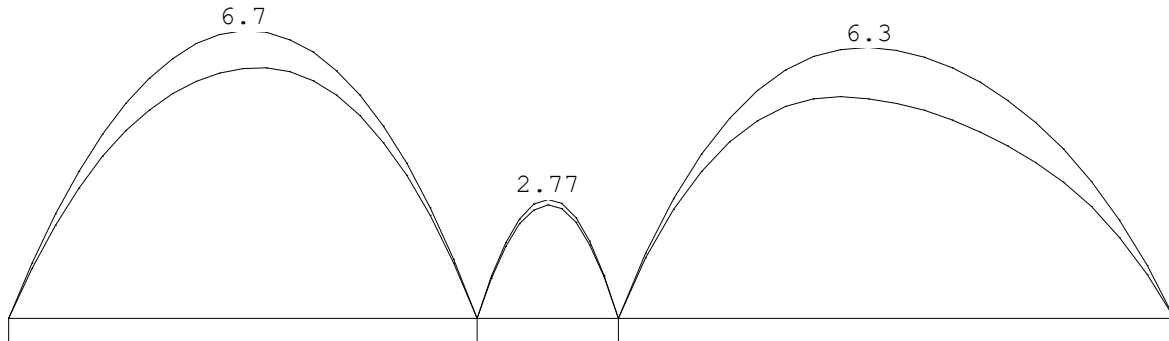

DOORBUIGINGEN

Karakteristieke combinatie

Veld	Zijde	positie [m]	l_{rep} [mm]	w_1 [mm]	w_2 [mm]	w_{bij} [mm]	w_{tot} [mm]	w_c [mm]	w_{max} [mm]
1	Neg.	1.800	4000	-0.5	-1.2	-1.7	2375	-2.2	703
1	Pos.	2.000	4000	-0.5	-0.8	-0.8	5031	-1.3	600
2	Pos.	0.600	1200	0.1	0.2	0.3	4563	0.4	434
3	Neg.	2.612	4750	-1.6	-1.8	-3.0	1585	-4.6	985
3	Pos.	2.137	4750	-1.5	-1.7	-1.7	2860	-3.1	757

DOORBUIGINGEN w_{bij} [mm] Ligger:6 balk 1e verd. stram 5 Frequente combinatie

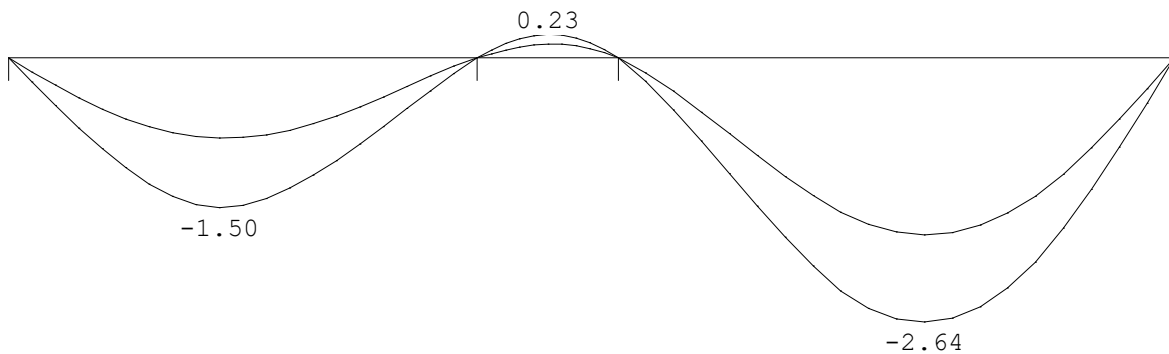

Project.....: 21038 - Herman Gorterstraat

Onderdeel....: Wand as 5

DOORBUIGINGEN W_{tot} [mm] Ligger:6 balk 1e verd. stram 5 Frequente combinatie

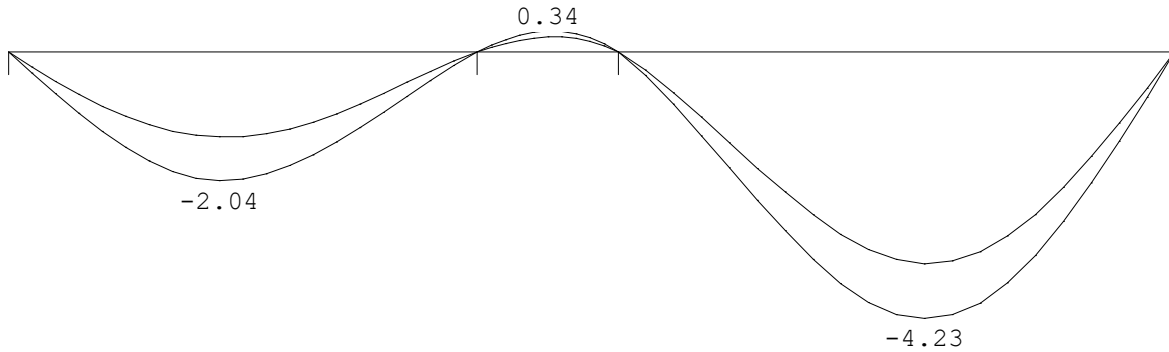

DOORBUIGINGEN W_{max} [mm] Ligger:6 balk 1e verd. stram 5 Frequente combinatie

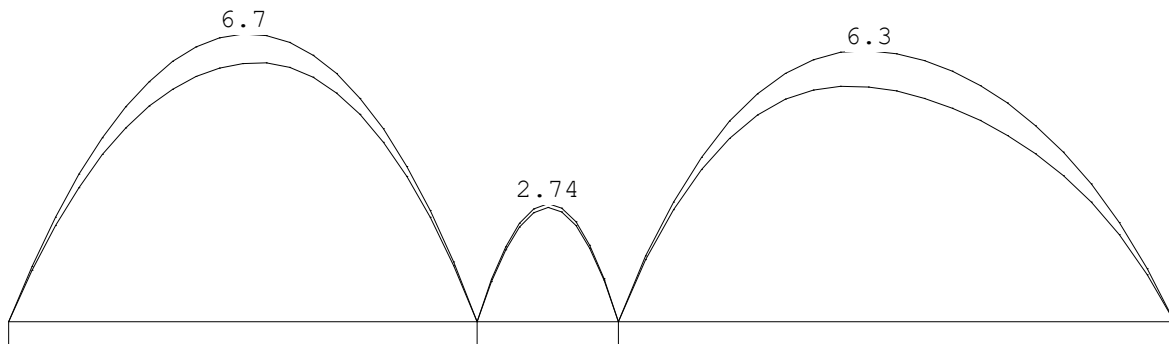

DOORBUIGINGEN

Frequente combinatie

Veld	Zijde	positie [m]	l_{rep} [mm]	w_1 [mm]	w_2 [mm]	w_{bij} [mm]	[lrep/]	w_{tot} [mm]	w_c [mm]	w_{max} [mm]	[lrep/]
1	Neg.	1.800	4000	-0.5	-1.2	-1.5	2673	-2.0	7.9	5.9	680
1	Pos.	2.000	4000	-0.5	-0.8	-0.8	5018	-1.3	8.0	6.7	600
2	Pos.	0.600	1200	0.1	0.2	0.2	5149	0.3	2.4	2.7	439
3	Neg.	2.612	4750	-1.6	-1.8	-2.6	1798	-4.2	9.4	5.2	918
3	Pos.	2.137	4750	-1.5	-1.7	-1.7	2852	-3.1	9.4	6.3	757

Project.....: 21038 - Herman Gorterstraat

Onderdeel....: Wand as 5

DOORBUIGINGEN

Quasi-blijvende combinatie

Veld	Zijde	positie	l_{rep}	w_1	w_2	w_{bij}	w_{tot}	w_c	w_{max}		
		[m]	[mm]	[mm]	[mm]	[mm] [lrep/]	[mm]	[mm]	[mm] [lrep/]		
1	Neg.	1.800	4000	-0.5	-1.2	-1.4	2782	-2.0	7.9	5.9	674
1	Pos.	2.000	4000	-0.5	-0.8	-0.8	5014	-1.3	8.0	6.7	601
2	Pos.	0.600	1200	0.1	0.2	0.2	5383	0.3	2.4	2.7	440
3	Neg.	2.612	4750	-1.6	-1.8	-2.5	1880	-4.1	9.4	5.3	898
3	Pos.	2.137	4750	-1.5	-1.7	-1.7	2850	-3.1	9.4	6.3	757

5.8

BIJLAGE 8 – WAND AS 4, DAK, TUSSEN AS A-C

BIJ

LA

GE



Technosoft Liggers release 6.76 17 mei 2023
 Project.....: 21038 - Herman Gorterstraat
 Onderdeel....: Wand as 4
 Constructeur.: ir. **5.1, 2, e**
 Dimensies....: kN/
 Datum.....: 08/12/2021
 Bestand.....: J:\Dropbox (BREEDID)\Projecten 2021\21038 - Herman
 Gorterstraat\BREED ID\Calculations\5_Werkfase\wapening
 wanden + keldervloer\20230511_balk dak as 4 + 1e as 5.dlw

Betrouwbaarheidsklasse : 2 Referentieperiode : 50
 Herverdelen van momenten : nee Maximale deellengte : 0.000
 Ouderdom bij belasten : 28 Relatieve vochtigheid : 50%
 Doorbuigingen(beton) zijn dmv gecorrigeerde stijfheden berekend.

Fysisch lineair : Er is gerekend met de e-modulus uit de materiaaltabel.
 Fys.NLE.kort : Er is gerekend met een gecorrigeerde e-modulus (korte duur).
 Deze e-mod. is berekend mbv de krachten uit de fysisch lineair berekening.

Toegepaste normen volgens Eurocode met Nederlandse NB

Belastingen	NEN-EN 1990:2002	C2:2010,A1:2019	NB:2019 (nl)
	NEN-EN 1991-1-1:2002	C1/C11:2019	NB:2019 (nl)
Beton	NEN-EN 1992-1-1:2011 (nl)	C2/A1:2015 (nl)	NB:2016 (nl)



LIGGER:balk dak stramien 4

GEOMETRIE

Ligger:balk dak stramien 4

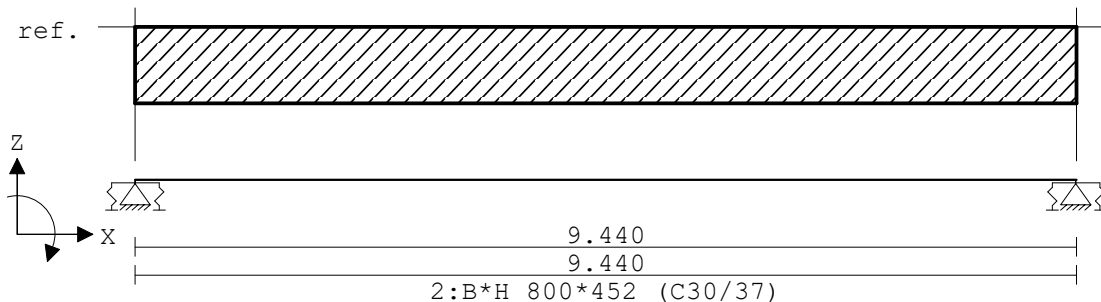

VELDLENGHTEN

Ligger:balk dak stramien 4

Veld	Vanaf	Tot	Lengte
1	0.000	9.440	9.440

Project.....: 21038 - Herman Gorterstraat

Onderdeel....: Wand as 4

MATERIALEN

Mt	Kwaliteit	E-modulus[N/mm2]	S.G.	Pois.	Uitz. coëff
1	C30/37	9465	25.0	0.20	1.0000e-05

MATERIALEN vervolg

Mt	Kwaliteit	Cement	Kruipfac.
1	C30/37	N	2.47

PROFIELEN [mm]

Prof.	Omschrijving	Materiaal	Oppervlak	Traagheid	Vormf.
1	B*H 250*518	1:C30/37	1.2950e+05	2.8957e+09	0.00
2	B*H 800*452	1:C30/37	3.6160e+05	6.1564e+09	0.00

PROFIELEN vervolg [mm]

Prof.	Staaftype	Breedte	Hoogte	e	Type	b1	h1	b2	h2
1	0:Normaal	250	518	259.0	0:RH				
2	0:Normaal	800	452	226.0	0:RH				

DOORSNEDEN

Ligger:balk dak stramien 4

sector	Vanaf	Tot	Lengte	Profiel	begin	z-begin	Profiel	eind	z-eind
1	0.000	9.440	9.440	2:B*H 800*452		0.000	2:B*H 800*452		0.000

sector	Vanaf	Tot	Lengte	Eindcode	Bedding	Br. [mm]
1	0.000	9.440	9.440	1:Vast		

PROFIELVORMEN [mm]

1 B*H 250*518



2 B*H 800*452

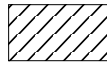

VEREN

Ligger:balk dak stramien 4

Veer	Steunpunt	Richting	Veerwaarde	Type	Ondergrens	Bovengrens
1	1	3:Rotatie	2.500e+03	Normaal	-1.000e+10	1.000e+10
2	2	3:Rotatie	2.500e+03	Normaal	-1.000e+10	1.000e+10

Project.....: 21038 - Herman Gorterstraat

Onderdeel....: Wand as 4

BELASTINGGEVALLEN

B.G.	Omschrijving	Belast/onbelast	Ψ_0	Ψ_1	Ψ_2	e.g.
1	Permanent	2:Permanent EN1991				-1.00
2	Veranderlijk	1:Schaakbord EN1991	0.40	0.70	0.60	0.00

BELASTINGGEVALLEN

B.G.	Omschrijving	Type
1	Permanent	1 Permanente belasting
2	Veranderlijk	2 Ver. bel. pers. ed. (q _k)

VELDBELASTINGEN

Ligger:balk dak stramien 4 B.G:1 Permanent

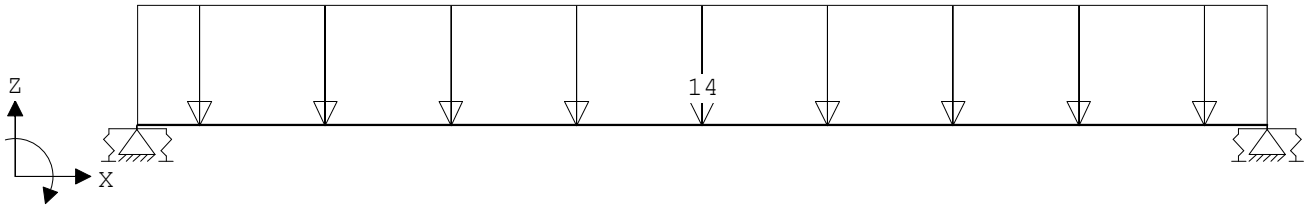

VELDBELASTINGEN

Ligger:balk dak stramien 4 B.G:1 Permanent

Last Ref.	Type	Omschrijving	q1/p/m	q2	psi	Afstand	Lengte
1	1:q-last		-14.000	-14.000		0.000	9.440

VELDBELASTINGEN

Ligger:balk dak stramien 4 B.G:2 Veranderlijk

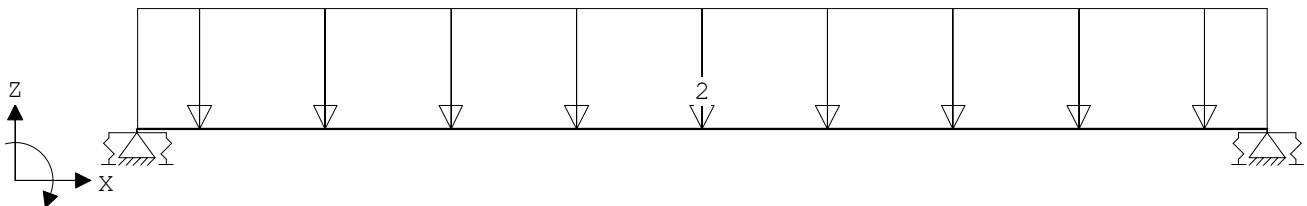

VELDBELASTINGEN

Ligger:balk dak stramien 4 B.G:2 Veranderlijk

Last Ref.	Type	Omschrijving	q1/p/m	q2	psi	Afstand	Lengte
1	1:q-last		-2.000	-2.000		0.000	9.440

BELASTINGCOMBINATIES

BC	Type	BG	Gen.	Factor	BG	Gen.	Factor	BG	Gen.	Factor	BG	Gen.	Factor
1	Fund.	1	Perm	1.35									
2	Fund.	1	Perm	1.35	2	psi0	1.50						
3	Fund.	1	Perm	1.20	2	Extr	1.50						
4	Fund.	1	Perm	0.90									
5	Fund.	1	Perm	0.90	2	psi0	1.50						
6	Fund.	1	Perm	0.90	2	Extr	1.50						

Project.....: 21038 - Herman Gorterstraat

Onderdeel....: Wand as 4

BELASTINGCOMBINATIES

BC Type	BG Gen. Factor	BG Gen. Factor	BG Gen. Factor	BG Gen. Factor
7 Kar.	1 Perm	1.00	2 Extr	1.00
8 Freq.	1 Perm	1.00		
9 Freq.	1 Perm	1.00	2 psi1	1.00
10 Quas.	1 Perm	1.00		
11 Quas.	1 Perm	1.00	2 psi2	1.00
12 Blij.	1 Perm	1.00		

GUNSTIGE WERKING PERMANENTE BELASTINGEN

- BC Velden met gunstige werking
- 1 Geen
 - 2 Geen
 - 3 Geen
 - 4 Alle velden de factor:0.90
 - 5 Alle velden de factor:0.90
 - 6 Alle velden de factor:0.90

OMHULLENDE VAN DE FUNDAMENTELE COMBINATIES

MOMENTEN Fysisch lineair Ligger:balk dak stramien 4 Fundamentele combinatie

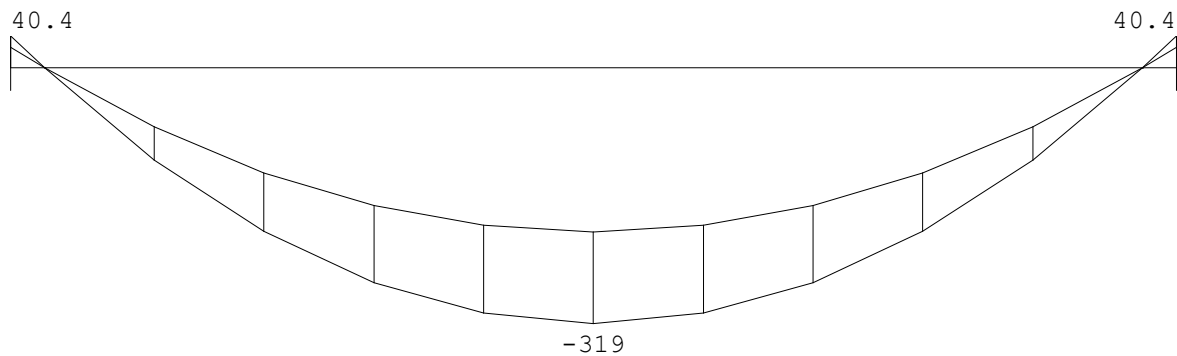

DWARSKRACHTEN Fysisch lineair Ligger:balk dak stramien 4 Fundamentele combinatie

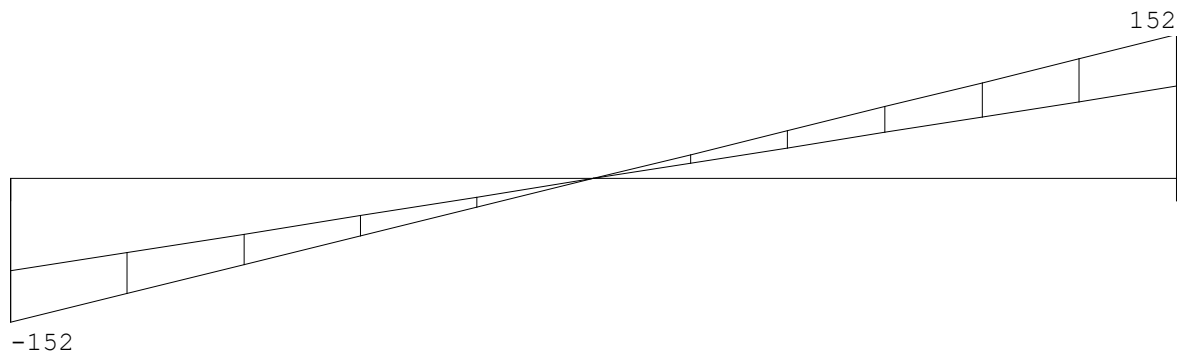

Project.....: 21038 - Herman Gorterstraat

Onderdeel....: Wand as 4

REACTIES Fysisch lineair Ligger:balk dak stramien 4 Fundamentele combinatie

Stp	Fmin	Fmax	Mmin	Mmax
1	97.87	152.47	-40.40	-25.93
2	97.87	152.47	25.93	40.40

Hoofdwapening Fysisch lineair Ligger:balk dak stramien 4 Fundamentele combinatie

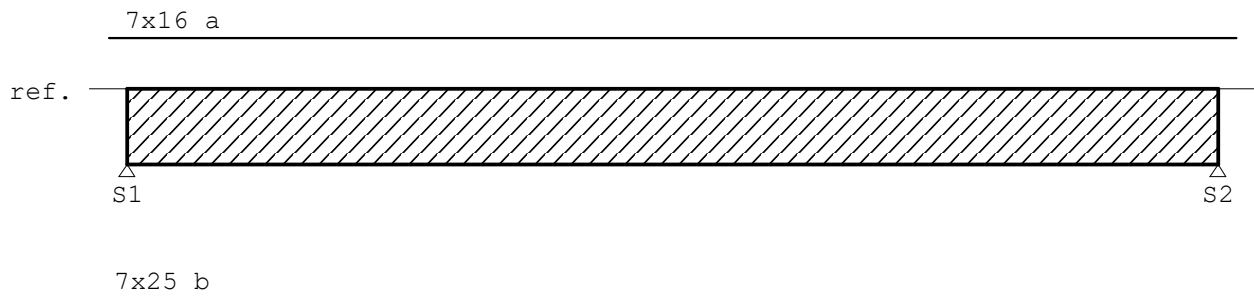

Med dekkingslijn Fysisch lineair Ligger:balk dak stramien 4 Fundamentele combinatie

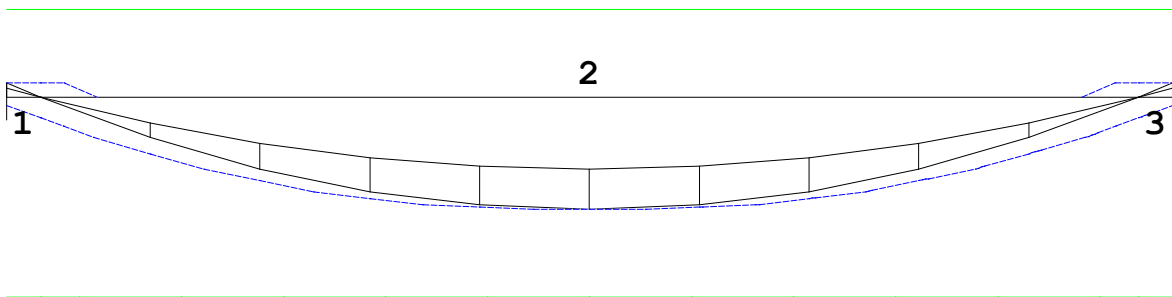

Hoofdwapening Ligger:balk dak stramien 4

Geb.	Pos. [mm]	M_{Ed} [kNm]	M_{Rd} [kNm]	z B/O [mm]	A_b [mm ²]	A_a [mm ²]	Basiswapening +Bijlegwapening	Opm.
1	S1+0	40.40	249.01	389 Bov	375*	1408	7x16	54
2	S1+4720	-319.44	-568.02	370 Ond	1871	3437	7x25	
3	S2-0	40.40	249.01	389 Bov	375*	1408	7x16	54

Opmerkingen

[54] * = Eisen met betrekking tot minimum wapening ten behoeve van gecontroleerde scheurvorming zijn toegepast volgens art. 7.3.2.

Project.....: 21038 - Herman Gorterstraat

Onderdeel....: Wand as 4

Scheurvorming volgens artikel 7.3.4

Ligger:balk dak stramien 4

Geb.	Pos. [mm]	Zijde	$M_{E;freq}$ [kNm]	$s_{r,max}$ [mm]	$\epsilon_{sm}-\epsilon_{cm}$ [%]	w_k [mm]	k_x	w_{max} [mm]	U.C.	Opm.
1	S1+0	Bov	30.56	270	0.171	0.046	1.57	0.629	0.07	
1	S1+273	Bov	30.56	270	0.171	0.046	1.57	0.629	0.07	
1	S2-273	Bov	30.56	270	0.171	0.046	1.57	0.629	0.07	
1	S2+0	Bov	30.56	270	0.171	0.046	1.57	0.629	0.07	
1	S1+4720	Ond	-241.68	222	0.771	0.172	1.10	0.440	0.39	

Dwarskrachtwapening

Ligger:balk dak stramien 4

Geb.	Vanaf [mm]	Tot [mm]	Beugels	Lengte [mm]	A_{sw} [mm ² /m]	V_{Ed} [kN]	A_{opg} [mm ²]	Opm.
1	S1+0	S2+0	Ø8-150 (4s)	9440	701	152	8	

Opmerkingen

[8] Er zijn meer dan 2 beugelsneden per doorsnede toegepast.

Schuifspanningen

Ligger:balk dak stramien 4

Geb.	Vanaf [mm]	Tot [mm]	θ [°]	V_{Ed} [kN]	$v_{Rd,c}$	$v_{Rd,s}$	$v_{Ed} < v_{Rd} < v_{Rd,Max}$ [N/mm ²]	Opm.
1	S1+0	S2+0	21.8	152.38	0.48	1.73	0.46 1.73	3.45 8

Opmerkingen

[8] Er zijn meer dan 2 beugelsneden per doorsnede toegepast.

Toetsing doorbuiging

Veld	Mtg	Lengte [m]	Type	w_{tot} [mm]	Zeeg [mm]	w [mm]	--Toel.1-- [mm]	Toel.2 u.c. *L [mm]
1	db	9.44	Karakteristiek Eind	-38.2	19	-19.3	37.8	0.004 20.0 0.97
	db		Frequent Bijk			-13.2	18.9	0.002 15.0 0.88

DOORBUIGINGEN w1 [mm]

Ligger:balk dak stramien 4 Blijvende combinatie

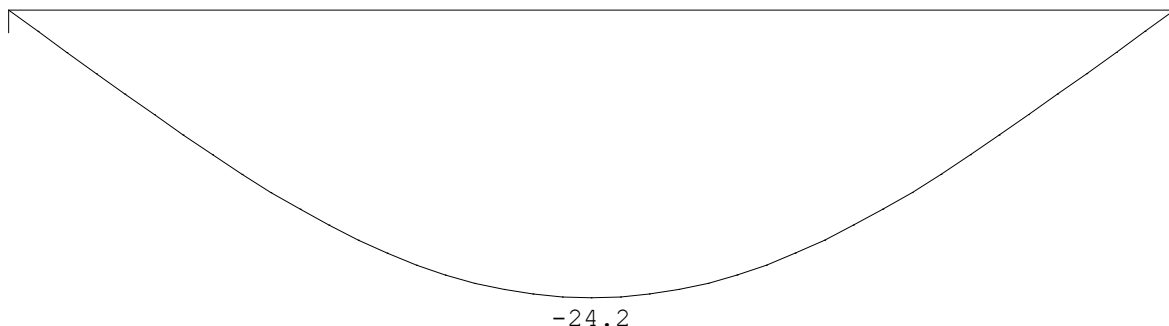

Project.....: 21038 - Herman Gorterstraat

Onderdeel....: Wand as 4

DOORBUIGINGEN w_2 [mm] Ligger:balk dak stramien 4 Quasi-blijvende combinatie

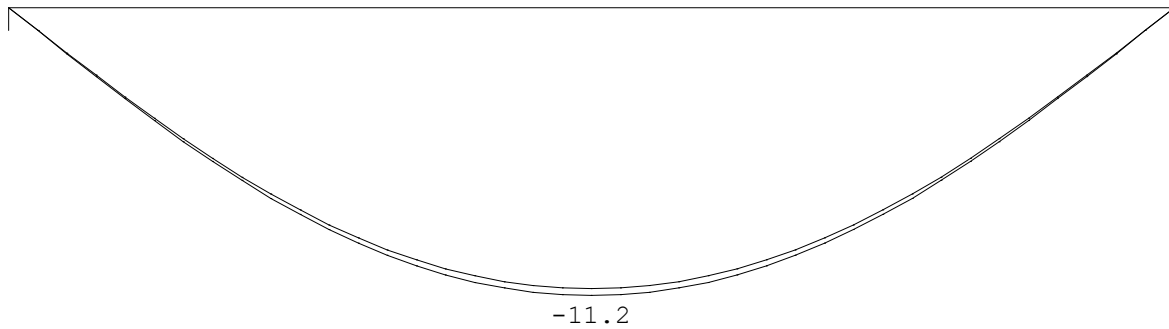

DOORBUIGINGEN w_{bij} [mm] Ligger:balk dak stramien 4 Karakteristieke combinatie

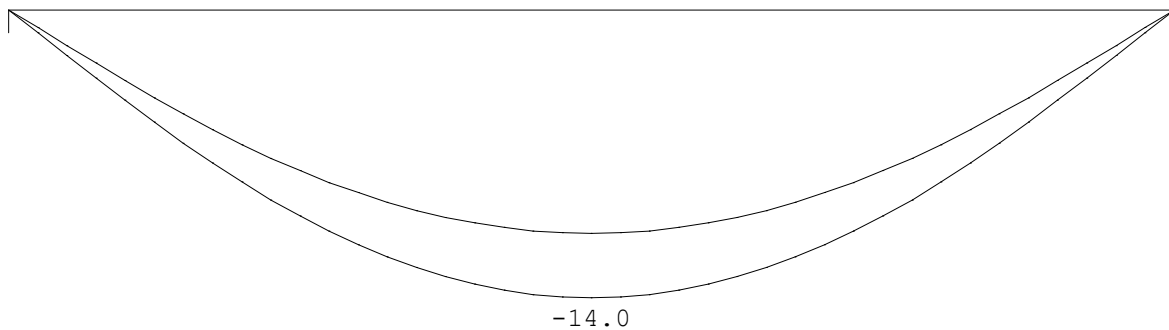

DOORBUIGINGEN w_{tot} [mm] Ligger:balk dak stramien 4 Karakteristieke combinatie

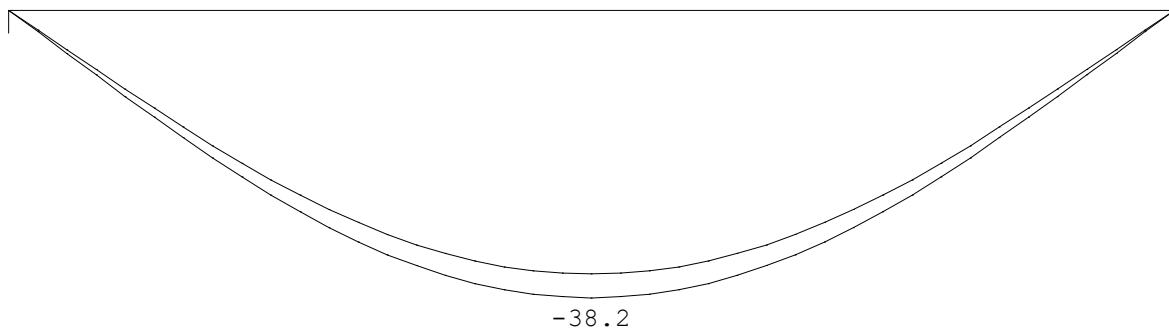

Project.....: 21038 - Herman Gorterstraat

Onderdeel....: Wand as 4

DOORBUIGINGEN Wmax [mm] Ligger:balk dak stramien 4 Karakteristieke combinatie

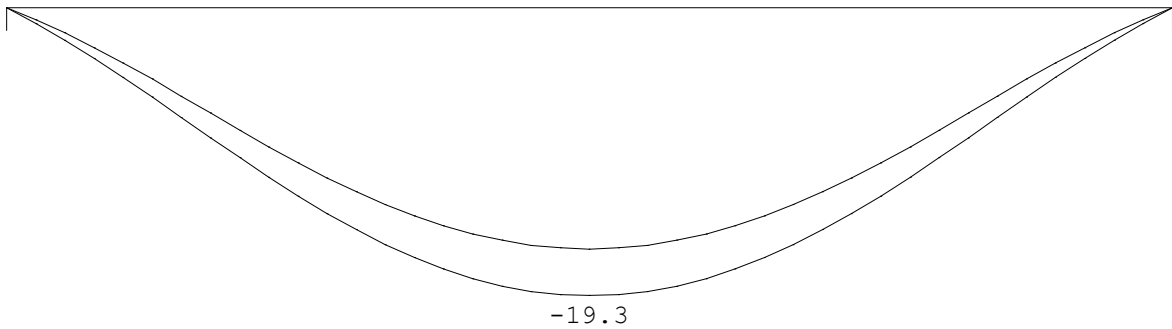

DOORBUIGINGEN Karakteristieke combinatie

Veld	Zijde	positie [m]	l_{rep} [mm]	w_1 [mm]	w_2 [mm]	w_{bij} [mm]	w_{tot} [mm]	w_c [mm]	w_{max} [mm]
1	Neg.	4.720	9440	-24.2	-11.2	-14.0	673	-38.2	18.9

DOORBUIGINGEN Wbij [mm] Ligger:balk dak stramien 4 Frequente combinatie

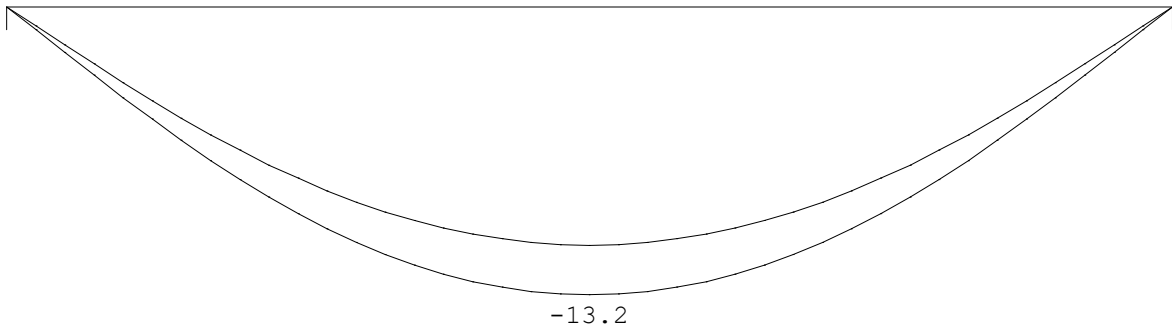

DOORBUIGINGEN Wtot [mm] Ligger:balk dak stramien 4 Frequente combinatie

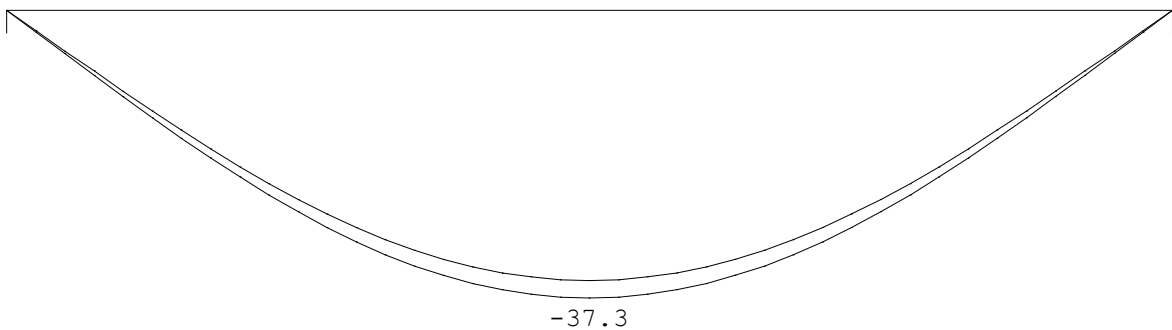

Project.....: 21038 - Herman Gorterstraat

Onderdeel....: Wand as 4

DOORBUIGINGEN Wmax [mm] Ligger:balk dak stramien 4 Frequente combinatie

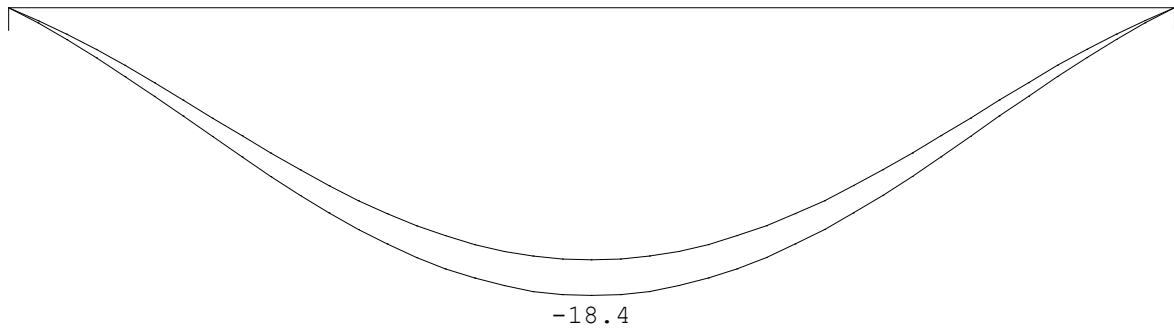

DOORBUIGINGEN Frequente combinatie

Veld	Zijde	positie [m]	l_{rep} [mm]	w_1 [mm]	w_2 [mm]	w_{bij} [mm]	w_{tot} [mm]	w_c [mm]	w_{max} [mm]
1	Neg.	4.720	9440	-24.2	-11.2	-13.2	716	-37.3	18.9

DOORBUIGINGEN Wbij [mm] Ligger:balk dak stramien 4 Quasi-blijvende combinatie

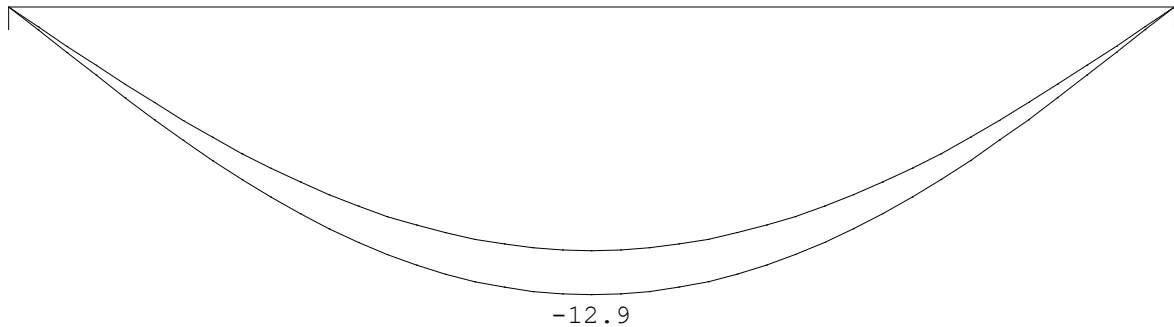

DOORBUIGINGEN Wtot [mm] Ligger:balk dak stramien 4 Quasi-blijvende combinatie

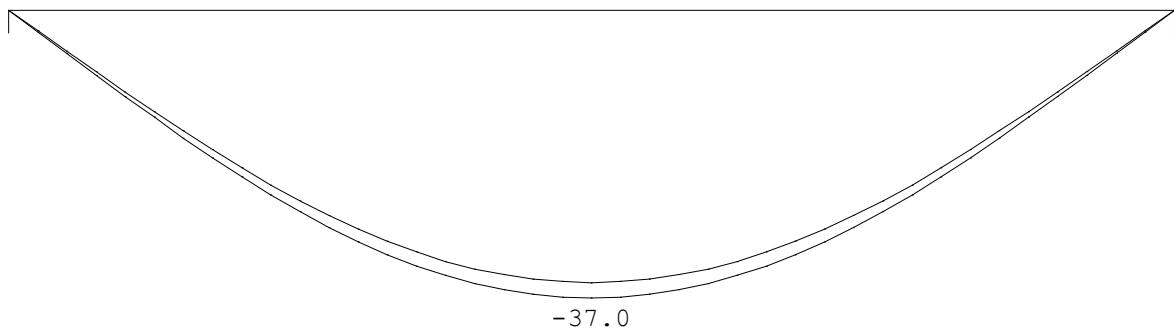

Project.....: 21038 - Herman Gorterstraat

Onderdeel....: Wand as 4

DOORBUIGINGEN Wmax [mm] Ligger:balk dak stramien 4 Quasi-blijvende combinatie

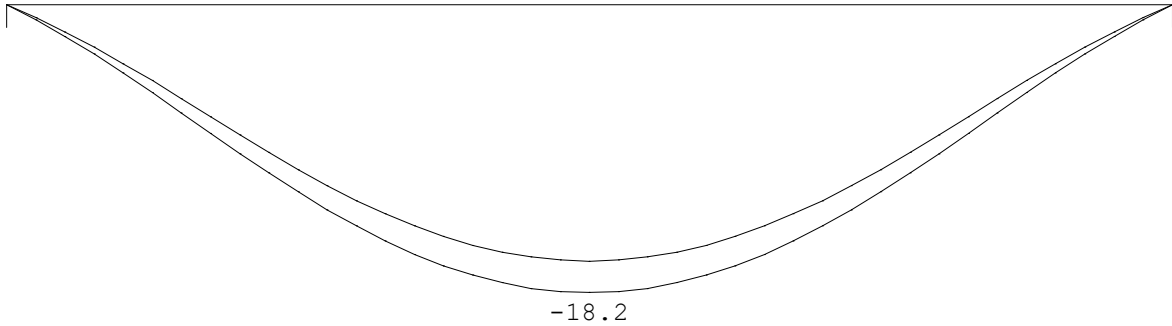

DOORBUIGINGEN

Quasi-blijvende combinatie

Veld	Zijde	positie [m]	l_{rep} [mm]	w_1 [mm]	w_2 [mm]	-- w_{bij} -- [mm] [lrep/]	w_{tot} [mm]	w_c [mm]	-- w_{max} -- [mm] [lrep/]	
1	Neg.	4.720	9440	-24.2	-11.2	-12.9	732	-37.0	18.9 -18.2	520

ZEEG wc [mm]

Ligger:balk dak stramien 4

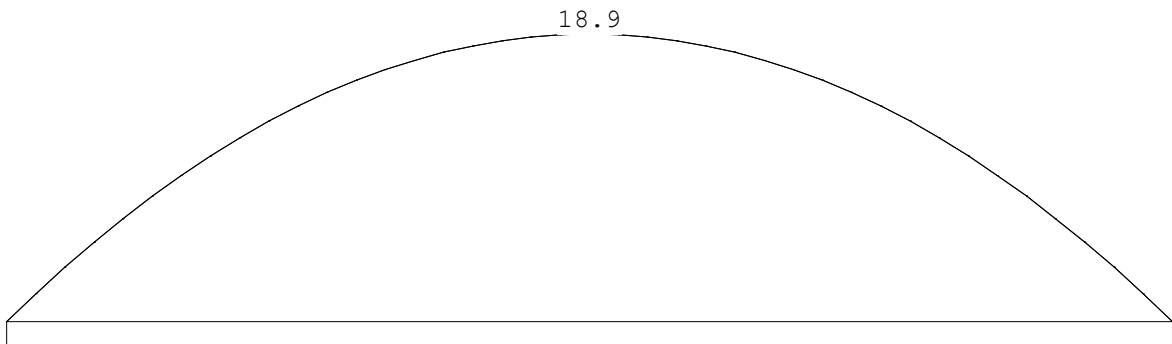

5.9

BIJLAGE 9 – WAND AS 2, 1^E VERD. EN DAK, TUSSEN AS A-B

BIJ

LA

GE



Technosoft Liggers release 6.76
 Project.....: 21038 - Herman Gorterstraat
 Onderdeel....: Wand as 2
 Constructeur.: ing. 5.1, 2, e
 Dimensies....: kN/m ra
 Datum.....: 17/05/2023

17 mei 2023

Betrouwbaarheidsklasse : 2 Referentieperiode : 50
 Herverdelen van momenten : nee Maximale deellengte : 0.000
 Ouderdom bij belasten : 28 Relatieve vochtigheid : 50%
 Doorbuigingen (beton) zijn dmv gecorrigeerde stijfheden berekend.

Fysisch lineair : Er is gerekend met de e-modulus uit de materiaaltabel.
 Fys.NLE.kort : Er is gerekend met een gecorrigeerde e-modulus (korte duur).
 Deze e-mod. is berekend mbv de krachten uit de fysisch lineair berekening.

Toegepaste normen volgens Eurocode met Nederlandse NB

Belastingen	NEN-EN 1990:2002	C2:2010,A1:2019	NB:2019 (nl)
	NEN-EN 1991-1-1:2002	C1/C11:2019	NB:2019 (nl)
Beton	NEN-EN 1992-1-1:2011 (nl)	C2/A1:2015 (nl)	NB:2016 (nl)



Toevallige inklemmingen begin : 15% Toevallige inklemming eind : 15%
 Toevallige inklemmingen : 15% op tussensteunpunten met een scharnier.

GEOMETRIE

Ligger:1

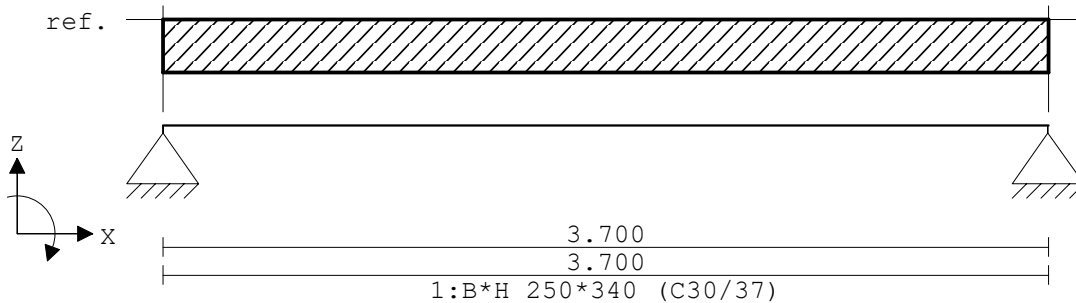

VELDLENGTEN

Ligger:1

Veld	Vanaf	Tot	Lengte
1	0.000	3.700	3.700

MATERIALEN

Mt	Kwaliteit	E-modulus[N/mm2]	S.G.	Pois.	Uitz. coëff
1	C30/37	9465	25.0	0.20	1.0000e-05

Project.....: 21038 - Herman Gorterstraat

Onderdeel....: Wand as 2

MATERIALEN vervolg

Mt	Kwaliteit	Cement	Kruipfac.
1	C30/37	N	2.47

PROFIELEN [mm]

Prof.	Omschrijving	Materiaal	Oppervlak	Traagheid	Vormf.
1	B*H 250*340	1:C30/37	8.5000e+04	8.1883e+08	0.00

PROFIELEN vervolg [mm]

Prof.	Staaftype	Breedte	Hoogte	e	Type	b1	h1	b2	h2
1	0:Normaal	250	340	170.0	0:RH				

PROFIELVORMEN [mm]

1 B*H 250*340



BELASTINGGEVALLEN

B.G.	Omschrijving	Belast/onbelast	ψ_0	ψ_1	ψ_2	e.g.
1	Permanent	2:Permanent EN1991				-1.00
2	Veranderlijk	1:Schaakbord EN1991	0.40	0.70	0.60	0.00

BELASTINGGEVALLEN

B.G.	Omschrijving	Type
1	Permanent	1 Permanente belasting
2	Veranderlijk	2 Ver. bel. pers. ed. (q_k)

VELDBELASTINGEN

Ligger:1 B.G:1 Permanent

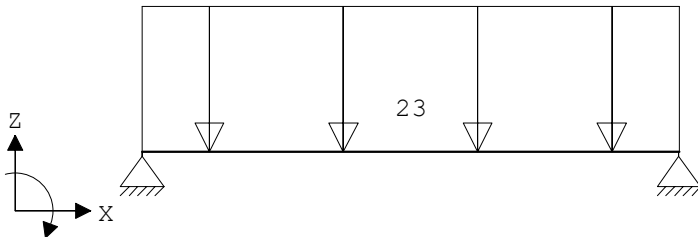

Project.....: 21038 - Herman Gorterstraat

Onderdeel....: Wand as 2

VELDBELASTINGEN

Ligger:1 B.G:1 Permanent

Last Ref.	Type	Omschrijving	q1/p/m	q2	psi	Afstand	Lengte
1	1:q-last		-23.000	-23.000		0.000	3.700

VELDBELASTINGEN

Ligger:1 B.G:2 Veranderlijk

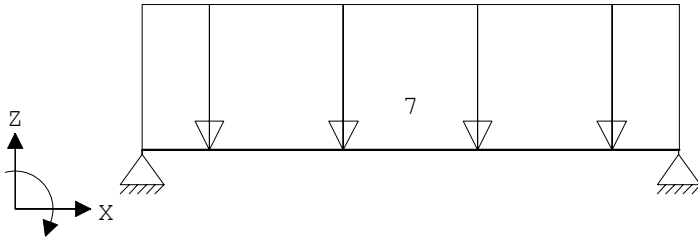

VELDBELASTINGEN

Ligger:1 B.G:2 Veranderlijk

Last Ref.	Type	Omschrijving	q1/p/m	q2	psi	Afstand	Lengte
1	1:q-last		-7.000	-7.000		0.000	3.700

BELASTINGCOMBINATIES

BC	Type	BG	Gen.	Factor	BG	Gen.	Factor	BG	Gen.	Factor	BG	Gen.	Factor
1	Fund.	1	Perm	1.35									
2	Fund.	1	Perm	1.35	2	psi0	1.50						
3	Fund.	1	Perm	1.20	2	Extr	1.50						
4	Fund.	1	Perm	0.90									
5	Fund.	1	Perm	0.90	2	psi0	1.50						
6	Fund.	1	Perm	0.90	2	Extr	1.50						
7	Kar.	1	Perm	1.00	2	Extr	1.00						
8	Freq.	1	Perm	1.00									
9	Freq.	1	Perm	1.00	2	psi1	1.00						
10	Quas.	1	Perm	1.00									
11	Quas.	1	Perm	1.00	2	psi2	1.00						
12	Blij.	1	Perm	1.00									

GUNSTIGE WERKING PERMANENTE BELASTINGEN

BC	Velden met gunstige werking
1	Geen
2	Geen
3	Geen
4	Alle velden de factor:0.90
5	Alle velden de factor:0.90
6	Alle velden de factor:0.90

Project.....: 21038 - Herman Gorterstraat

Onderdeel....: Wand as 2

OMHULLENDE VAN DE FUNDAMENTELE COMBINATIES

MOMENTEN Fysisch lineair

Ligger:1 Fundamentele combinatie

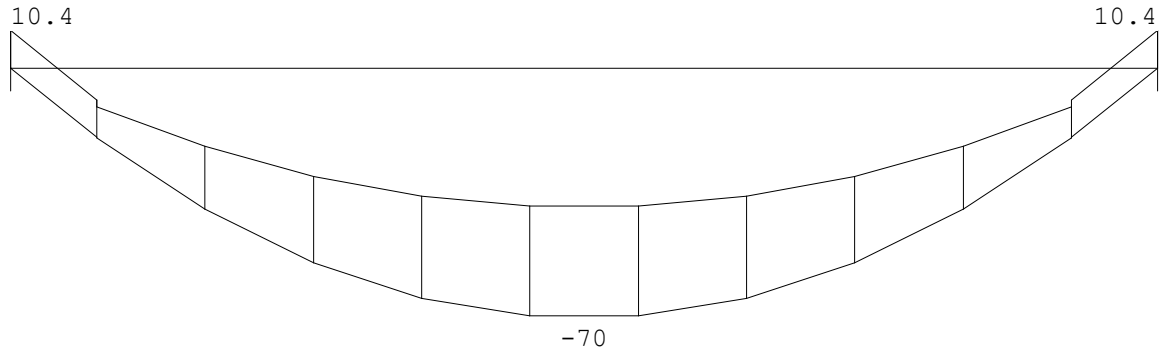

DWARSKRACHTEN Fysisch lineair

Ligger:1 Fundamentele combinatie

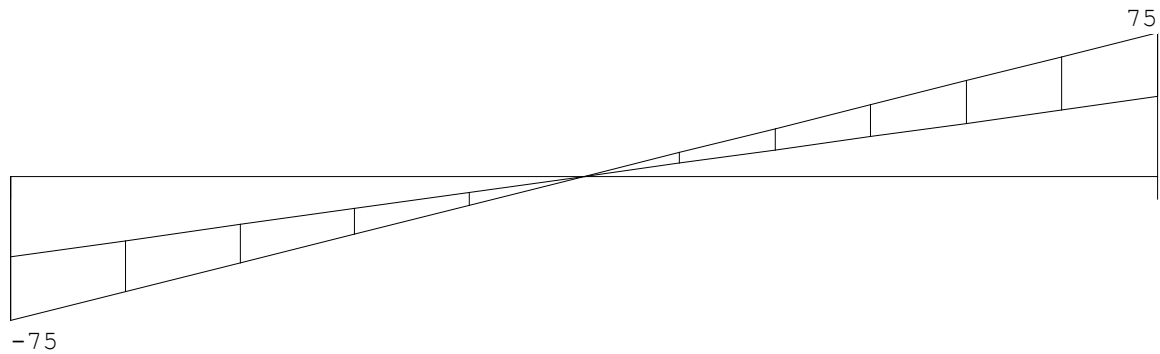

Fmin:41.8
Fmax:75

41.8
75

REACTIES Fysisch lineair

Ligger:1 Fundamentele combinatie

Stp	Fmin	Fmax	Mmin	Mmax
1	41.83	75.20	0.00	0.00
2	41.83	75.20	0.00	0.00

Project.....: 21038 - Herman Gorterstraat

Onderdeel....: Wand as 2

Hoofdwapening Fysisch lineair

Ligger:1 Fundamentele combinatie

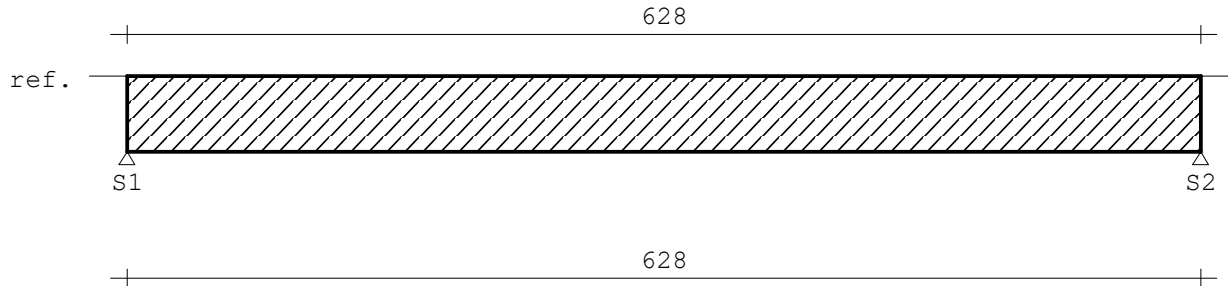

MEd dekkingslijn Fysisch lineair

Ligger:1 Fundamentele combinatie

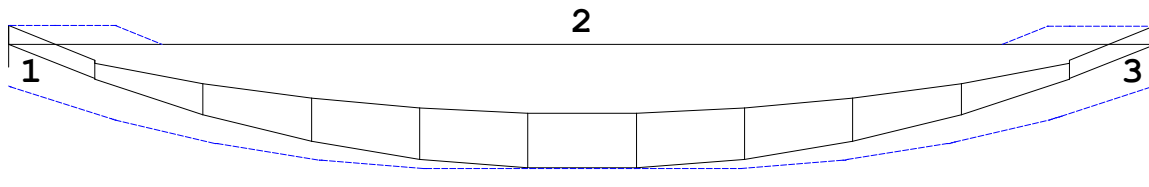

Hoofdwapening

Ligger:1

Geb.	Vanaf [mm]	Tot [mm]	M_{Ed} [kNm]	M_{Rd} [kNm]	z B/O [mm]	A_b [mm ²]	A_a [mm ²]	Opm.	
1	S1+0	S1+144	10.43	80.09	281	Bov	99*	629	54
1	S1+0	S1+144	10.43	80.09	281	Ond	0	628	
2	S1+0	S2+0	-69.56	-80.09	281	Bov	0	628	
2	S1+0	S2+0	-69.56	-80.09	281	Ond	541	629	
3	S2-144	S2+0	10.43	80.09	281	Bov	99*	629	54
3	S2-144	S2+0	10.43	80.09	281	Ond	0	628	

Opmerkingen

Alle maten zijn zonder verschuiving van de m-lijn en verankering

[54] * = Eisen met betrekking tot minimum wapening ten behoeve van gecontroleerde scheurvorming zijn toegepast volgens art. 7.3.2.

Scheurvorming volgens artikel 7.3.4

Ligger:1

Geb.	Pos. [mm]	Zijde	$M_E; freq$ [kNm]	$s_{r, max}$ [mm]	$\epsilon_{sm} - \epsilon_{cm}$ [%]	w_k [mm]	k_x	w_{max} [mm]	U.C.	Opm.
2	S1+1850	Ond	-51.38	164	1.234	0.203	1.33	0.533	0.38	

Project.....: 21038 - Herman Gorterstraat

Onderdeel....: Wand as 2

Dwarskrachtwapening

Ligger:1

Geb.	Vanaf [mm]	Tot [mm]	Beugels	Lengte [mm]	A_{sw} [mm ² /m]	V_{Ed} [kN]	A_{opg} [mm ²]	Opm.
1	S1+0	S1+800	Ø8-150	800	245	75		6
2	S1+800	S2-800	Ø8-300	2100	219	43		
3	S2-800	S2+0	Ø8-150	800	245	75		6

Opmerkingen

[6] 9.2.2 (4) 50% van de dwarskrachtwapening moet uit beugels bestaan.

Schuifspanningen

Ligger:1

Geb.	Vanaf [mm]	Tot [mm]	θ [°]	V_{Ed} [kN]	$V_{Rd,C}$	$V_{Rd,S}$	$V_{Ed} < V_{Rd} < V_{Rd,Max}$ [N/mm ²]	Opm.
1	S1+0	S1+800	21.8	75.08	0.63	2.68	0.98 2.68	3.35 6
2	S1+800	S2-800	21.8	42.56	0.63	1.34	0.56 1.34	3.35
3	S2-800	S2+0	21.8	75.08	0.63	2.68	0.98 2.68	3.35 6

Opmerkingen

[6] 9.2.2 (4) 50% van de dwarskrachtwapening moet uit beugels bestaan.

Toetsing doorbuiging

Veld	Mtg	Lengte [m]	Type	wtot [mm]	Zeeg [mm]	w [mm]	--Toel.1-- [mm]	Toel.2 u.c. *L [mm]
1	db	3.70	Quasi-Blijvend Eind	-10.2	0	-10.2	14.8	0.004 20.0 0.69
	db		Frequent Bijk			-4.7	7.4	0.002 15.0 0.64

DOORBUIGINGEN w1 [mm]

Ligger:1 Blijvende combinatie

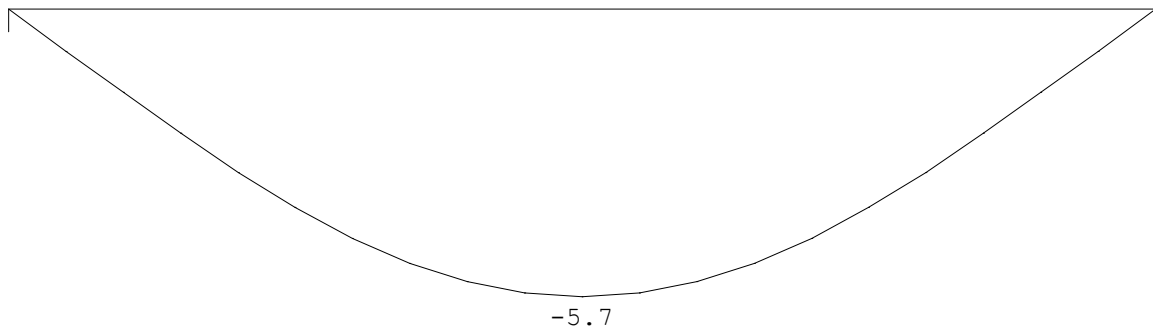

Project.....: 21038 - Herman Gorterstraat

Onderdeel....: Wand as 2

DOORBUIGINGEN w_2 [mm]

Ligger:1 Quasi-blijvende combinatie

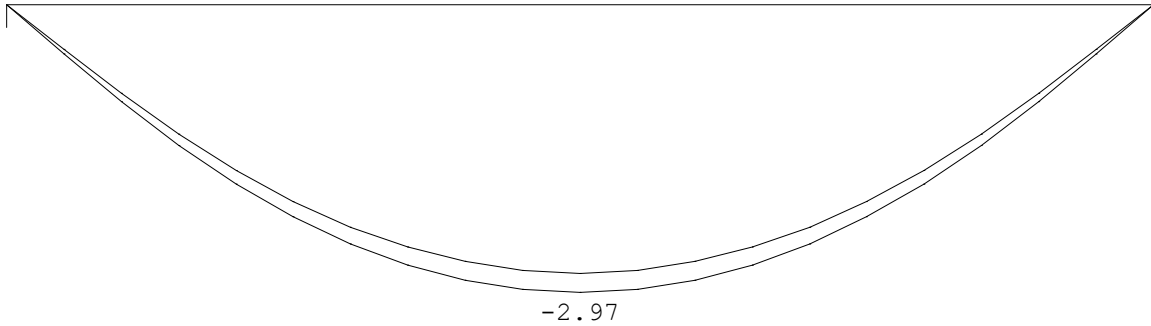

DOORBUIGINGEN w_{bij} [mm]

Ligger:1 Karakteristieke combinatie

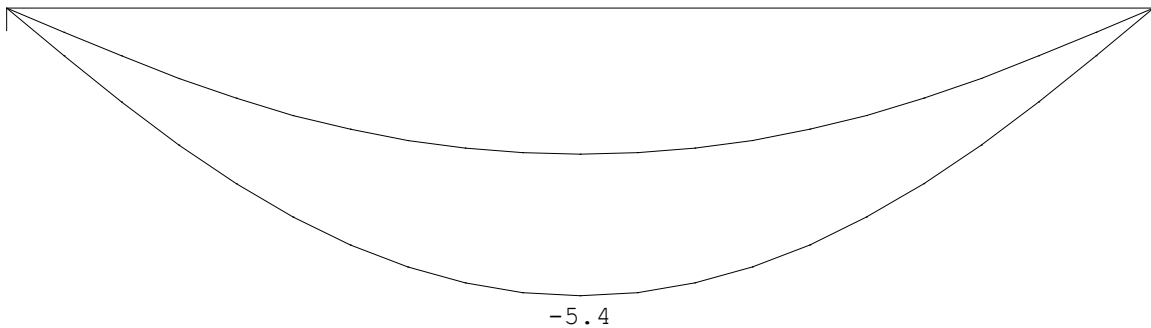

DOORBUIGINGEN w_{max} [mm]

Ligger:1 Karakteristieke combinatie

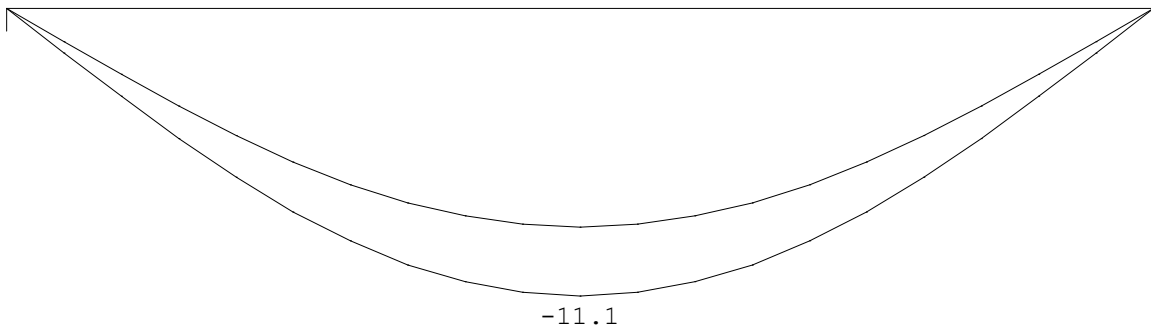

DOORBUIGINGEN

Karakteristieke combinatie

Veld	Zijde	positie	l_{rep}	w_1	w_2	w_{bij}	w_{tot}	w_c	w_{max}
		[m]	[mm]	[mm]	[mm]	[mm]	[mm]	[mm]	[mm]
						[lrep/]			[lrep/]

Project.....: 21038 - Herman Gorterstraat

Onderdeel....: Wand as 2

DOORBUIGINGEN

Karakteristieke combinatie

Veld	Zijde	positie	l_{rep}	w_1	w_2	-- w_{bij} --	w_{tot}	w_c	-- w_{max} --	
		[m]	[mm]	[mm]	[mm]	[mm][lrep/]	[mm]	[mm]	[mm][lrep/]	
1	Neg.	1.850	3700	-5.7	-3.0	-5.4	681	-11.1	-11.1	332

DOORBUIGINGEN w_{bij} [mm]

Ligger:1 Frequente combinatie

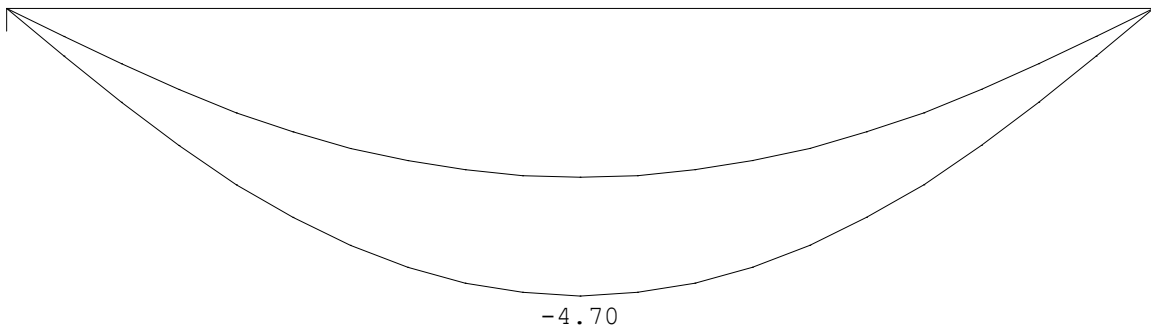

DOORBUIGINGEN w_{max} [mm]

Ligger:1 Frequente combinatie

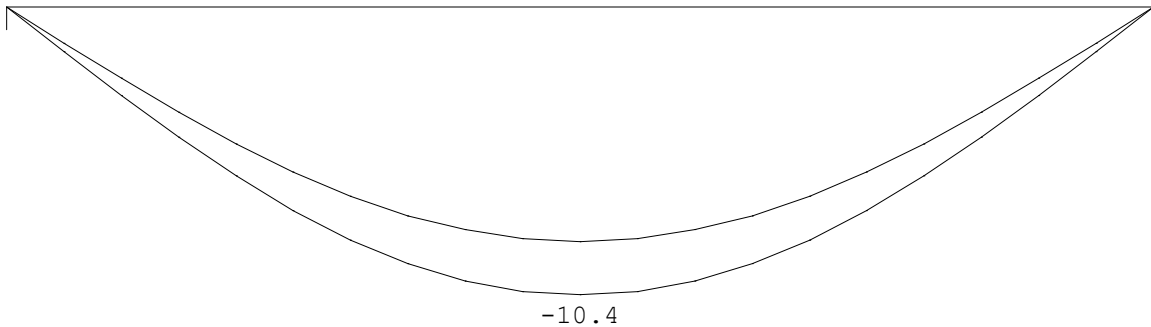

DOORBUIGINGEN

Frequente combinatie

Veld	Zijde	positie	l_{rep}	w_1	w_2	-- w_{bij} --	w_{tot}	w_c	-- w_{max} --	
		[m]	[mm]	[mm]	[mm]	[mm][lrep/]	[mm]	[mm]	[mm][lrep/]	
1	Neg.	1.850	3700	-5.7	-3.0	-4.7	787	-10.4	-10.4	355

Project.....: 21038 - Herman Gorterstraat

Onderdeel....: Wand as 2

DOORBUIGINGEN w_{bij} [mm]

Ligger:1 Quasi-blijvende combinatie

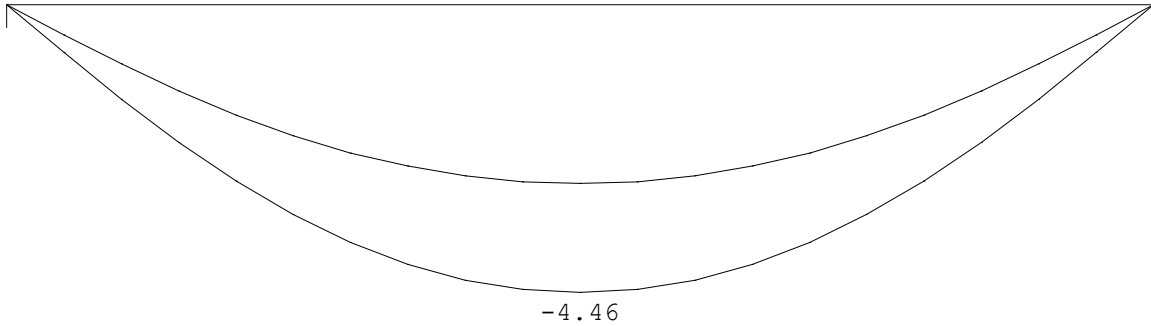

DOORBUIGINGEN w_{max} [mm]

Ligger:1 Quasi-blijvende combinatie

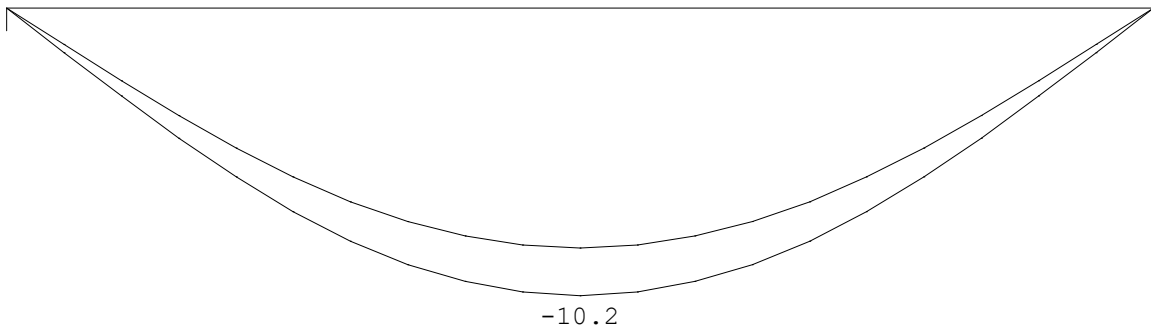

DOORBUIGINGEN

Quasi-blijvende combinatie

Veld	Zijde	positie	l_{rep}	w_1	w_2	w_{bij}	w_{tot}	w_c	w_{max}	
		[m]	[mm]	[mm]	[mm]	[mm][lrep/]	[mm]	[mm]	[mm][lrep/]	
1	Neg.	1.850	3700	-5.7	-3.0	-4.5	830	-10.2	-10.2	364

5.10

BIJLAGE 10 – WAND AS 2, 1^E VERD. EN DAK, TUSSEN AS B-D

BIJ

LA

GE



Technosoft Liggers release 6.76 17 mei 2023
 Project.....: 21038 - Herman Gorterstraat
 Onderdeel....: Wand as 2
 Constructeur.: ing **5.1, 2, e**
 Dimensies....: kN/m/rad
 Datum.....: 17/05/2023
 Bestand.....: J:\Dropbox (BREEDID)\Projecten 2021\21038 - Herman
 Gorterstraat\BREED ID\Calculations\5_Werkfase\wapening
 wanden + keldervloer\20230517_Wand as 2.dlw

Betrouwbaarheidsklasse : 2 Referentieperiode : 50
 Herverdelen van momenten : nee Maximale deellengte : 0.000
 Ouderdom bij belasten : 28 Relatieve vochtigheid : 50%
 Doorbuigingen(beton) zijn dmv gecorrigeerde stijfheden berekend.

Fysisch lineair : Er is gerekend met de e-modulus uit de materiaaltabel.
 Fys.NLE.kort : Er is gerekend met een gecorrigeerde e-modulus (korte duur).
 Deze e-mod. is berekend mbv de krachten uit de fysisch lineair berekening.

Toegepaste normen volgens Eurocode met Nederlandse NB

Belastingen	NEN-EN 1990:2002	C2:2010,A1:2019	NB:2019(nl)
	NEN-EN 1991-1-1:2002	C1/C11:2019	NB:2019(nl)
Beton	NEN-EN 1992-1-1:2011(nl)	C2/A1:2015(nl)	NB:2016(nl)



LIGGER:2

Toevallige inklemmingen begin : geen Toevallige inklemming eind : 15%
 Toevallige inklemmingen : 15% op tussensteunpunten met een scharnier.

GEOMETRIE

Ligger:2

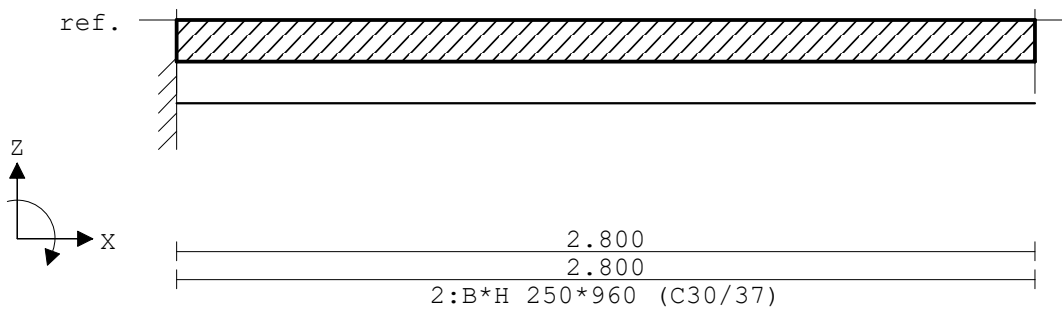

VELDLONGTEN

Ligger:2

Veld	Vanaf	Tot	Lengte
1	0.000	2.800	2.800

Project.....: 21038 - Herman Gorterstraat

Onderdeel....: Wand as 2

MATERIALEN

Mt	Kwaliteit	E-modulus[N/mm2]	S.G.	Pois.	Uitz. coëff
1	C30/37	9465	25.0	0.20	1.0000e-05

MATERIALEN vervolg

Mt	Kwaliteit	Cement	Kruipfac.
1	C30/37	N	2.47

PROFIELEN [mm]

Prof.	Omschrijving	Materiaal	Oppervlak	Traagheid	Vormf.
1	B*H 250*340	1:C30/37	8.5000e+04	8.1883e+08	0.00
2	B*H 250*960	1:C30/37	2.4000e+05	1.8432e+10	0.00
3	B*H 250*600	1:C30/37	1.5000e+05	4.5000e+09	0.00

PROFIELEN vervolg [mm]

Prof.	Staaftype	Breedte	Hoogte	e	Type	b1	h1	b2	h2
1	0:Normaal	250	340	170.0	0:RH				
2	0:Normaal	250	960	480.0	0:RH				
3	0:Normaal	250	600	300.0	0:RH				

DOORSNEDEN

Ligger:2

sector	Vanaf	Tot	Lengte	Profiel begin	z-begin	Profiel eind	z-eind
1	0.000	2.800	2.800	2:B*H 250*960	0.000	2:B*H 250*960	0.000

sector	Vanaf	Tot	Lengte	Eindcode	Bedding Br.[mm]
1	0.000	2.800	2.800	1:Vast	

PROFIELVORMEN [mm]

1 B*H 250*340



2 B*H 250*960



3 B*H 250*600



Project.....: 21038 - Herman Gorterstraat

Onderdeel....: Wand as 2

BELASTINGGEVALLEN

B.G.	Omschrijving	Belast/onbelast	Ψ_0	Ψ_1	Ψ_2	e.g.
1	Permanent	2:Permanent EN1991				-1.00
2	Veranderlijk	1:Schaakbord EN1991	0.40	0.70	0.60	0.00

BELASTINGGEVALLEN

B.G.	Omschrijving	Type
1	Permanent	1 Permanente belasting
2	Veranderlijk	2 Ver. bel. pers. ed. (q_k)

VELDBELASTINGEN

Ligger:2 B.G:1 Permanent

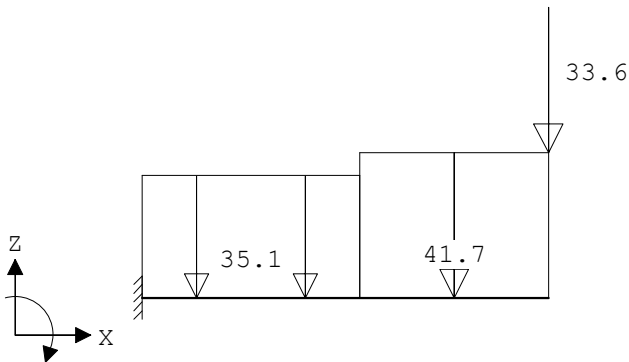

VELDBELASTINGEN

Ligger:2 B.G:1 Permanent

Last Ref.	Type	Omschrijving	q1/p/m	q2	psi	Afstand	Lengte
1	1:q-last		-35.100	-35.100		0.000	1.500
2	8:Puntlast			-33.600		2.800	
3	1:q-last		-41.700	-41.700		1.500	1.300

VELDBELASTINGEN

Ligger:2 B.G:2 Veranderlijk

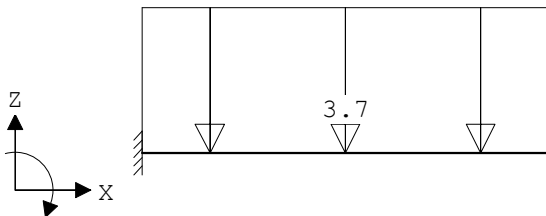

Project.....: 21038 - Herman Gorterstraat
 Onderdeel....: Wand as 2

VELDBELASTINGEN

Ligger:2 B.G:2 Veranderlijk

Last Ref.	Type	Omschrijving	q1/p/m	q2	psi	Afstand	Lengte
1	1:q-last		-3.700	-3.700		0.000	2.800

BELASTINGCOMBINATIES

BC Type	BG Gen.	Factor	BG Gen.	Factor	BG Gen.	Factor	BG Gen.	Factor
1 Fund.	1 Perm	1.35						
2 Fund.	1 Perm	1.35	2 psi0	1.50				
3 Fund.	1 Perm	1.20	2 Extr	1.50				
4 Fund.	1 Perm	0.90						
5 Fund.	1 Perm	0.90	2 psi0	1.50				
6 Fund.	1 Perm	0.90	2 Extr	1.50				
7 Kar.	1 Perm	1.00	2 Extr	1.00				
8 Freq.	1 Perm	1.00						
9 Freq.	1 Perm	1.00	2 psi1	1.00				
10 Quas.	1 Perm	1.00						
11 Quas.	1 Perm	1.00	2 psi2	1.00				
12 Blij.	1 Perm	1.00						

GUNSTIGE WERKING PERMANENTE BELASTINGEN

BC Velden met gunstige werking

- 1 Geen
- 2 Geen
- 3 Geen
- 4 Alle velden de factor:0.90
- 5 Alle velden de factor:0.90
- 6 Alle velden de factor:0.90

OMHULLENDE VAN DE FUNDAMENTELE COMBINATIES

MOMENTEN Fysisch lineair

Ligger:2 Fundamentele combinatie

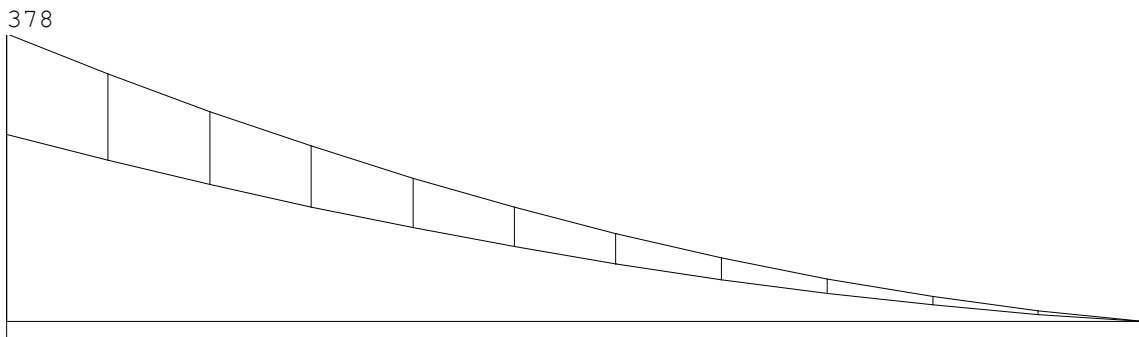

Project.....: 21038 - Herman Gorterstraat

Onderdeel....: Wand as 2

DWARSKRACHTEN Fysisch lineair

Ligger:2 Fundamentele combinatie

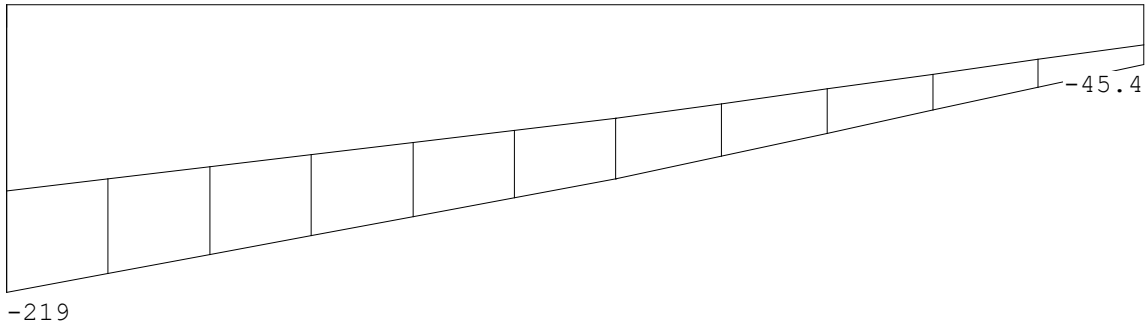

Fmin:142
Fmax:219

REACTIES Fysisch lineair

Ligger:2 Fundamentele combinatie

Stp	Fmin	Fmax	Mmin	Mmax
1	141.53	218.52	-378.12	-246.28

Hoofdwapening Fysisch lineair

Ligger:2 Fundamentele combinatie

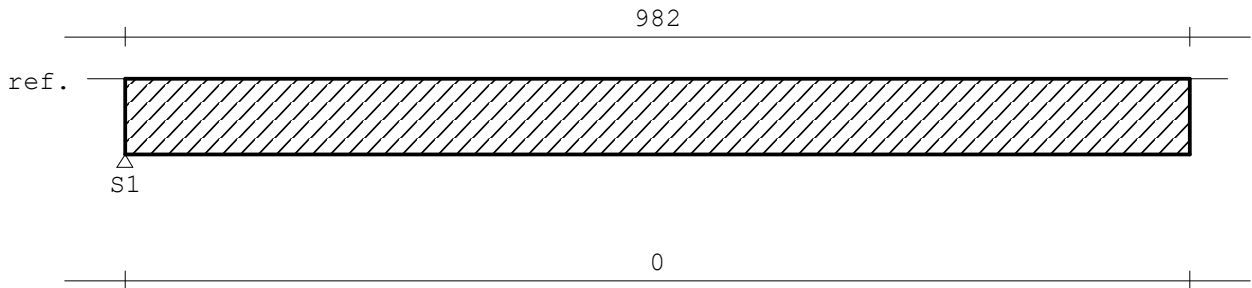

MEd dekkingslijn Fysisch lineair

Ligger:2 Fundamentele combinatie

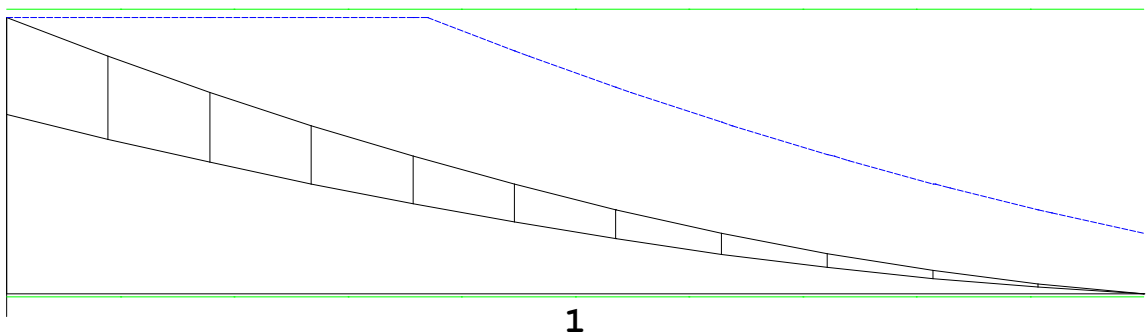

Project.....: 21038 - Herman Gorterstraat

Onderdeel....: Wand as 2

Hoofdwapening

Ligger:2

Geb.	Vanaf [mm]	Tot [mm]	M_{Ed} [kNm]	M_{Rd} [kNm]	z B/O [mm]	A_b [mm ²]	A_a [mm ²]	Opm.	
1	S1+0	S1+2800	378.12	390.03	874	Bov	951	982	2,68

Opmerkingen

[2] Benodigde wapening en inwendige hefboomsarm zijn bepaald volgens gedrongen ligger detaillering, zie nationale bijlage art. 6.1(10).

Alle maten zijn zonder verschuiving van de m-lijn en verankering

[68] MRd als gevolg van de gedrongen ligger berekening (NB. 6.1(10)) is groter dan MRd volgens 6.1(P). De momentweerstand en inwendige hefboomsarm volgens 6.1(P) zijn maatgevend en daarom alsnog toegepast.

Scheurvorming volgens artikel 7.3.4

Ligger:2

Geb.	Pos. [mm]	Zijde	$M_{E, freq}$ [kNm]	$s_{r, max}$ [mm]	$\epsilon_{sm} - \epsilon_{cm}$ [%]	w_k [mm]	k_x	w_{max} [mm]	U.C.	Opm.
1	S1+0	Bov	283.79	162	1.504	0.245	1.67	0.667	0.37	

Dwarskrachtwapening

Ligger:2

Geb.	Vanaf [mm]	Tot [mm]	Beugels	Lengte [mm]	A_{sw} [mm ² /m]	V_{Ed} [kN]	A_{opg} [mm ²]	Opm.
1	S1+0	S1+2300	Ø8-300	2300	242	218		6,58
2	S1+2300	S1+2800	Ø8-300	500	219	78		58

Opmerkingen

[6] 9.2.2 (4) 50% van de dwarskrachtwapening moet uit beugels bestaan.

[58] 6.2.3: Z is berekend m.b.v. 0.9d

Schuifspanningen

Ligger:2

Geb.	Vanaf [mm]	Tot [mm]	θ [°]	V_{Ed} [kN]	$v_{Rd, c}$	$v_{Rd, s}$	$v_{Ed} < v_{Rd} < v_{Rd, Max}$ [N/mm ²]	Opm.		
1	S1+0	S1+2300	21.8	218.34	0.41	1.31	0.95	1.31	3.28	6,58
2	S1+2300	S1+2800	21.8	78.47	0.41	1.31	0.34	1.31	3.28	58

Opmerkingen

[6] 9.2.2 (4) 50% van de dwarskrachtwapening moet uit beugels bestaan.

[58] 6.2.3: Z is berekend m.b.v. 0.9d

Toetsing doorbuiging

Veld	Mtg	Lengte [m]	Type	wtot	Zeeg	w	--Toel.1--	Toel.2 u.c.		
				[mm]	[mm]	[mm]	[mm]	*L [mm]		
1	ss	2.80	Quasi-Blijvend Eind	-5.3	0	-5.3	22.4	2*0.004	20.0	0.27
	ss		Frequent Bijk			-2.4	11.2	2*0.002	15.0	0.21

Project.....: 21038 - Herman Gorterstraat

Onderdeel....: Wand as 2

DOORBUIGINGEN w1 [mm]

Ligger:2 Blijvende combinatie

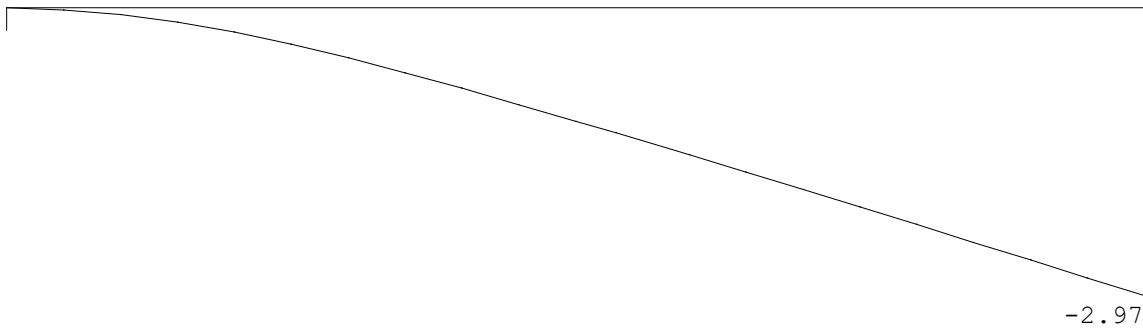

DOORBUIGINGEN w2 [mm]

Ligger:2 Quasi-blijvende combinatie

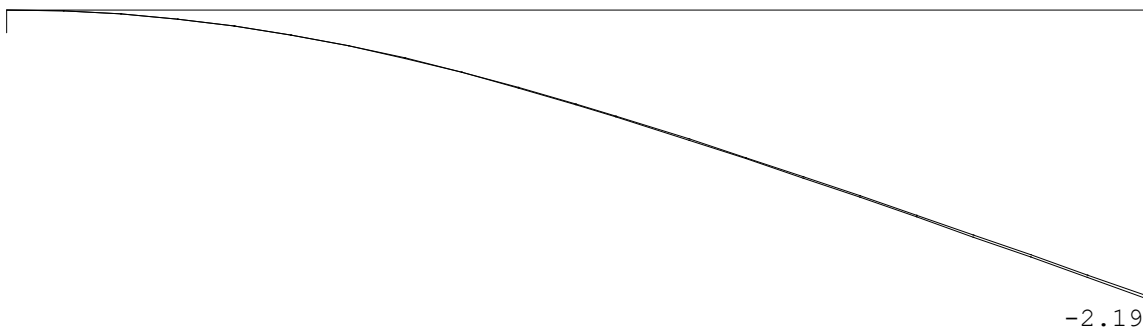

DOORBUIGINGEN wbij [mm]

Ligger:2 Karakteristieke combinatie

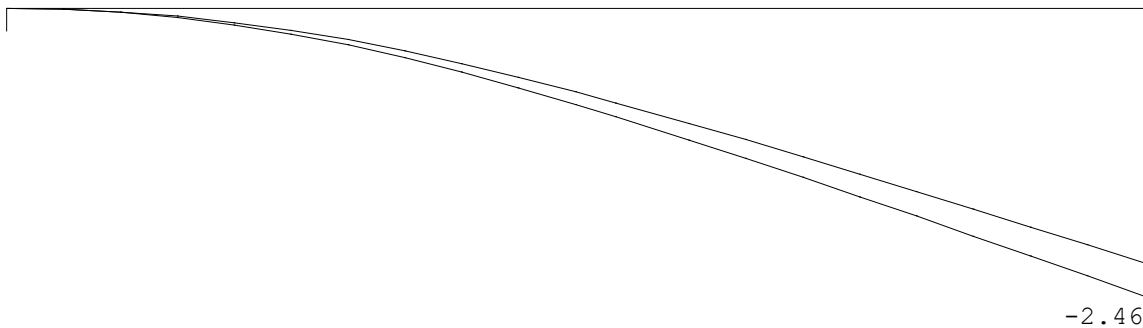

Project.....: 21038 - Herman Gorterstraat

Onderdeel....: Wand as 2

DOORBUIGINGEN Wmax [mm]

Ligger:2 Karakteristieke combinatie

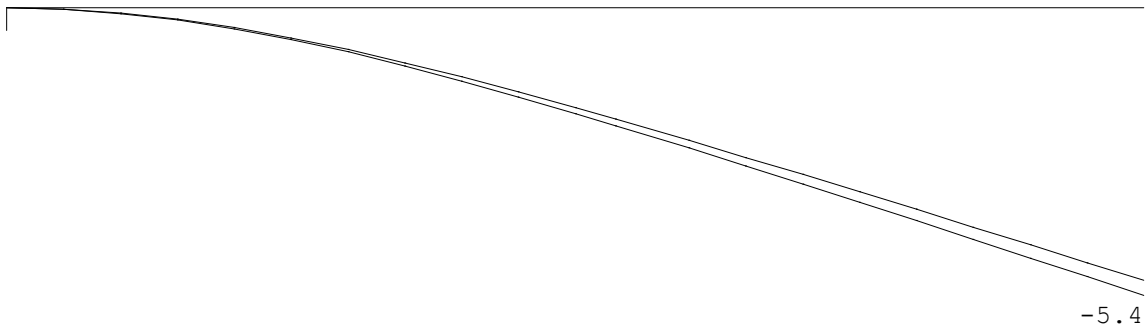

DOORBUIGINGEN

Karakteristieke combinatie

Veld	Zijde	positie	l_{rep}	w_1	w_2	-- w_{bij} --	w_{tot}	w_c	-- w_{max} --	
		[m]	[mm]	[mm]	[mm]	[mm] [lrep/]	[mm]	[mm]	[mm] [lrep/]	
1	Neg.	/	5600	-3.0	-2.2	-2.5	2279	-5.4	-5.4	1032
1	Pos.	1.400	2800	0.3	0.4	0.4	6900	0.7	0.7	3870

DOORBUIGINGEN Wbij [mm]

Ligger:2 Frequente combinatie

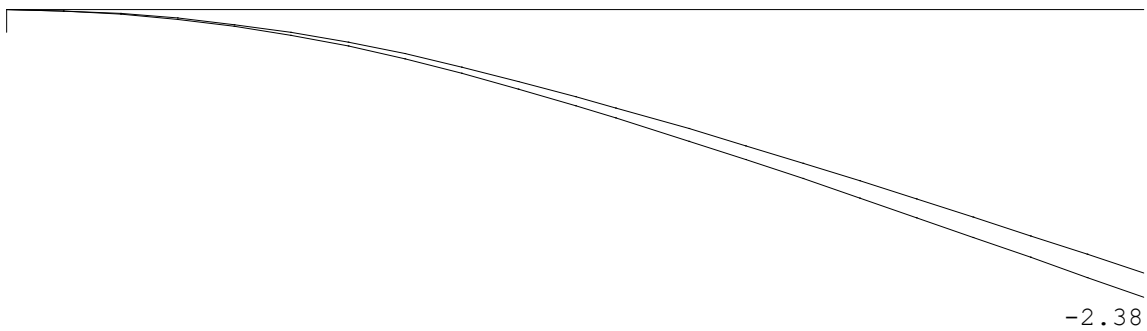

DOORBUIGINGEN Wmax [mm]

Ligger:2 Frequente combinatie

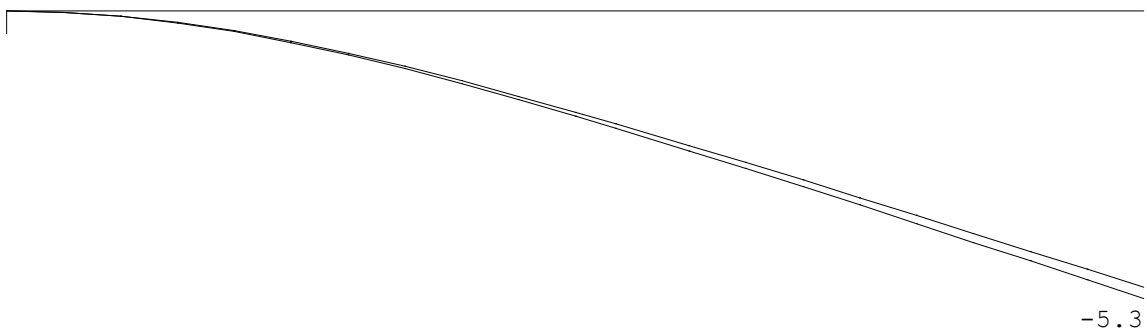

Project.....: 21038 - Herman Gorterstraat

Onderdeel....: Wand as 2

DOORBUIGINGEN

Frequente combinatie

Veld	Zijde	positie	l_{rep}	w_1	w_2	w_{bij}	w_{tot}	w_c	w_{max}
		[m]	[mm]	[mm]	[mm]	[mm][lrep/]	[mm]	[mm]	[mm][lrep/]
1	Neg.	/	5600	-3.0	-2.2	-2.4	2354	-5.3	-5.3 1047
1	Pos.	1.400	2800	0.3	0.4	0.4	7059	0.7	0.7 3920

DOORBUIGINGEN w_{bij}

[mm]

Ligger:2 Quasi-blijvende combinatie

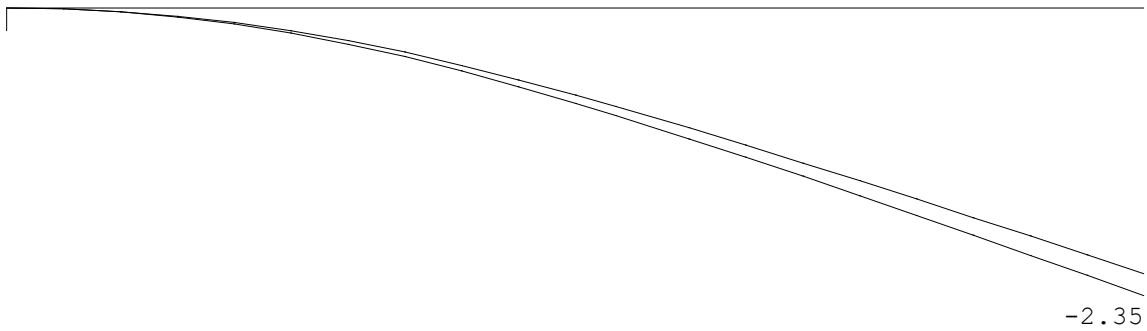

DOORBUIGINGEN w_{max}

[mm]

Ligger:2 Quasi-blijvende combinatie

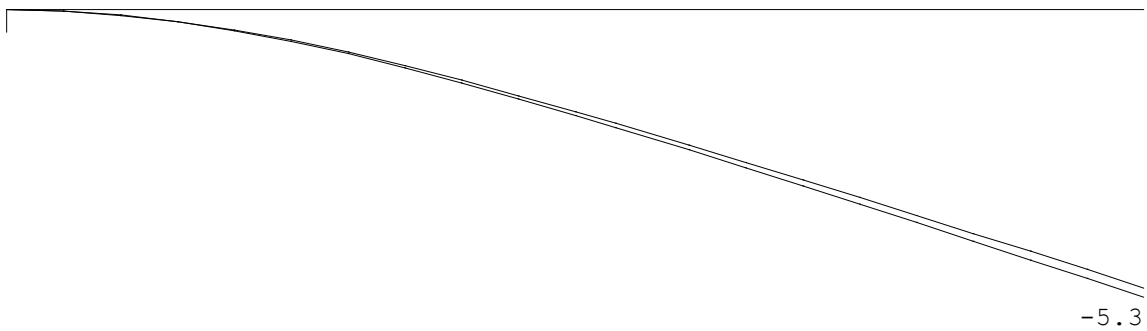

DOORBUIGINGEN

Quasi-blijvende combinatie

Veld	Zijde	positie	l_{rep}	w_1	w_2	w_{bij}	w_{tot}	w_c	w_{max}
		[m]	[mm]	[mm]	[mm]	[mm][lrep/]	[mm]	[mm]	[mm][lrep/]
1	Neg.	/	5600	-3.0	-2.2	-2.4	2380	-5.3	-5.3 1052
1	Pos.	1.400	2800	0.3	0.4	0.4	7114	0.7	0.7 3937

Project.....: 21038 - Herman Gorterstraat
 Onderdeel....: Wand as 2

LIGGER: 3

Toevallige inklemmingen begin : geen Toevallige inklemming eind : 15%
 Toevallige inklemmingen : 15% op tussensteunpunten met een scharnier.

GEOMETRIE

Ligger:3

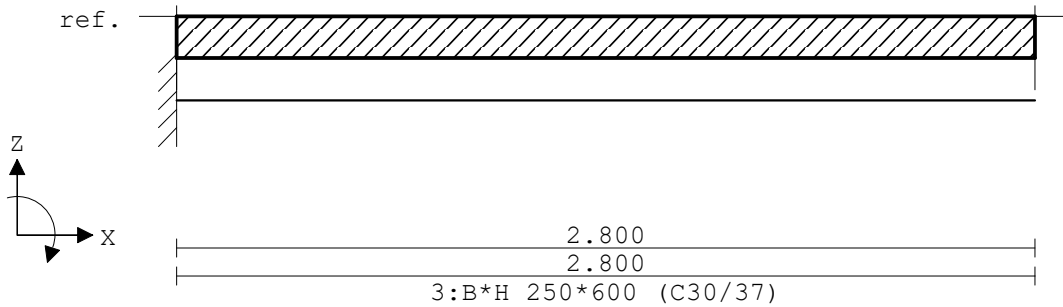

VELDLENGTEN

Ligger:3

Veld	Vanaf	Tot	Lengte
1	0.000	2.800	2.800



DOORSNEDEN

Ligger:3

sector	Vanaf	Tot	Lengte	Profiel begin	z-begin	Profiel eind	z-eind
1	0.000	2.800	2.800	3:B*H 250*600	0.000	3:B*H 250*600	0.000

sector	Vanaf	Tot	Lengte	Eindcode	Bedding	Br. [mm]
1	0.000	2.800	2.800	1:Vast		

PROFIELVORMEN [mm]

- 1 B*H 250*340 
- 2 B*H 250*960 
- 3 B*H 250*600 

Project.....: 21038 - Herman Gorterstraat

Onderdeel....: Wand as 2

VELDBELASTINGEN

Ligger:3 B.G:1 Permanent

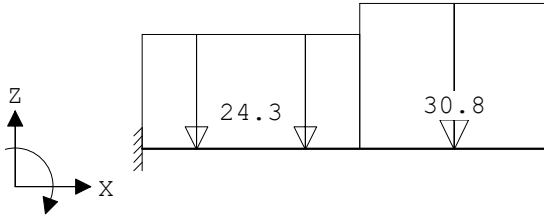

VELDBELASTINGEN

Ligger:3 B.G:1 Permanent

Last Ref.	Type	Omschrijving	q1/p/m	q2	psi	Afstand	Lengte
1	1:q-last		-24.300	-24.300		0.000	1.500
2	1:q-last		-30.800	-30.800		1.500	1.300

VELDBELASTINGEN

Ligger:3 B.G:2 Veranderlijk

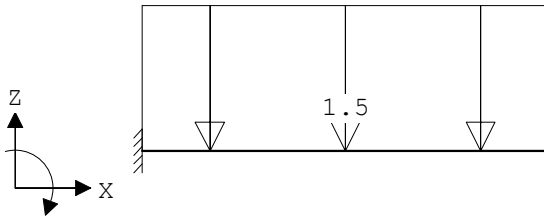

VELDBELASTINGEN

Ligger:3 B.G:2 Veranderlijk

Last Ref.	Type	Omschrijving	q1/p/m	q2	psi	Afstand	Lengte
1	1:q-last		-1.500	-1.500		0.000	2.800

OMHULLENDE VAN DE FUNDAMENTELE COMBINATIES

MOMENTEN Fysisch lineair

Ligger:3 Fundamentele combinatie

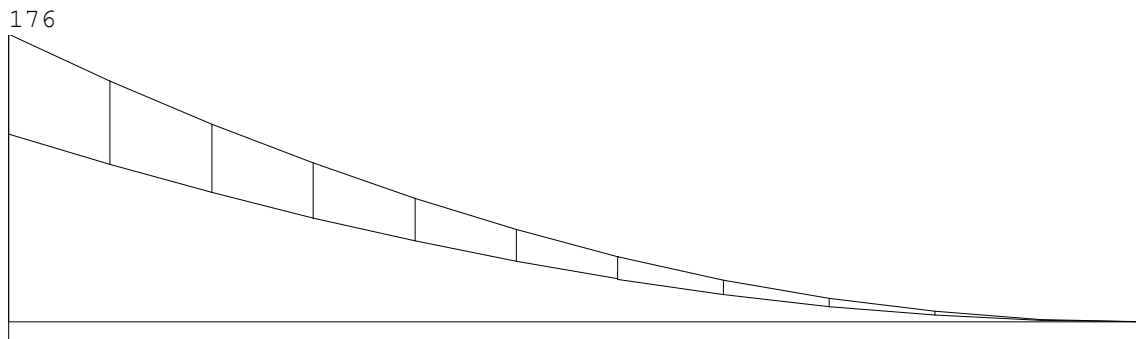

Project.....: 21038 - Herman Gorterstraat

Onderdeel....: Wand as 2

DWARSKRACHTEN Fysisch lineair

Ligger:3 Fundamentele combinatie

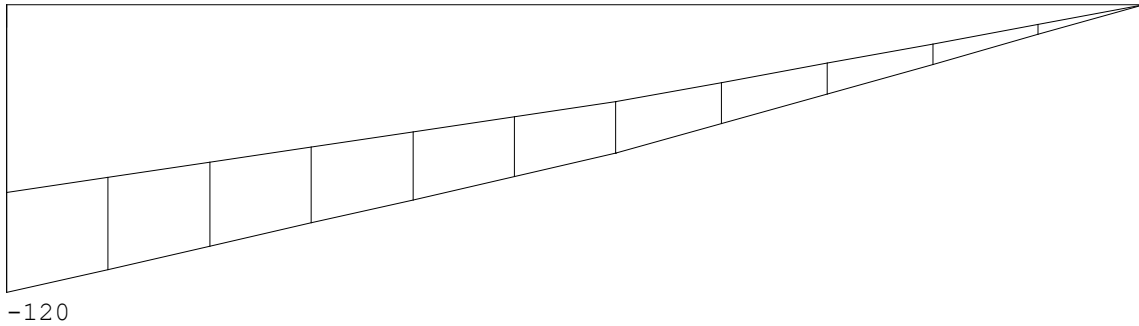

Fmin:78
Fmax:120

REACTIES Fysisch lineair

Ligger:3 Fundamentele combinatie

Stp	Fmin	Fmax	Mmin	Mmax
1	78.29	119.96	-176.49	-115.31

Hoofdwapening Fysisch lineair

Ligger:3 Fundamentele combinatie

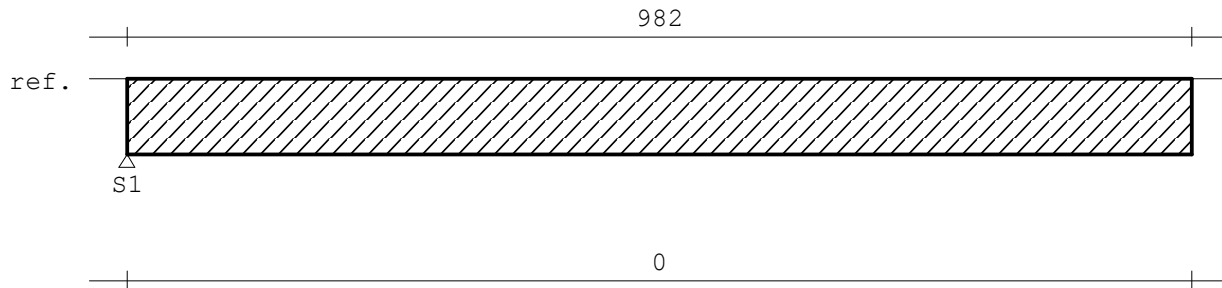

MEd dekkingslijn Fysisch lineair

Ligger:3 Fundamentele combinatie

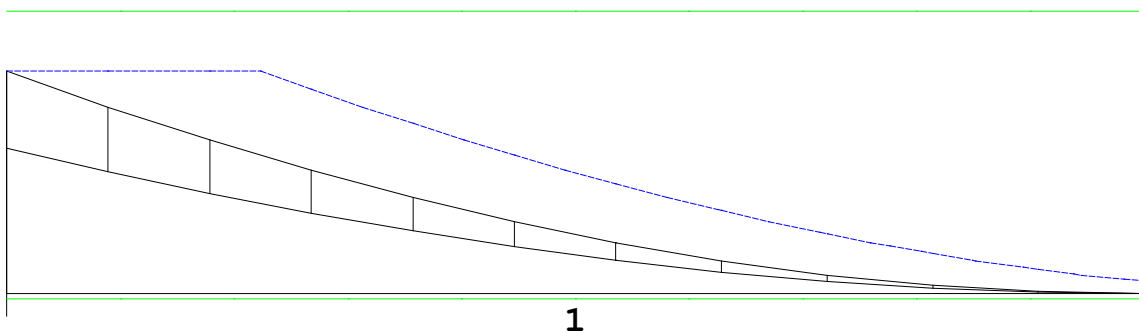

Project.....: 21038 - Herman Gorterstraat

Onderdeel....: Wand as 2

Hoofdwapening

Ligger:3

Geb.	Vanaf [mm]	Tot [mm]	M_{Ed} [kNm]	M_{Rd} [kNm]	z B/O [mm]	A_b [mm ²]	A_a [mm ²]	Opm.
1	S1+0	S1+2800	176.49	223.97	510	Bov	751	982

Opmerkingen

Alle maten zijn zonder verschuiving van de m-lijn en verankering**Scheurvorming volgens artikel 7.3.4**

Ligger:3

Geb.	Pos. [mm]	Zijde	$M_{E;freq}$ [kNm]	$s_{r,max}$ [mm]	$\epsilon_{sm} - \epsilon_{cm}$ [%]	w_k [mm]	k_x	w_{max} [mm]	U.C.	Opm.
1	S1+0	Bov	132.24	186	1.126	0.210	2.00	0.800	0.26	

Dwarskrachtwapening

Ligger:3

Geb.	Vanaf [mm]	Tot [mm]	Beugels	Lengte [mm]	A_{sw} [mm ² /m]	V_{Ed} [kN]	A_{opg} [mm ²]	Opm.
1	S1+0	S1+1400	Ø8-300	1400	219	120		6
2	S1+1400	S1+2800	Ø8-300	1400	219	66		

Opmerkingen

[6] 9.2.2 (4) 50% van de dwarskrachtwapening moet uit beugels bestaan.**Schuifspanningen**

Ligger:3

Geb.	Vanaf [mm]	Tot [mm]	θ [°]	V_{Ed} [kN]	$V_{Rd,c}$	$V_{Rd,s}$	$V_{Ed} < V_{Rd} < V_{Rd,Max}$ [N/mm ²]	Opm.		
1	S1+0	S1+1400	21.8	119.84	0.53	1.34	0.86	1.34	3.35	6
2	S1+1400	S1+2800	21.8	65.57	0.53	1.34	0.47	1.34	3.35	

Opmerkingen

[6] 9.2.2 (4) 50% van de dwarskrachtwapening moet uit beugels bestaan.**Toetsing doorbuiging**

Veld	Mtg	Lengte [m]	Type	wtot [mm]	Zeeg [mm]	w [mm]	---Toel.1--- [mm]	Toel.2 *L [mm]	u.c.	
1	ss	2.80	Quasi-Blijvend Eind	-7.6	0	-7.6	22.4	2*0.004	20.0	0.38
	ss		Frequent Bijk			-3.4	11.2	2*0.002	15.0	0.30

Project.....: 21038 - Herman Gorterstraat

Onderdeel....: Wand as 2

DOORBUIGINGEN w1 [mm]

Ligger:3 Blijvende combinatie

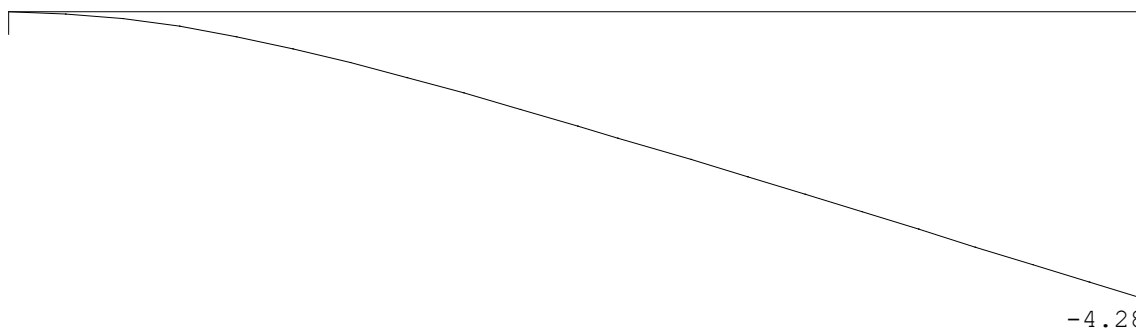

DOORBUIGINGEN w2 [mm]

Ligger:3 Quasi-blijvende combinatie

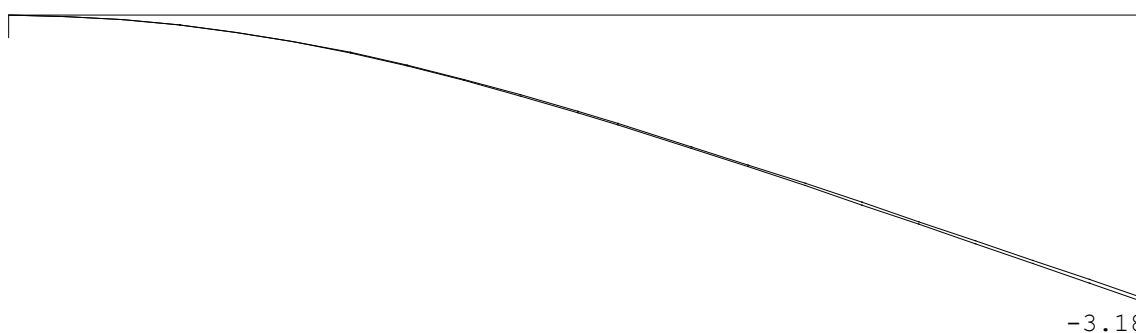

DOORBUIGINGEN wbij [mm]

Ligger:3 Karakteristieke combinatie

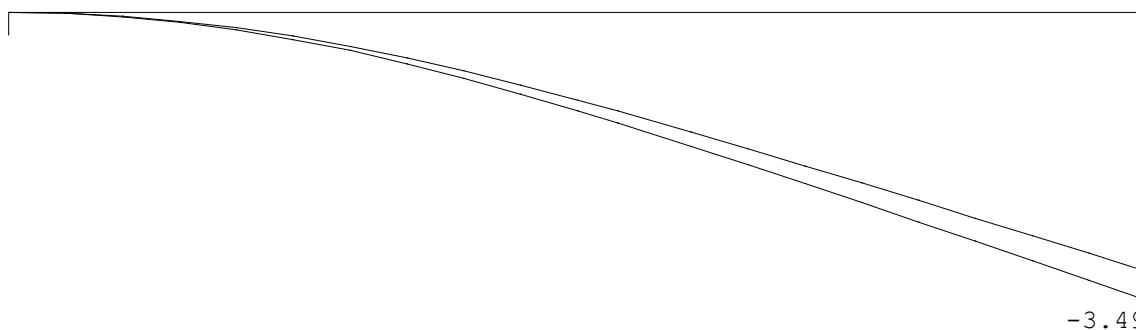

Project.....: 21038 - Herman Gorterstraat

Onderdeel....: Wand as 2

DOORBUIGINGEN Wmax [mm]

Ligger:3 Karakteristieke combinatie

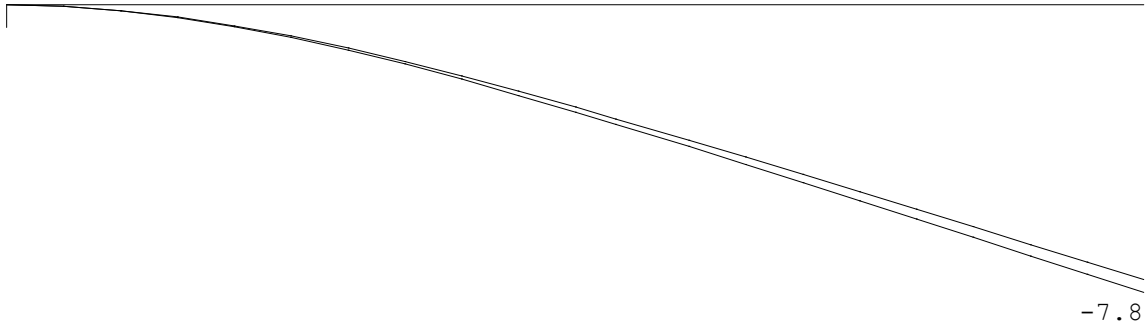

DOORBUIGINGEN

Karakteristieke combinatie

Veld	Zijde	positie	l_{rep}	w_1	w_2	-- w_{bij} --	w_{tot}	w_c	-- w_{max} --	
		[m]	[mm]	[mm]	[mm]	[mm] [lrep/]	[mm]	[mm]	[mm] [lrep/]	
1	Neg.	/	5600	-4.3	-3.2	-3.5	1606	-7.8	-7.8	721
1	Pos.	1.400	2800	0.4	0.5	0.5	5113	1.0	1.0	2816

DOORBUIGINGEN Wbij [mm]

Ligger:3 Frequente combinatie

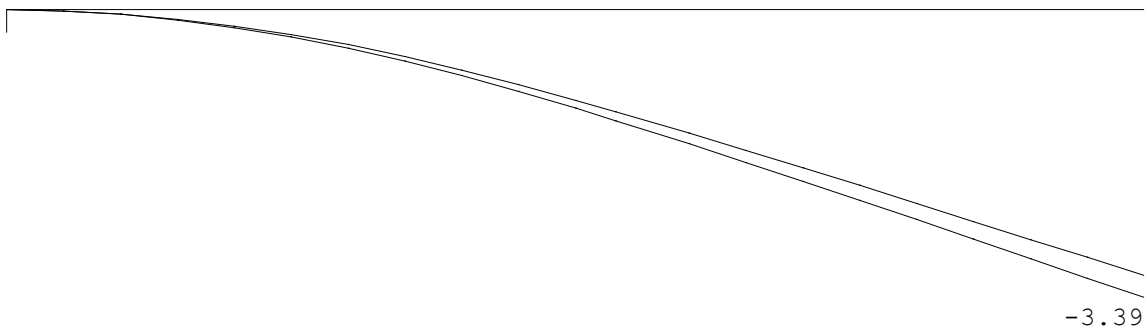

DOORBUIGINGEN Wmax [mm]

Ligger:3 Frequente combinatie

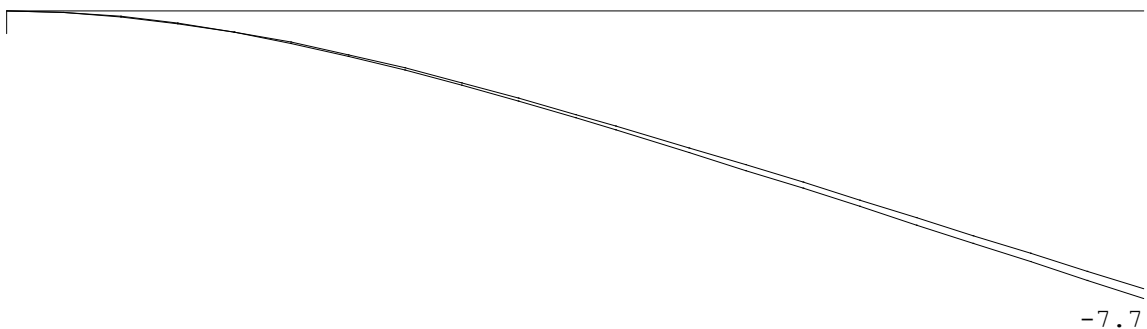

Project.....: 21038 - Herman Gorterstraat

Onderdeel....: Wand as 2

DOORBUIGINGEN

Frequente combinatie

Veld	Zijde	positie	l_{rep}	w_1	w_2	-- w_{bij} --		w_{tot}	w_c	-- w_{max} --	
		[m]	[mm]	[mm]	[mm]	[mm]	[lrep/]	[mm]	[mm]	[mm]	[lrep/]
1	Neg.	/	5600	-4.3	-3.2	-3.4	1650	-7.7		-7.7	729
1	Pos.	1.400	2800	0.4	0.5	0.5	5217	1.0		1.0	2847

DOORBUIGINGEN w_{bij}

[mm]

Ligger:3 Quasi-blijvende combinatie

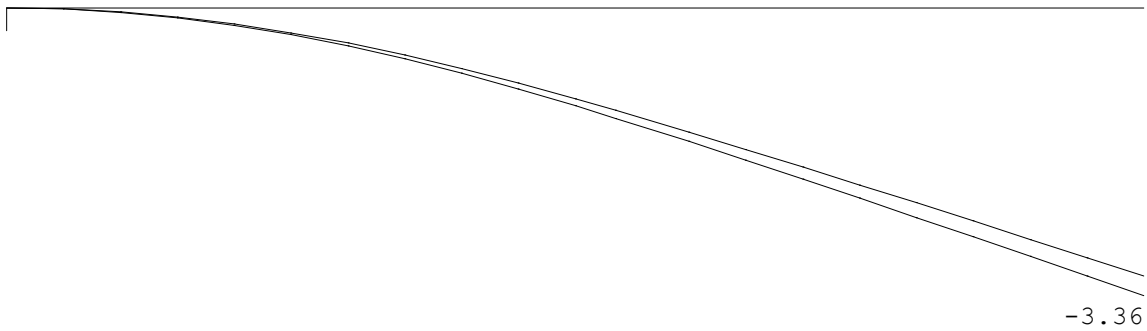

DOORBUIGINGEN w_{max}

[mm]

Ligger:3 Quasi-blijvende combinatie

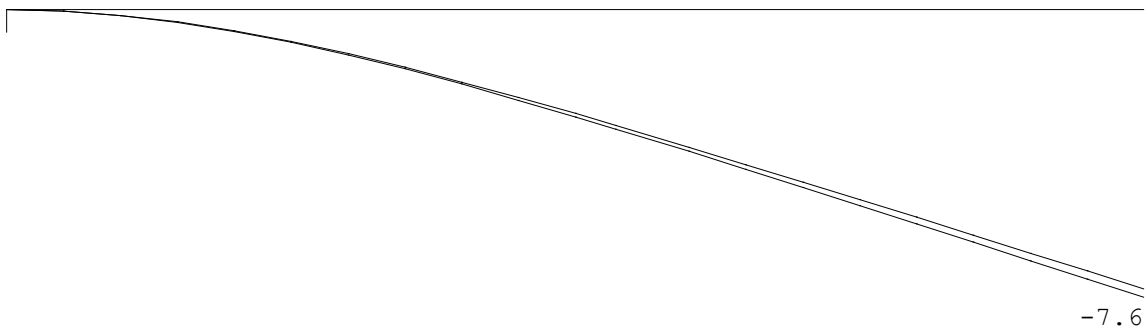

DOORBUIGINGEN

Quasi-blijvende combinatie

Veld	Zijde	positie	l_{rep}	w_1	w_2	-- w_{bij} --		w_{tot}	w_c	-- w_{max} --	
		[m]	[mm]	[mm]	[mm]	[mm]	[lrep/]	[mm]	[mm]	[mm]	[lrep/]
1	Neg.	/	5600	-4.3	-3.2	-3.4	1665	-7.6		-7.6	732
1	Pos.	1.400	2800	0.4	0.5	0.5	5253	1.0		1.0	2858

5.11

BIJLAGE 11 – KOLOM AS 4', KELDER, TUSSEN AS B-C

BIJ

LA

GE



Technosoft Kolomwapening release 6.71b

17 mei 2023

Project : Villa Herman Gorterstraat
 Onderdeel : as 4' tussen as B en C - kolom 250x300
 Dimensies : kN;m;rad (tenzij anders aangegeven)
 Datum : 15/05/2023
 Bestand : J:\Dropbox (BREEDID)\Projecten 2021\21038 - Herman
 Gorterstraat\BREED
 ID\Calculations\5_Werkfase\wapening wanden +
 keldervloer\As 4' tussen as B en C - kolom
 250x300.klw

Referentieperiode: 50

Toegepaste normen volgens Eurocode met Nederlandse NB

Beton	NEN-EN 1992-1-1:2011 (nl)	C2/A1:2015 (nl)	NB:2016 (nl)
	NEN-EN 1992-1-2:2005	C1:2008 (en)	NB:2011 (nl)

Geometrie

Type constructie : Kolom Rechthoekig Geschoord uit vlak (y-as)
 Kolomafmeting in X/Y (=b*h) [mm] : 300 * 250
 Kolomhoogte (L) [mm] : 3000
 Bij BRAND
 Kolomafmeting in X/Y (=b*h) [mm] : 280 * 230
 Kolomhoogte (L) [mm] : 3000
 Belastingenschema : Geschoord
 Kniklengtefactor X : 1.00
 Krommingsverdeling factor c X : 10.00

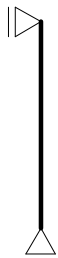

Belasting	BG1	BG2	BG3	Maatgevend BC
Omschrijving belastinggeval :				
Normaalkracht N Ek [kN] :	305.00	0.00	0.00	305.00
MEk,X boven [kNm] :	0.00	0.00	0.00	0.00
MEk,X onder [kNm] :	0.00	0.00	0.00	0.00
Belastingfactoren				
BC1 Fundamenteel :	1.00	1.00	1.00	Maatgevend X
BC2 Brand :	0.74	0.00	0.00	
Eis brandwerendheid in minuten :	30			

Project : Villa Herman Gorterstraat
 Onderdeel : as 4' tussen as B en C - kolom 250x300

Beton en Wapening

Betonkwaliteit	:	C30/37	Prefab	:	Nee
Soort spanningsrekdiagram	:	Parabolisch - rechthoekig diagram			
Staalsoort	:	B500A	Symm.wapening:	:	4-zijdig
f_{yk}	[N/mm ²]	500	ϵ_{uk}	[%]	2.5
Productiewijze	:	Koudgevormd			
Soort spanningsrekdiagram	:	Bi-lineair diagram met klimmende tak			
Basiswapening	[mm]	4 \emptyset 12	Bijlegw. [mm]	:	\emptyset 12, 16
Beugels	[mm]	\emptyset 8			

Betondekking

Milieu	:	XC3
Gestort tegen bestaand beton	:	Nee
Element met plaatgeometrie	:	Nee
Specifieke kwaliteitsbeheersing	:	Nee
Oneffen beton oppervlak	:	Nee
Ondergrond	:	Glad / N.v.t.
Constructieklasse	:	S4
Grootste korrel	:	31.5

Hoofdwapening	:	2de laag
Nominale dekking	:	30
Toegepaste dekking	:	38
Gelijkwaardige diameter	:	16
$C_{min,b}$ $C_{min,dur}$ ΔC_{dur}	:	16 25 0
C_{min} ΔC_{dev} C_{nom}	:	25 5 30

Beugel / Verdeelwapening	:	1ste laag
Nominale dekking	:	30
Toegepaste dekking	:	30
Gelijkwaardige diameter	:	8
$C_{min,b}$ $C_{min,dur}$ ΔC_{dur}	:	8 25 0
C_{min} ΔC_{dev} C_{nom}	:	25 5 30

Project : Villa Herman Gorterstraat
 Onderdeel : as 4' tussen as B en C - kolom 250x300

Maatgevende belastingcombinatie 1: (Fundamenteel)

Berekende gegevens	X-as	Y-as	BC1
Berekend moment $M_{Ed,ber}$ [kNm] :	13.09		
Min. wapening art. 9.5.2(2) [mm ²] :	150.0		
Min. wap. art. 9.5.2(2)&(4) [mm ²] :	201.1 = 4 ø8.0		
Min. wap. trekzone 7.3.2 [mm ²] :	0.0		
Totaal ber. wap. 1e/2e orde [mm ²] :	0.0		
Maatgevende wapening [mm ²] :	201.1		

Gevonden wapening	basiswapening	X-as	Y-as
Bijlegcombinatie 1	452 [mm ²] :	4 ø12.0	
Bijlegcombinatie 2	452 [mm ²] :	4 ø12.0	

Grafische uitvoer bijlegcombinatie 1

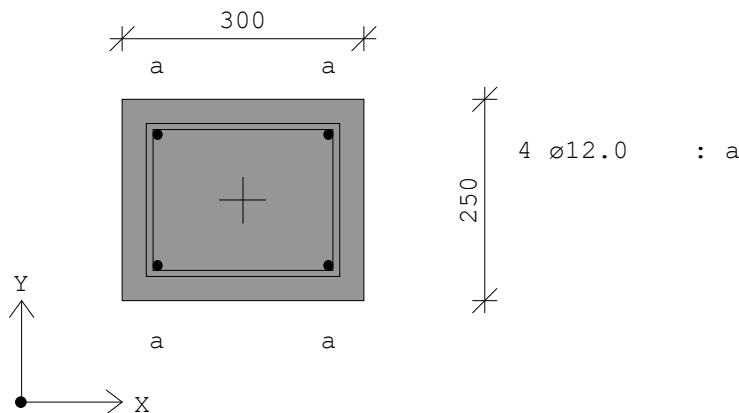

Grafische uitvoer bijlegcombinatie 2

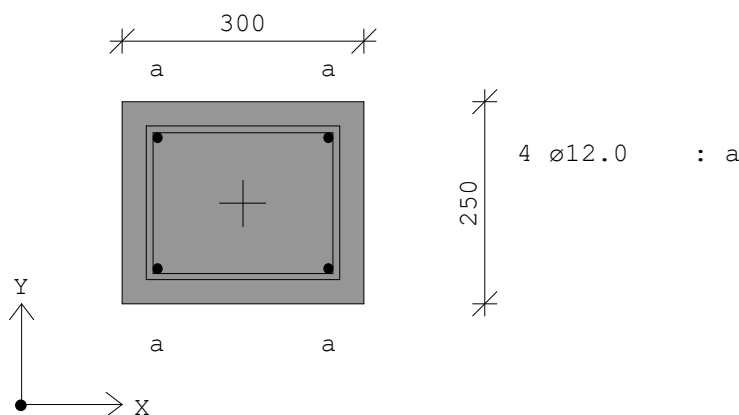

Technosoft Kolomwapening release 6.71b

17 mei 2023

Project : Villa Herman Gorterstraat
Onderdeel : as 4' tussen as B en C - kolom 250x300

Opmerkingen

[10] * = Minimum wapening X-ri (bel.comb. 1,2).

[101] De berekende wapening is de totale wapening in de doorsnede.

[111] Alzijdige wapening vier-zijdig symmetrisch (bel.comb. 1)

[108] Gevonden wapening onverminderd toepassen over gehele kolomhoogte
(bel.comb. 1)

5.12

BIJLAGE 12 – PRINCIPE WANDWAPENING TS KOLOMWAPENING

BIJ

LA

GE



Project : Herman Gorterstraat
 Onderdeel : Principe verticale wandwapening
 Dimensies : kN;m;rad (tenzij anders aangegeven)
 Datum : 15/05/2023
 Bestand : J:\Dropbox (BREEDID)\Projecten 2021\21038 - Herman
 Gorterstraat\BREED
 ID\Calculations\5_Werkfase\wapening wanden +
 keldervloer\20230515_Principe verticale
 wandwapening.klw

Referentieperiode: 50

Toegepaste normen volgens Eurocode met Nederlandse NB

Beton	NEN-EN 1992-1-1:2011 (nl)	C2/A1:2015 (nl)	NB:2016 (nl)
	NEN-EN 1992-1-2:2005	C1:2008 (en)	NB:2011 (nl)

Geometrie

Type constructie	:	Wand
Wandbreedte	[mm] :	1000
Wanddikte in buigingsricht.	[mm] :	250
Wandhoogte (L)	[mm] :	3400
Bij BRAND		
Wandbreedte	[mm] :	1000
Wanddikte in buigingsricht.	[mm] :	240
Wandhoogte (L)	[mm] :	3400
Belastingsschema	:	Geschoord
Kniklengtefactor X	:	1.00
Krommingsverdeling factor c X	:	10.00



Belasting

	BG1	BG2	BG3	Maatgevend BC	
Omschrijving belastinggeval	:				
Normaalkracht N Ek	[kN] :	800.00	40.00	0.00	40.00
MEk,X boven	[kNm] :	35.00	35.00	0.00	35.00
MEk,X onder	[kNm] :	0.00	0.00	0.00	0.00
Belastingfactoren					
BC1	Fundamenteel :	1.00	0.00	0.00	
BC2	Brand :	0.75	0.00	0.00	
BC3	Fundamenteel :	0.00	1.00	0.00	Maatgevend X
BC4	Brand :	0.00	0.75	0.00	
Eis brandwerendheid in minuten	:	30			

Project : Herman Gorterstraat
 Onderdeel : Principe verticale wandwapening

Beton en Wapening

Betonkwaliteit	: C30/37	Prefab	: Nee
Soort spanningsrekdiagram	: Parabolisch - rechthoekig diagram		
Staalsoort	: B500A	Symm.wapening:	: 2-zijdig
f_{yk} [N/mm ²]	: 500	ϵ_{uk} [%]	: 2.5
Productiewijze	: Koudgevormd		
Soort spanningsrekdiagram	: Bi-lineair diagram met klimmende tak		
Basiswapening [mm]	: $\emptyset 8.0$ hoh 150	Bijlegw. [mm]	: $\emptyset 10.0, 12.0$
Hoofdwapening in laag	: 1	Verdeelw. [mm]	: $\emptyset 8.0$

Betondekking

Milieu	:	XC1
Gestort tegen bestaand beton	:	Nee
Element met plaatgeometrie	:	Nee
Specifieke kwaliteitsbeheersing	:	Nee
Oneffen beton oppervlak	:	Nee
Ondergrond	:	Glad / N.v.t.
Constructieklasse	:	S3
Grootste korrel	:	31.5

Hoofdwapening	:	1ste laag
Nominale dekking	:	17
Toegepaste dekking	:	25
Gelijkwaardige diameter	:	12
$C_{min,b}$ $C_{min,dur}$ ΔC_{dur}	:	12 10 0
C_{min} ΔC_{dev} C_{nom}	:	12 5 17
Beugel / Verdeelwapening	:	2de laag
Nominale dekking	:	15
Toegepaste dekking	:	37
Gelijkwaardige diameter	:	8
$C_{min,b}$ $C_{min,dur}$ ΔC_{dur}	:	8 10 0
C_{min} ΔC_{dev} C_{nom}	:	10 5 15

Project : Herman Gorterstraat
Onderdeel : Principe verticale wandwapening

Belastingcombinatie 1: (Fundamenteel)

Berekende gegevens	X-as	BC1
Berekend moment $M_{Ed,ber}$ [kNm] :	39.53	
Min. wap. art. 9.6.2(1) [mm ² /m] :	0.0	
Min.wap. art. 9.6.2(1)&(3) [mm ² /m]:	98.2 =2x(ø5.0 hoh 400)	
Min. wap. trekzone 7.3.2 [mm ² /m] :	0.0	
Tot. ber. wap. 1e/2e orde [mm ² /m] :	0.0	
Maatgevende wapening [mm ² /m] :	98.2	

Project : Herman Gorterstraat
Onderdeel : Principe verticale wandwapening

Belastingcombinatie 2: (Brand)

Berekende gegevens	X-as	BC2
Berekend moment $M_{Ed,ber}$ [kNm] :	29.65	
Min. wap. art. 9.6.2(1) [mm ² /m] :	0.0	
Min.wap. art. 9.6.2(1)&(3) [mm ² /m] :	98.2 =2x(ø5.0 hoh 400)	
Tot. ber. wap. 1e/2e orde [mm ² /m] :	0.0	
Maatgevende wapening [mm ² /m] :	98.2	

Project : Herman Gorterstraat
Onderdeel : Principe verticale wandwapening

Belastingcombinatie 3: (Fundamenteel)

Berekende gegevens	X-as	BC3
Berekend moment $M_{Ed,ber}$ [kNm] :	35.23	
Min. wap. art. 9.6.2(1) [mm ² /m] :	0.0	
Min.wap. art. 9.6.2(1)&(3) [mm ² /m]:	98.2 =2x(ø5.0 hoh 400)	
Min. wap. trekzone 7.3.2 [mm ² /m] :	0.0	
Tot. ber. wap. 1e/2e orde [mm ² /m] :	595.2	
Maatgevende wapening [mm ² /m] :	595.2	

Project : Herman Gorterstraat
Onderdeel : Principe verticale wandwapening

Belastingcombinatie 4: (Brand)

Berekende gegevens	X-as	BC4
Berekend moment $M_{Ed,ber}$ [kNm] :	26.42	
Min. wap. art. 9.6.2(1) [mm ² /m] :	0.0	
Min.wap. art. 9.6.2(1) & (3) [mm ² /m] :	98.2 =2x(ø5.0 hoh 400)	
Tot. ber. wap. 1e/2e orde [mm ² /m] :	420.5	
Maatgevende wapening [mm ² /m] :	420.5	

Project : Herman Gorterstraat
Onderdeel : Principe verticale wandwapening

Maatgevende belastingcombinatie 3: (Fundamenteel)

Gevonden wapening basiswapening extra staven

Bijlegcombinatie 1 670 [mm²/m] : 2x(ø8.0 hoh 150)

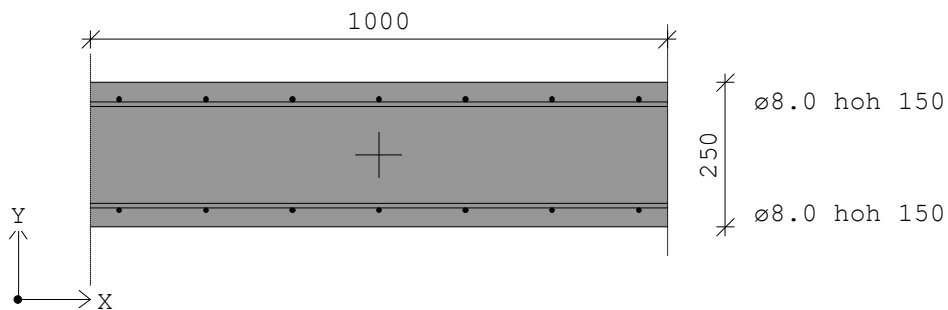
Grafische uitvoer bijlegcombinatie 1**Opmerkingen**

[10] * = Minimum wapening X-ri (bel.comb. 1,2) .

[101] De berekende wapening is de totale wapening in de doorsnede.

[113] Twee-zijdige wapening (bel.comb. 3,1,2,4)

5.13

BIJLAGE 13 – KELDERVLOER PONSHECK

BIJ

LA

GE



Datum : 15/05/2023
 Eenheden : kN/m/rad
 Bestand : C:\Users\5.1, 2, e\Dropbox (BREEDID)\Projecten
 2021\2103 - Herman Gorterstraat\BREED
 ID\Calculations\5_Werkfase\Bestaande
 palen\20230627_Afschuiving vloerstrook kelder as
 3'.cnw

Toegepaste normen volgens Eurocode met Nederlandse NB

Belastingen	NEN-EN 1990:2002	C2:2010,A1:2019	NB:2019(nl)
	NEN-EN 1991-1-1:2002	C1/C11:2019	NB:2019(nl)
Beton	NEN-EN 1992-1-1:2011(nl)	C2/A1:2015(nl)	NB:2016(nl)

Pons. (B)

GEOMETRIE

Kolomvorm : Rond
 Vorm omtrek : Cirkelvormig
 Kolomsoort : Rand - onder de vloer - art. 6.4.4 (1) (6.47)
 Betonkwaliteit : C30/37
 Nuttige hoogte d [mm]: 250

Kolom

Breedte lastvlak c [mm]: 240
 Randafstand a1 [mm]: 155

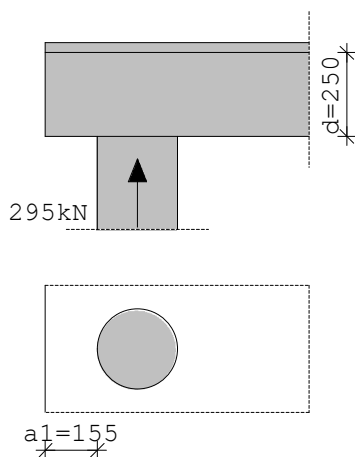

WAPENING

Staalkwaliteit	: B500A	Wapeningsratio ρ_{1z}	: 0.01000
Wapeningsratio ρ_{1y}	: 0.01000	Tangentiele afstand s_t [mm]	: 375
Radiale afstand s_r [mm]	: 187	Hoek α	: 90
Beugel diameter [mm]	: 8		

BELASTING

Kracht V_{Ed} [kN]: 295.0

Datum : 15/05/2023

Eenheden : kN/m/rad

RESULTATEN

Ponsomtrek	$v_{Rd,c}$	$v_{Rd,max}$	v_{Ed}	$v_{Rd,s}$	A_{sw}/s_r	A_{sw}	code
[mm]	[N/mm ²]	[N/mm ²]	[N/mm ²]	[N/mm ²]	[mm ² /mm]	[mm ²]	
u_0	565	n.v.t.	4.22	2.92	n.v.t.	n.v.t.	n.v.t.
u_1	2498	0.71	4.22	0.66	0.00	0.00	0 [42]

Opmerkingen[42] Er is geen ponswapening nodig ($v_{Ed} < v_{Rd,c}$).**Controle-omtrek u_0 (565 mm)**

Rekenwaarde schuifspanning volgens art. 6.4.5 (formule 6.53)

Nuttige plaatdikte d [mm]: 250 Omtrek u_0 [mm]: 565Factor β : 1.40Schuifsp. v_{Ed} [N/mm²]: 2.92 Schuifsp. $v_{Rd,max}$ [N/mm²]: 4.22**Controle-omtrek u_1 (2498 mm)**

Vorm omtrek : Cirkelvormig

Rekenwaarde schuifspanning volgens art. 6.4

Afstand tot aan kolom[mm]: 500

Nuttige plaatdikte d [mm]: 250 Omtrek u_1 [mm]: 2498Factor β : 1.40Schuifsp. v_{Ed} [N/mm²]: 0.66Schuifsp. $v_{Rd,c}$ [N/mm²]: 0.71